

NOTES:

- MATERIALS:
 - HOUSING:
 - "BLANK"=NYLON 6/6, UNFILLED UL94 V-2, COLOR: NATURAL
 - "130"=GLASS FILLED LCP, UL94 V-0, COLOR: BLACK
 - IEC 60335-1, 5TH EDITION GLOW WIRE CAPABLE
 - "210"=NYLON 6/6, UNFILLED UL94 V-0, COLOR: NATURAL
 - "400"=NYLON 6/6, UNFILLED UL94 V-0, COLOR: BLACK
 - TERMINALS:
 - BRASS
- TERMINAL PLATING:
 - "BLANK"=.000035/(0.00090) MIN. REFLOWED MATTE TIN OVER .000020/(0.00050) MIN. COPPER (PREPLATE) (FINISH IS BRIGHT IN APPEARANCE, THICKNESS AS APPLIED PRIOR TO REFLOW)
 - GS2=.000015/(0.00038) MIN. SELECT GOLD AND .000100/(0.00254) MIN. SELECT MATTE TIN OVER .000050/(0.00127) MIN. NICKEL OVERALL
 - GS=.000030/(0.00076) MIN. SELECT GOLD AND .000100/(0.00254) MIN. SELECT MATTE TIN OVER .000050/(0.00127) MIN. NICKEL OVERALL
 - S=.000100/(0.00254) MIN. BRIGHT TIN OVER .000050/(0.00127) MIN. NICKEL
 - MS=.000100/(0.00254) MIN. MATTE TIN OVER .000050/(0.00127) MIN. NICKEL
- PRODUCT SPECIFICATION: PS-5556-001
- PACKAGING: TRAY PACKED PER PK-5556-002
- PART MATES WITH MINI-FIT JR. RECEPTACLE NO. 5557.
- ALL DIMENSIONS ARE REFERENCE UNLESS OTHERWISE SPECIFIED.
- PART IS NOT DESIGNED FOR CURRENT SHARING.
- PARTS ARE NOT TO BE MATED OR UN-MATED WHILE CIRCUITS ARE LIVE.
- PART CONFORMS TO CLASS "B" REQUIREMENTS OF COSMETIC SPECIFICATION PS-45499-002.

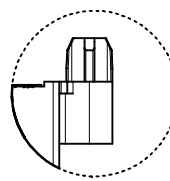

PRESS FIT PEG OPTION

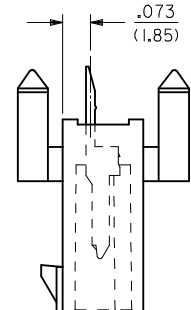
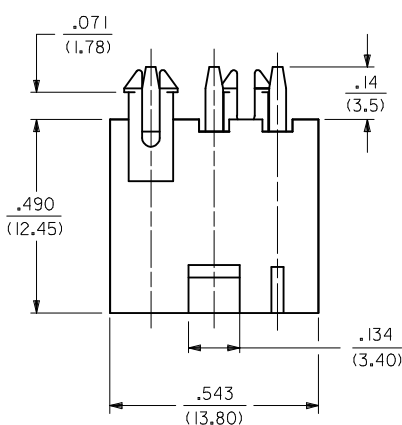
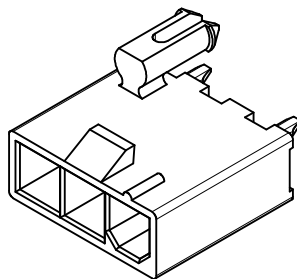
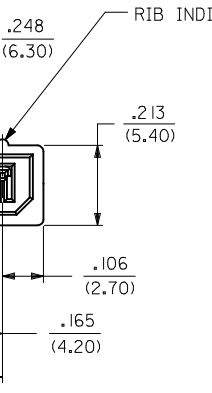
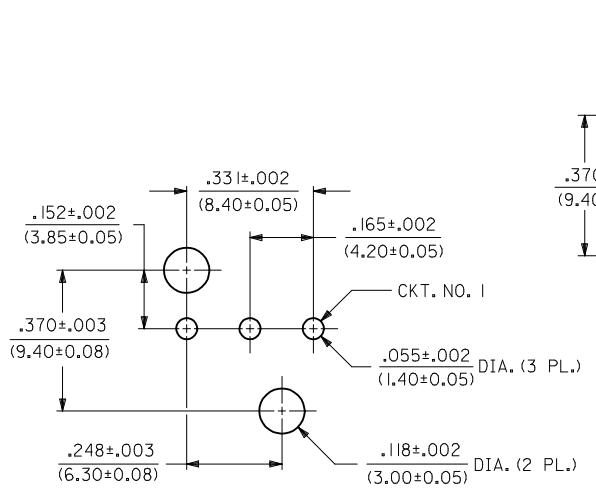

PART NO.	ENG. NO.	HOUSING MAT'L. (SEE NOTE 1)	PLATING (SEE NOTE 2)
39-30-1039	5566-03A3	"BLANK"	"BLANK"
39-30-2033	↑ -03A3GS2	↑	GS2
39-30-2031	-03A3GS	↓	GS
39-30-5037	-03A3S	↓	S
46999-0792	-03A3MS	"BLANK"	MS
46999-0680	-03A15GS-130	130	GS
46999-0685	-03A15MS-130	130	MS
39-30-2030	-03A3-210	210	"BLANK"
39-30-2034	-03A3GS2-210	↑	GS2
39-30-2032	-03A3GS-210	↓	GS
39-30-5038	-03A3S-210	↓	S
46999-0793	↓ -03A3MS-210	210	MS
46999-0563	5566-03A3MS-400	400	MS

LEGEND

5566-03A3*-***

BASE NO. _____

CIRCUIT SIZE _____

MOUNTING _____
 3 = SNAP FIT PEGS
 15 = PRESS FIT PEGS

PLATING _____
 (SEE NOTE 2)

HOUSING MATERIAL _____
 (SEE NOTE 1)

CORRECT PEG (G-9) EC NO: UCP2017-0370 DRAWN:CSLAFTER 2016/08/12 CHKD:JBELL 2016/08/12 APPR:FSMITH 2016/09/21	QUALITY SYMBOLS ▽=0 ▽=0 ▽=0	GENERAL TOLERANCES (UNLESS SPECIFIED)		DIMENSION STYLE IN/MM		SCALE 4:1	DESIGN UNITS METRIC	THIRD ANGLE PROJECTION	
		mm	INCH	DRAWN BY GEP	DATE 1990/06/07	MINI-FIT JR. VERT. HDR. ASSY. W/PEGS (SINGLE ROW)			
L5	REV	4 PLACES	± ---	± ---	CHECKED BY RJF	DATE 1990/06/07	DOCUMENT NO. SDA-5566-03*3*		
		3 PLACES	± ---	± .010	DATE 2012/09/05	SHEET NO. 1 OF 1			
		2 PLACES	± 0.25	± .020	APPROVED BY FSMITH		THIS DRAWING CONTAINS INFORMATION THAT IS PROPRIETARY TO MOLEX INCORPORATED AND SHOULD NOT BE USED WITHOUT WRITTEN PERMISSION		
		1 PLACE	± 0.50	± ---					
		0 PLACE	± ---	± ---					
		ANGULAR ±1/2°		SEE CHART					
		DRAFT WHERE APPLICABLE MUST REMAIN WITHIN DIMENSIONS		SIZE C					

RECOMMENDED HOLE LAYOUT FOR .070/(1.78) MAX. THICK P. C. BOARD