

13 12 11 10 9 8 7 6 5 4 3 2 1

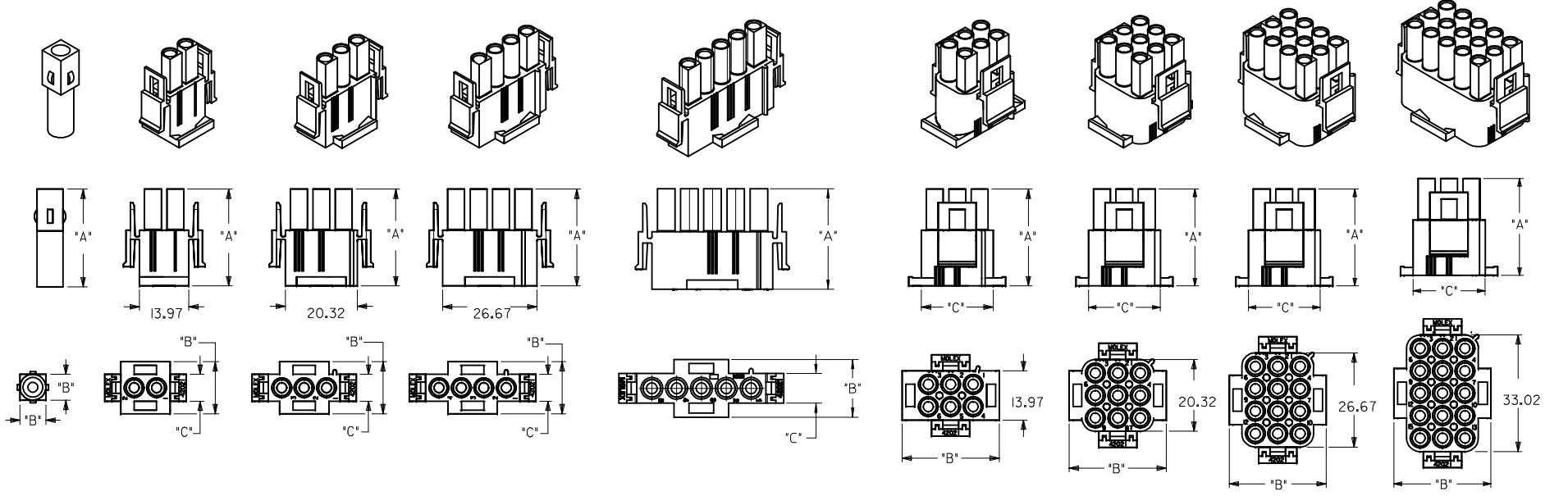

E
D
C
B
A

12 11 10 9 8 7 6 5 4 3 2 1

GENERAL TOL REVISED EC NO: 12016-0086 DRW:SS06 CHKD: APPR: SHMARG 2016/05/10 2016/05/11	QUALITY SYMBOLS ∇=0 ∇=0 ∇=0	GENERAL TOLERANCES (UNLESS SPECIFIED)		DIMENSION STYLE MM ONLY		SCALE 1:1	DESIGN UNITS METRIC	THIRD ANGLE PROJECTION	
		4 PLACES ± --- ± ---	mm INCH	DRAWN BY MRAMAKRI SHNA	DATE 2013/01/30	TITLE HOUSING, PLUG 2.13 DIA. SERIES			
		3 PLACES ± --- ± ---		CHECKED BY	DATE	APPROVED BY KPRASAD DATE 2013/03/11			
		2 PLACES ± 0.25 ± ---							
1 PLACE ± 0.36 ± ---		ANGULAR ± --- °		MATERIAL NO. SEE SHEET 2	DOCUMENT NO. SD-36643-009	SHEET NO. 1 OF 2			
0 PLACE ± --- ± ---		DRAFT WHERE APPLICABLE MUST REMAIN WITHIN DIMENSIONS		THIS DRAWING CONTAINS INFORMATION THAT IS PROPRIETARY TO MOLEX INCORPORATED AND SHOULD NOT BE USED WITHOUT WRITTEN PERMISSION					

13	12	11	10	9	8	7	6	5	4	3	2	1
PART NO.	CIRCUIT SIZE	MATERIAL (SEE NOTE 1)	DIM. "A"	DIM. "B"	DIM. "C"							
366430001	1	E	27.69	7.37	----							
366430002	2	E	27.61	14.73	7.62							
366430003	3	E	27.61	14.73	7.62							
366430004	4	E	27.61	14.73	7.62							
366430010	5	E	27.61	14.73	7.62							
366430005	6	E	27.61	27.43	20.32							
366430006	9	E	27.61	27.43	20.32							
366430007	12	E	27.61	27.43	20.32							
366430008	15	E	27.61	27.43	20.32							

NOTES:

- MATERIAL CODE
"E"= NYLON 94V-2
COLOUR : NATURAL
GLOW WIRE COMPATIBLE WITH CTI OF 325 VOLTS, ACCORDING TO IEC 60335-4TH EDITION
- UNLESS OTHERWISE INDICATED, DIMENSIONS ARE FOR REFERENCE ONLY
- PLUG HOUSINGS MATE WITH:
 - CAP HOUSINGS, 2.13 DIA.SERIES 36644(SD-36644-009)
 - HEADER ASSEMBLY, 2.13 DIA. SERIES 36757(SD-36757-0002)
- HOUSING DESIGNED TO BE USED WITH TERMINALS:
 - PINS, 2.13 DIA. SERIES 42023
 - SOCKETS, 2.13 DIA. SERIES 42024
- CONTACTS ARE ON 6.35 GRID CENTERLINE SPACING
- PRODUCT SPECIFICATION PS-42022-0001 APPLIES

GENERAL TOL REVISED EC NO: 12016-0086 DRWN:SS06 CHKD: APPR: SHMARG 2016/05/10 2016/05/11	QUALITY SYMBOLS	GENERAL TOLERANCES (UNLESS SPECIFIED)	DIMENSION STYLE MM ONLY	SCALE 1:1	DESIGN UNITS METRIC	THIRD ANGLE PROJECTION
	▽=0	4 PLACES ± --- ± ---	mm INCH	DRAWN BY MRAMAKRISHNA	DATE 2013/01/30	TITLE HOUSING, PLUG 2.13 DIA. SERIES
	▽=0	3 PLACES ± --- ± ---		CHECKED BY	DATE	
	▽=0	2 PLACES ± 0.25 ± ---		APPROVED BY KPRASAD	DATE 2013/03/11	
		1 PLACE ± 0.36 ± ---		MATERIAL NO.	DOCUMENT NO.	SHEET NO. 2 OF 2
		0 PLACE ± --- ± ---		SEE TABLE		SD-36643-009
		ANGULAR ± ---°		THIS DRAWING CONTAINS INFORMATION THAT IS PROPRIETARY TO MOLEX INCORPORATED AND SHOULD NOT BE USED WITHOUT WRITTEN PERMISSION		
		DRAFT WHERE APPLICABLE MUST REMAIN WITHIN DIMENSIONS				