

# PS9513, PS9513L1, PS9513L2, PS9513L3

1 Mbps, OPEN COLLECTOR OUTPUT, FOR GATE DRIVE INTERFACE  
 INTELLIGENT POWER MODULE  
 8 mm CREEPAGE 8-PIN DIP HIGH-SPEED PHOTOCOUPLER

R08DS0126EJ0201  
 Rev.2.01  
 Aug 03, 2017

## DESCRIPTION

The PS9513, PS9513L1, PS9513L2 and PS9513L3 are optically coupled isolators containing a GaAlAs LED on the input side and a photo diode and a signal processing circuit on the output side on one chip.

The PS9513 is designed specifically for high common mode transient immunity (CMR) and low pulse width distortion with operating temperature. It is suitable for IPM drive.

The PS9513L1 is lead bending type for long creepage distance.

The PS9513L2 is lead bending type for long creepage distance (Gull-wing) for surface mount.

The PS9513L3 is lead bending type (Gull-wing) for surface mounting.

## FEATURES

- Long creepage distance (8 mm MIN. : PS9513L1, PS9513L2)
- High common mode transient immunity ( $CM_H, CM_L = \pm 15 \text{ kV}/\mu\text{s MIN}$ )
- High-speed response ( $t_{PHL} = 500 \text{ ns MAX.}, t_{PLH} = 750 \text{ ns MAX.}$ )
- Maximum propagation delays ( $t_{PLH} - t_{PHL} = 270 \text{ ns TYP.}$ )
- Pulse width distortion ( $|t_{PHL} - t_{PLH}| = 270 \text{ ns TYP.}$ )
- Open collector output
- Ordering number of tape product : PS9513L2-E3 : 1 000 pcs/reel  
 : PS9513L3-E3 : 1 000 pcs/reel
- Pb-Free product
- Safety standards
  - UL approved: UL1577, Double protection
  - CSA approved: CA5A, CAN/CSA-C22.2 No. 60065, CAN/CSA-C22.2 No.60950-1, Reinforced insulation
  - BSI approved: BS EN 62368-1, Reinforced insulation
  - SEMKO approved: EN 62368-1, IEC 62368-1, Reinforced insulation
  - NEMKO approved: EN 62368-1, Reinforced insulation
  - DEMKO approved: EN 62368-1, Reinforced insulation
  - FIMKO approved: EN 62368-1, Reinforced insulation
  - VDE approved: DIN EN 60747-5-5 (Option)

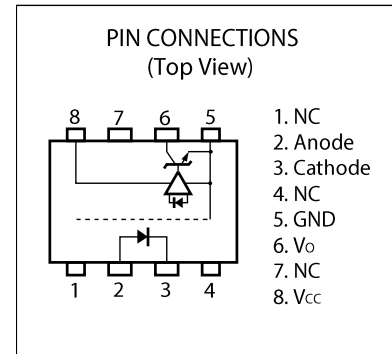

## APPLICATIONS

- IPM Driver
- General purpose inverter

Start of mass production  
 2006-06

**PACKAGE DIMENSIONS (UNIT: mm)**

DIP Type

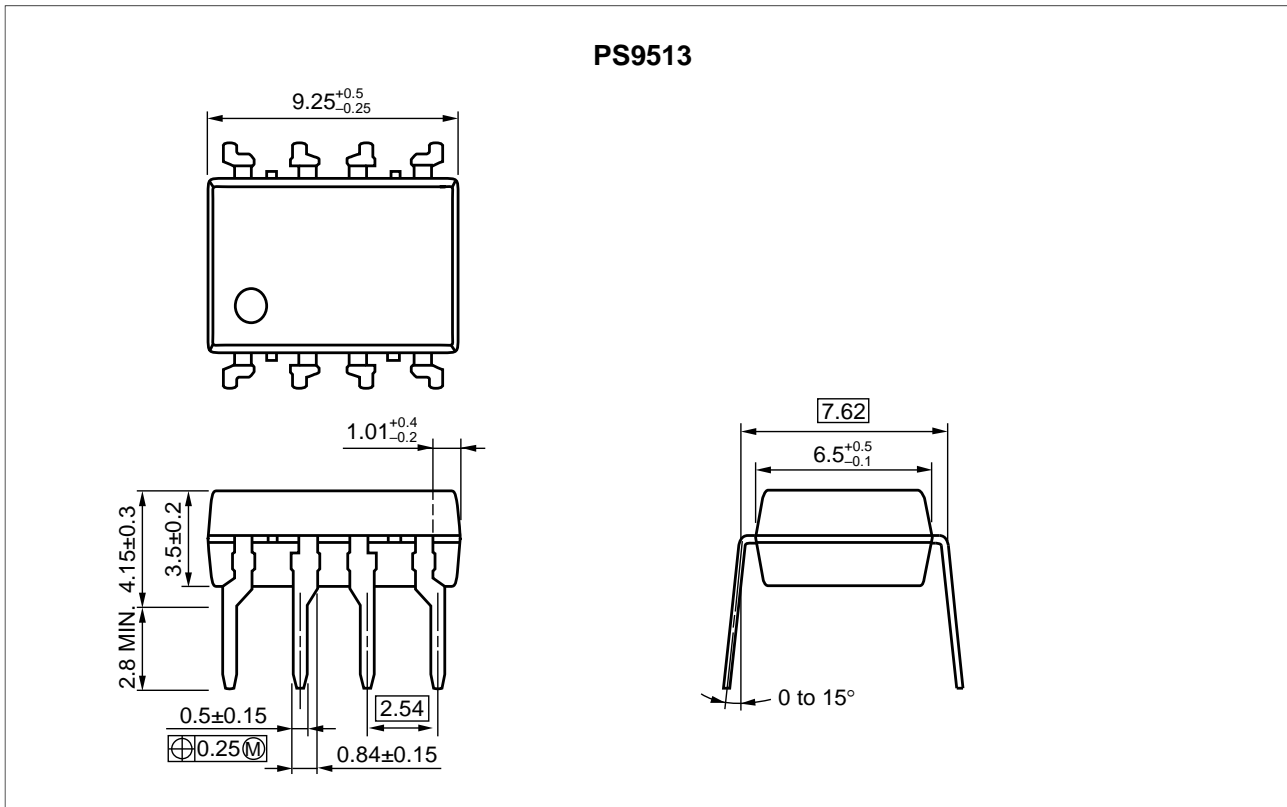

Weight: 0.55g (typ.)

Lead Bending Type (Gull-wing) For Surface Mount

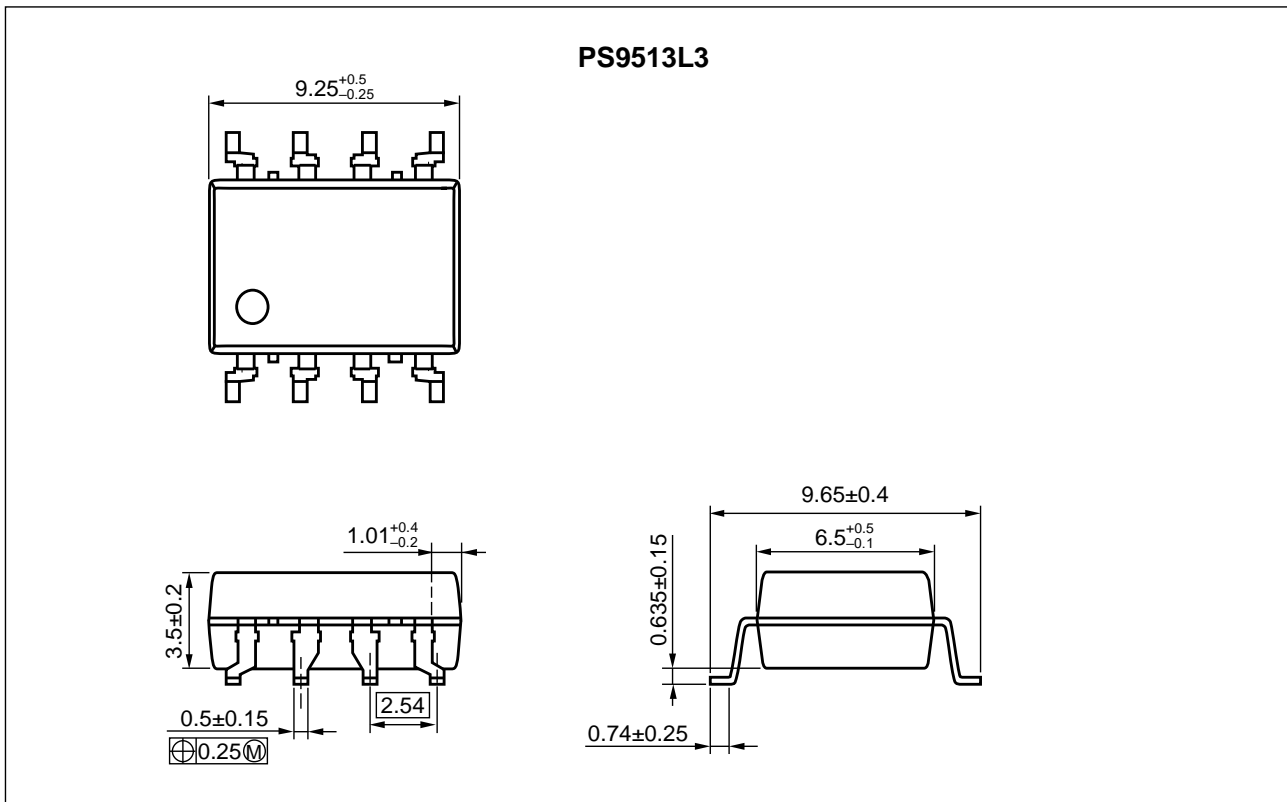

Lead Bending Type For Long Creepage Distance

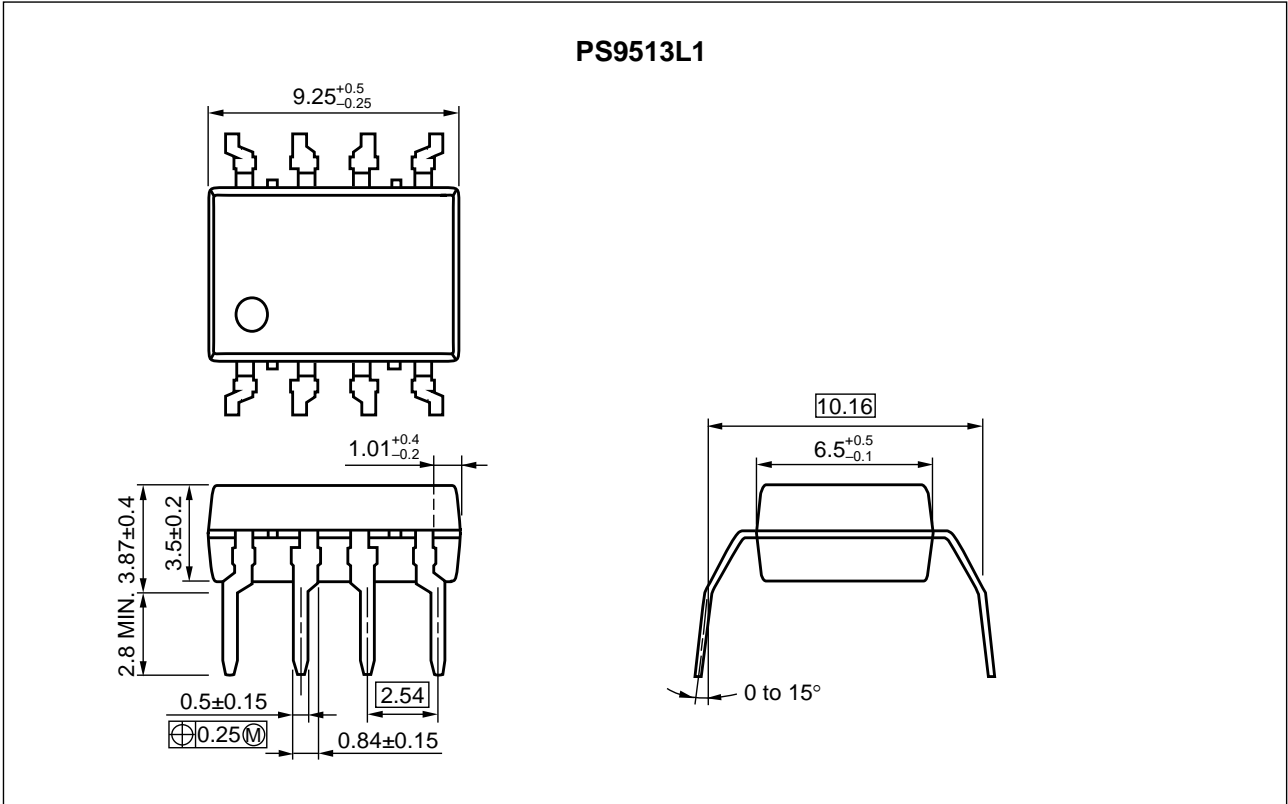

Lead Bending Type For Long Creepage Distance (Gull-wing) For Surface Mount

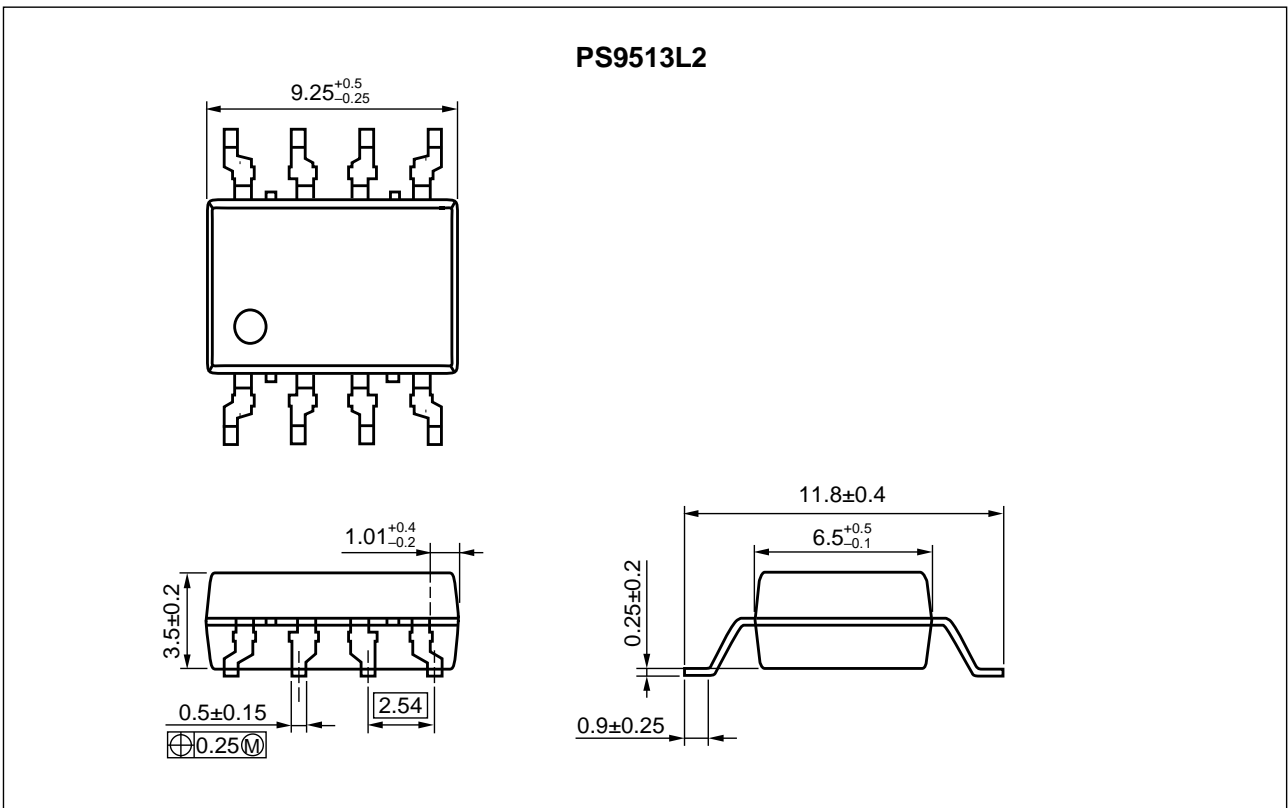

### PHOTOCOUPLER CONSTRUCTION

Parameter	PS9513, PS9513L3	PS9513L1, PS9513L2
Air Distance (MIN.)	7 mm	8 mm
Creepage Distance (MIN.)	7 mm	8 mm
Isolation Distance (MIN.)	0.4 mm	0.4 mm

### FUNCTIONAL DIAGRAM

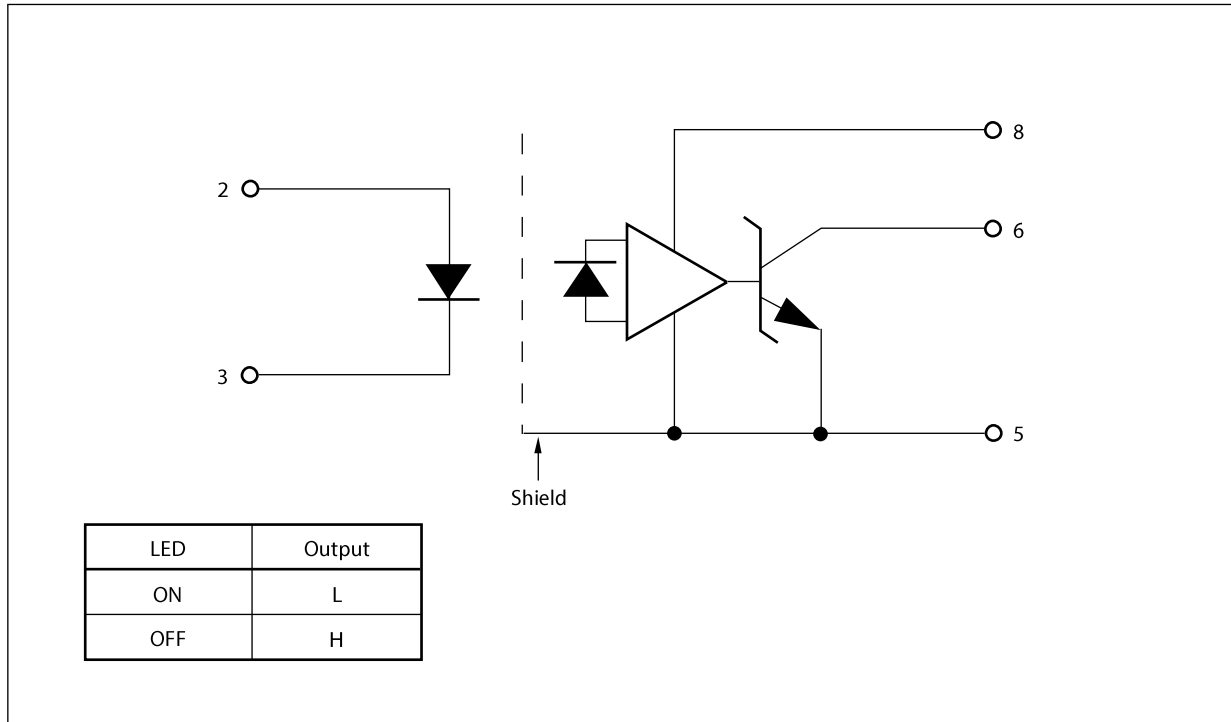

### MARKING EXAMPLE

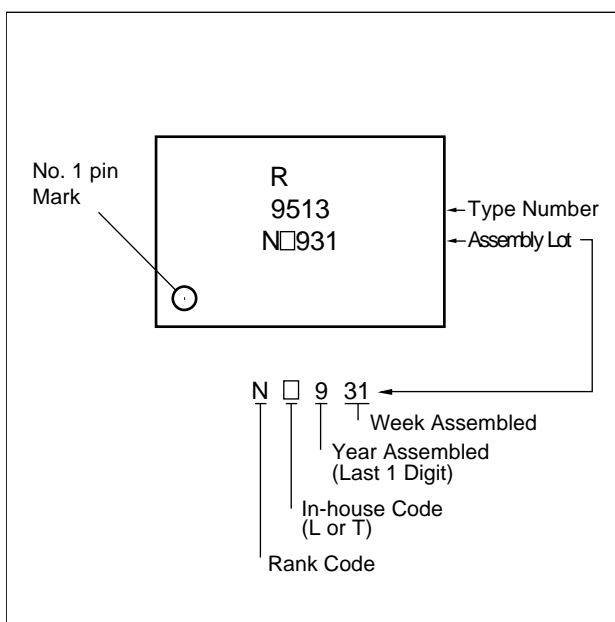

**ORDERING INFORMATION**

Part Number	Order Number	Solder Plating Specification	Packing Style	Safety Standard Approval	Application Part Number*1
PS9513	PS9513-AX	Pb-Free (Ni/Pd/Au)	Magazine case 50 pcs	Standard products (UL, CSA, BSI, SEMKO, NEMKO, DEMKO, FIMKO approved)	PS9513
PS9513L1	PS9513L1-AX				PS9513L1
PS9513L2	PS9513L2-AX				PS9513L2
PS9513L3	PS9513L3-AX				PS9513L3
PS9513L2-E3	PS9513L2-E3-AX		Embossed Tape 1 000 pcs/reel		PS9513L2
PS9513L3-E3	PS9513L3-E3-AX		Embossed Tape 1 000 pcs/reel		PS9513L3
PS9513-V	PS9513-V-AX		Magazine case 50 pcs	UL, CSA , BSI, SEMKO, NEMKO, DEMKO, FIMKO approved	PS9513
PS9513L1-V	PS9513L1-V-AX				PS9513L1
PS9513L2-V	PS9513L2-V-AX				PS9513L2
PS9513L3-V	PS9513L3-V-AX			DIN EN 60747-5-5 Approved (Option)	PS9513L3
PS9513L2-V-E3	PS9513L2-V-E3-AX				PS9513L2
PS9513L3-V-E3	PS9513L3-V-E3-AX				PS9513L3

Notes\*: 1. For the application of the Safety Standard, following part number should be used.

**ABSOLUTE MAXIMUM RATINGS (T<sub>A</sub> = 25°C, unless otherwise specified)**

Parameter		Symbol	Ratings	Unit
Diode	Forward Current *1	I <sub>F</sub>	25	mA
	Reverse Voltage	V <sub>R</sub>	5.0	V
Detector	Supply Voltage	V <sub>CC</sub>	-0.5 to +25	V
	Output Voltage	V <sub>O</sub>	-0.5 to +25	V
	Output Current	I <sub>O</sub>	15	mA
	Power Dissipation *2	P <sub>C</sub>	100	mW
Isolation Voltage *3		BV	5 000	Vr.m.s.
Operating Ambient Temperature		T <sub>A</sub>	-40 to +100	°C
Storage Temperature		T <sub>stg</sub>	-55 to +125	°C

Notes\*: 1. Reduced to 0.33 mA/°C at T<sub>A</sub> = 70°C or more.

2. Reduced to 2.0 mW/°C at T<sub>A</sub> = 70°C or more.

3. AC voltage for 1 minute at T<sub>A</sub> = 25°C, RH = 60% between input and output.

Pins 1-4 shorted together, 5-8 shorted together.

**RECOMMENDED OPERATING CONDITIONS**

Parameter	Symbol	MIN.	TYP.	MAX.	Unit
Forward Current	I <sub>F</sub>	10		20	mA
Output Voltage	V <sub>O</sub>	0		20	V
Supply Voltage	V <sub>CC</sub>	4.5	15	20	V
Input Voltage	V <sub>F</sub>	0		0.8	V

**ELECTRICAL CHARACTERISTICS** ( $T_A = -40$  to  $+100^\circ\text{C}$ ,  $V_{CC} = 15$  V, unless otherwise specified)

Parameter		Symbol	Conditions	MIN.	TYP.*1	MAX.	Unit
Diode	Forward Voltage	$V_F$	$I_F = 10$ mA	1.3	1.65	2.1	V
	Reverse Current	$I_R$	$V_R = 3$ V			200	$\mu\text{A}$
	Terminal Capacitance	$C_t$	$V = 0$ V, $f = 1$ MHz, $T_A = 25^\circ\text{C}$		30		pF
Detector	Low Level Output Voltage	$V_{OL}$	$I_F = 10$ mA, $I_{OL} = 2.4$ mA		0.13	0.6	V
	High Level Output Current	$I_{OH}$	$V_{CC} = 20$ V, $V_F = 0.8$ V		1.0	50	$\mu\text{A}$
	High Level Supply Current	$I_{CCH}$	$V_{CC} = 20$ V, $V_F = 0.8$ V, $V_O = \text{open}$		0.6	1.3	mA
	Low Level Supply Current	$I_{CCL}$	$V_{CC} = 20$ V, $I_F = 10$ mA, $V_O = \text{open}$		0.6	1.3	mA
Coupled	Threshold Input Current (H $\rightarrow$ L)	$I_{FHL}$	$V_O = 0.8$ V, $I_O = 0.75$ mA		0.86	5.0	mA
	Current Transfer Ratio ( $I_C/I_F$ )	CTR	$I_F = 10$ mA, $V_O = 0.6$ V	44	110		%
	Isolation Resistance	$R_{I-O}$	$V_{I-O} = 1$ kV <sub>DC</sub> , RH = 40 to 60%, $T_A = 25^\circ\text{C}$	$10^{11}$			$\Omega$
	Isolation Capacitance	$C_{I-O}$	$V = 0$ V, $f = 1$ MHz, $T_A = 25^\circ\text{C}$		0.7		pF
	Propagation Delay Time (H $\rightarrow$ L)*2	$t_{PHL}$	$I_F = 10$ mA, $R_L = 20$ k $\Omega$ , $C_L = 100$ pF, $V_{THHL} = 1.5$ V, $V_{THLH} = 2.0$ V		250	500	ns
	Propagation Delay Time (L $\rightarrow$ H)*2	$t_{PLH}$			520	750	
	Maximum Propagation Delays	$t_{PLH}-t_{PHL}$		-200	270	650	
	Pulse Width Distortion (PWD)*2	$ t_{PHL}-t_{PLH} $			270	650	
	Common Mode Transient Immunity at High Level Output*3	$CM_H$		$T_A = 25^\circ\text{C}$ , $I_F = 0$ mA, $V_O > 3.0$ V, $V_{CM} = 1.5$ kV, $R_L = 20$ k $\Omega$ , $C_L = 100$ pF	15		
Common Mode Transient Immunity at Low Level Output*3	$CM_L$	$T_A = 25^\circ\text{C}$ , $I_F = 10$ mA, $V_O < 1.0$ V, $V_{CM} = 1.5$ kV, $R_L = 20$ k $\Omega$ , $C_L = 100$ pF	15			kV/ $\mu\text{s}$	

- Notes\*: 1. Typical values at  $T_A = 25^\circ\text{C}$ .  
 2. Test circuit for propagation delay time

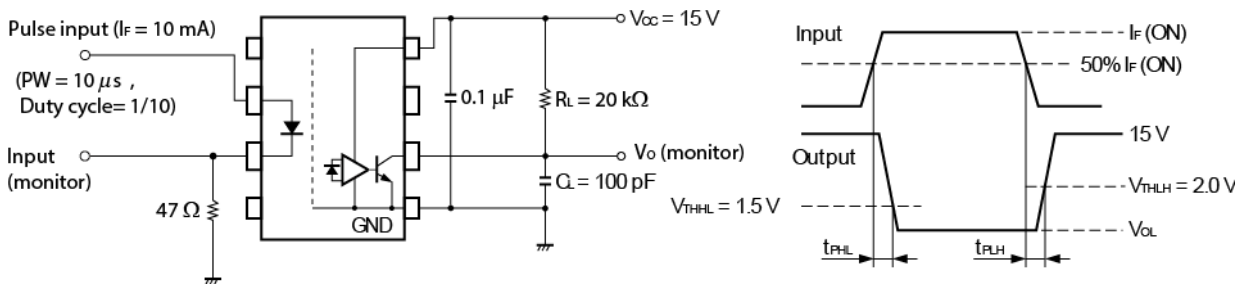

**Remark**  $C_L$  includes probe and stray wiring capacitance.

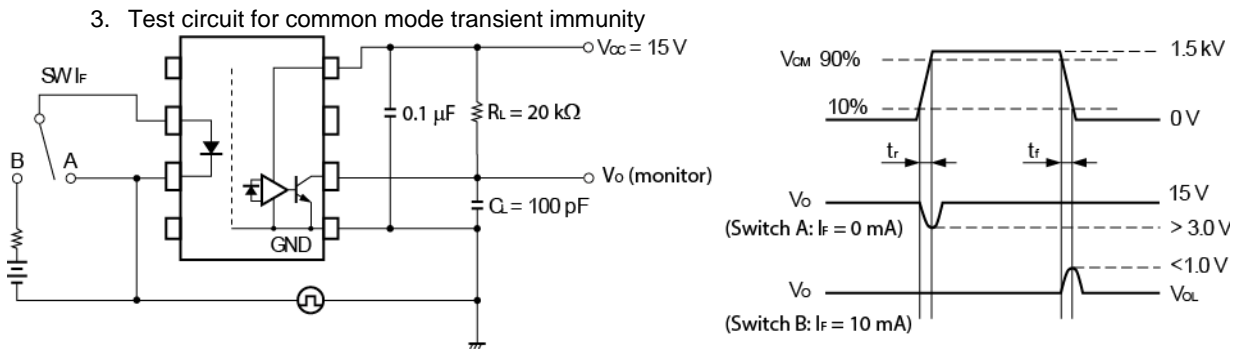

**Remark**  $C_L$  includes probe and stray wiring capacitance.

## USAGE CAUTIONS

1. This product is weak for static electricity by designed with high-speed integrated circuit so protect against static electricity when handling.
2. By-pass capacitor of more than  $0.1 \mu\text{F}$  is used between  $V_{CC}$  and GND near device. Also, ensure that the distance between the leads of the photocoupler and capacitor is no more than 10 mm.
3. Pins 1, 4 (which is an NC<sup>\*1</sup> pin) can either be connected directly to the GND pin on the LED side or left open. Also, Pin 7 (which is an NC<sup>\*1</sup> pin) can either be connected directly to the GND pin on the detector side or left open.  
 Unconnected pins should not be used as a bypass for signals or for any other similar purpose because this may degrade the internal noise environment of the device.  
<sup>\*1</sup> NC: Non-Connection (No Connection)
4. Avoid storage at a high temperature and high humidity.



**TYPICAL CHARACTERISTICS (T<sub>A</sub> = 25°C unless otherwise specified)**

SUPPLY CURRENT vs. AMBIENT TEMPERATURE

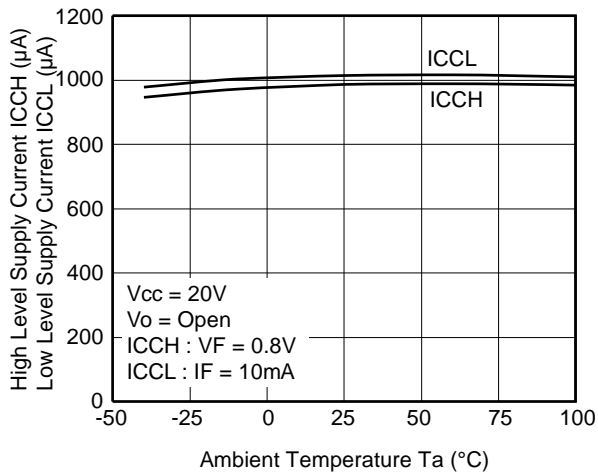

THRESHOLD INPUT CURRENT vs. AMBIENT TEMPERATURE

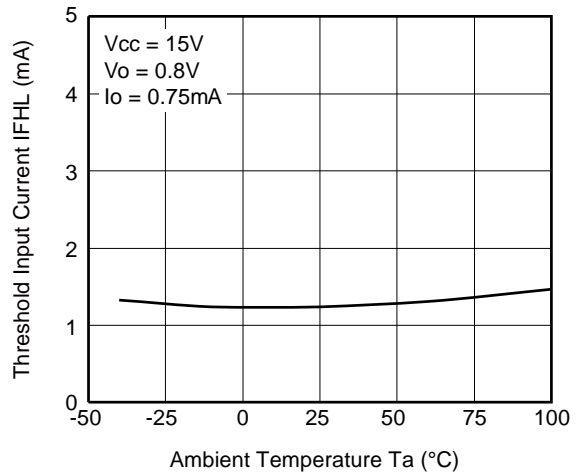

LOW LEVEL OUTPUT VOLTAGE vs. AMBIENT TEMPERATURE

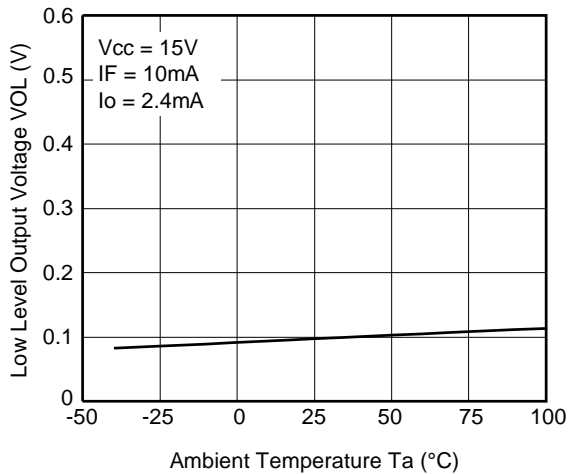

OUTPUT CURRENT vs. FORWARD CURRENT

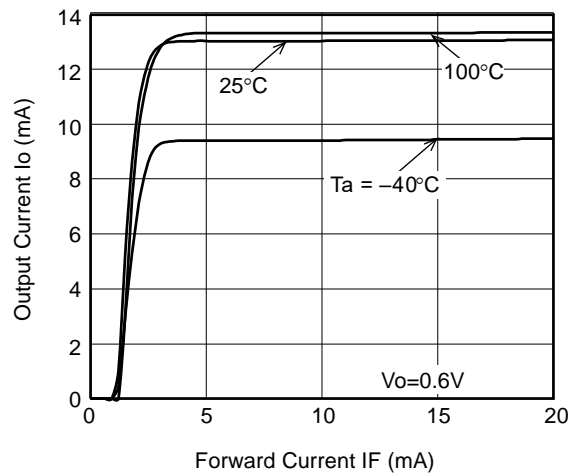

OUTPUT CURRENT vs. AMBIENT TEMPERATURE

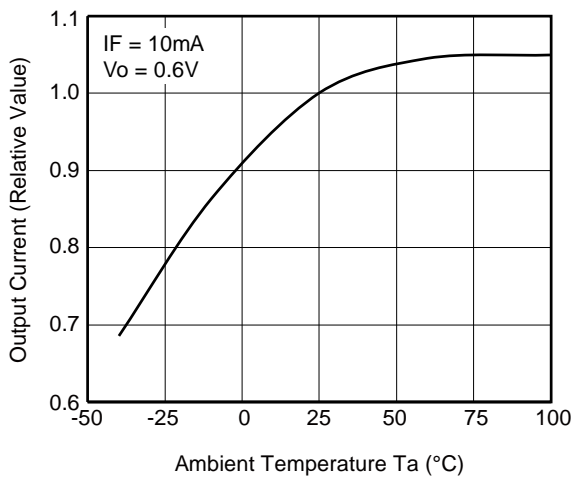

PROPAGATION DELAY TIME, MAXIMUM PROPAGATION DELAYS vs. FORWARD CURRENT

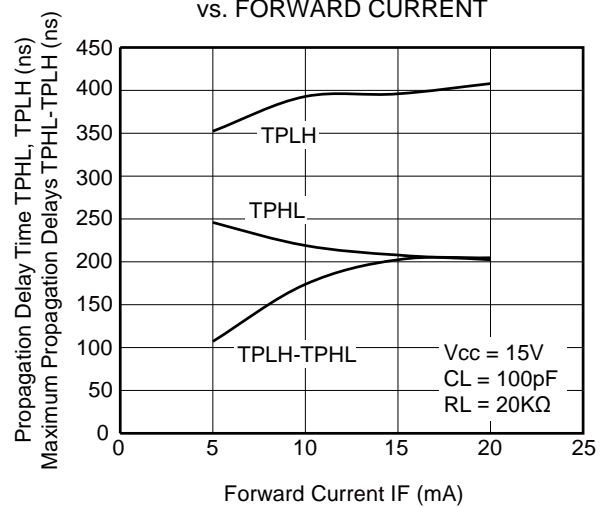

PROPAGATION DELAY TIME,  
MAXIMUM PROPAGATION DELAYS  
vs. SUPPLY VOLTAGE

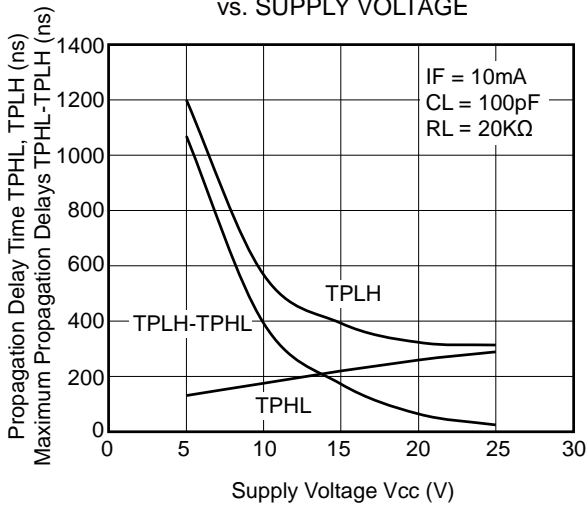

PROPAGATION DELAY TIME,  
PULSE WIDTH DISTORTION  
vs. AMBIENT TEMPERATURE

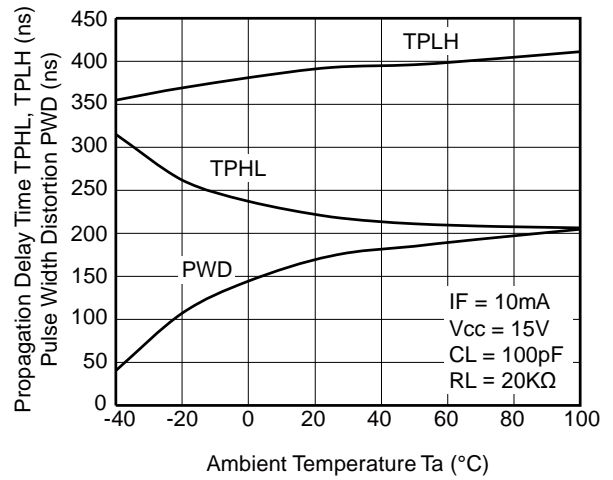

PROPAGATION DELAY TIME  
vs. LOAD CAPACITANCE

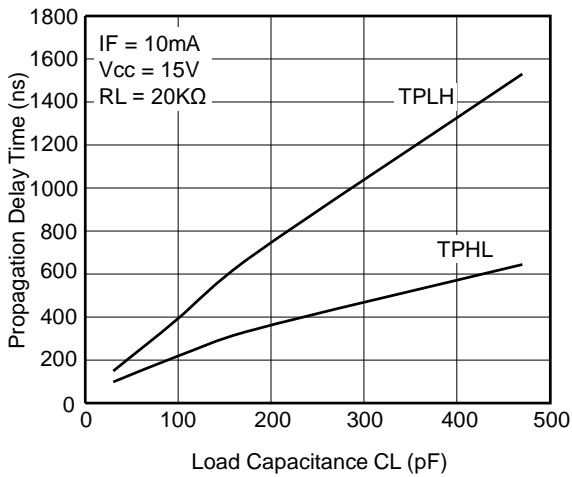

PROPAGATION DELAY TIME,  
MAXIMUM PROPAGATION DELAYS  
vs. LOAD RESISTANCE

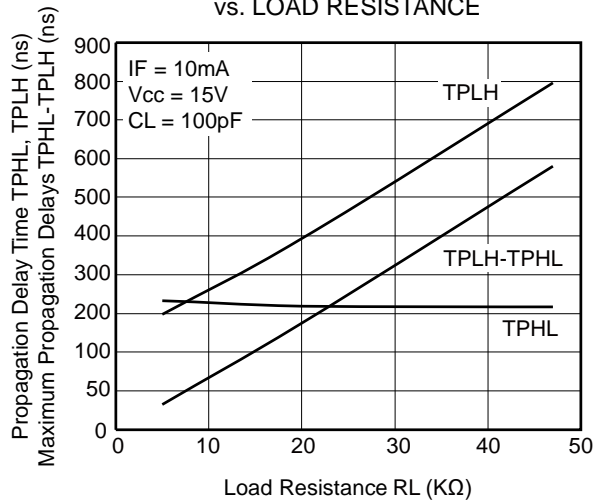

PROPAGATION DELAY TIME,  
MAXIMUM PROPAGATION DELAYS  
vs. LOAD RESISTANCE

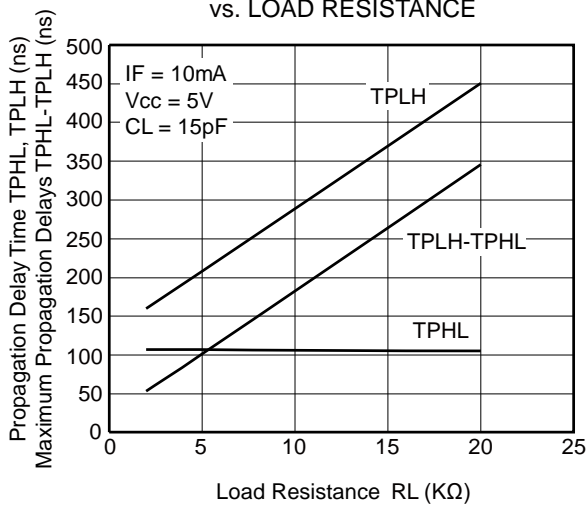

**TAPING SPECIFICATIONS (UNIT: mm)**

**Outline and Dimensions (Tape)**

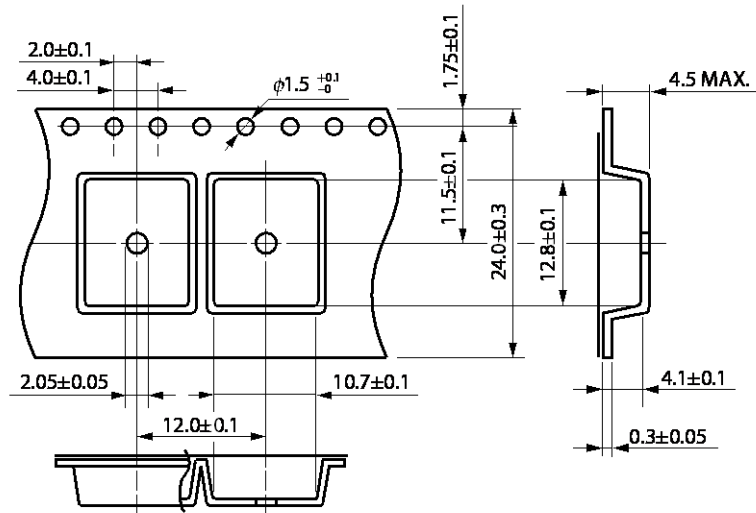

**Tape Direction**

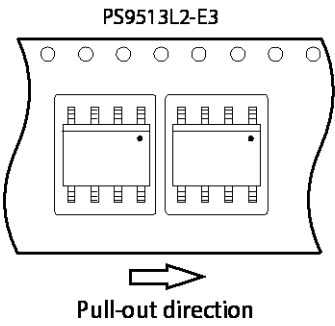

**Outline and Dimensions (Reel)**

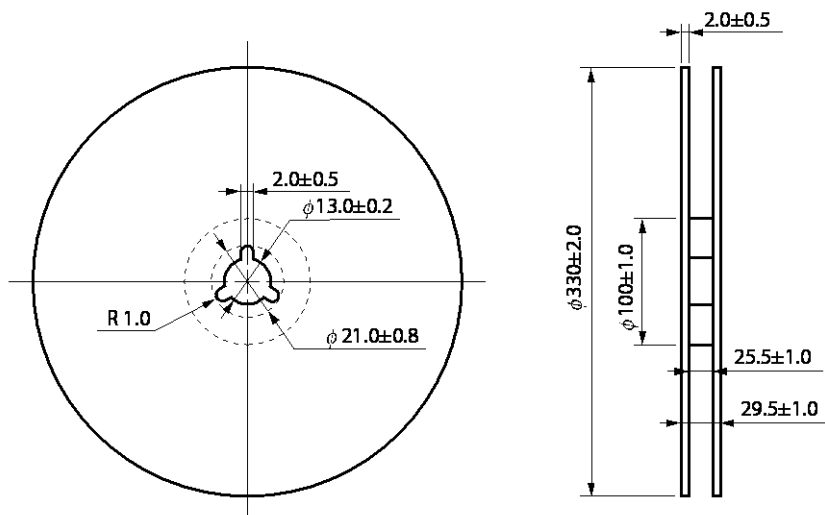

Packing: 1 000 pcs/reel

Outline and Dimensions (Tape)

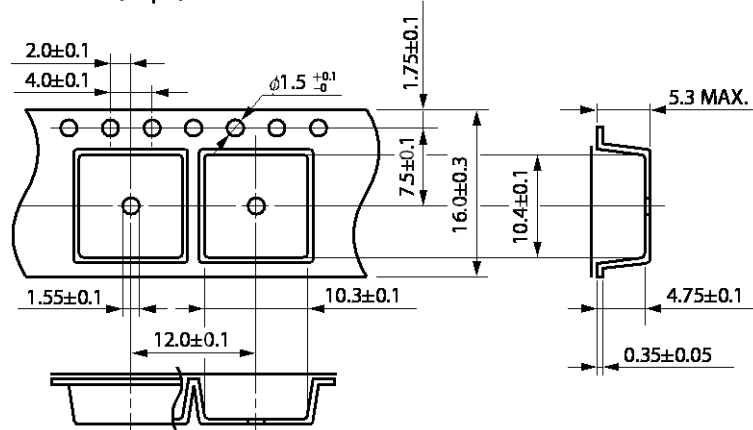

Tape Direction

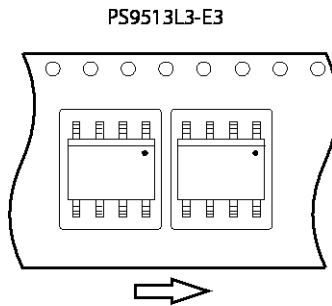

Outline and Dimensions (Reel)

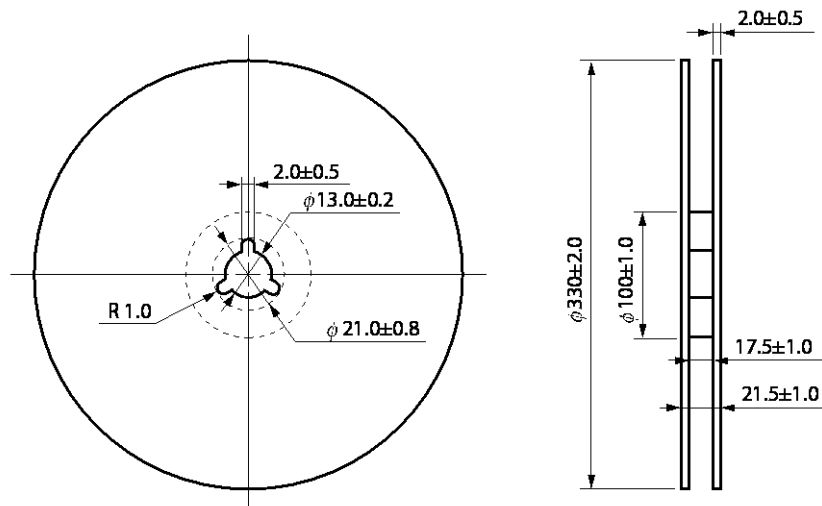

Packing: 1 000 pcs/reel

**RECOMMENDED MOUNT PAD DIMENSIONS (UNIT: mm)**

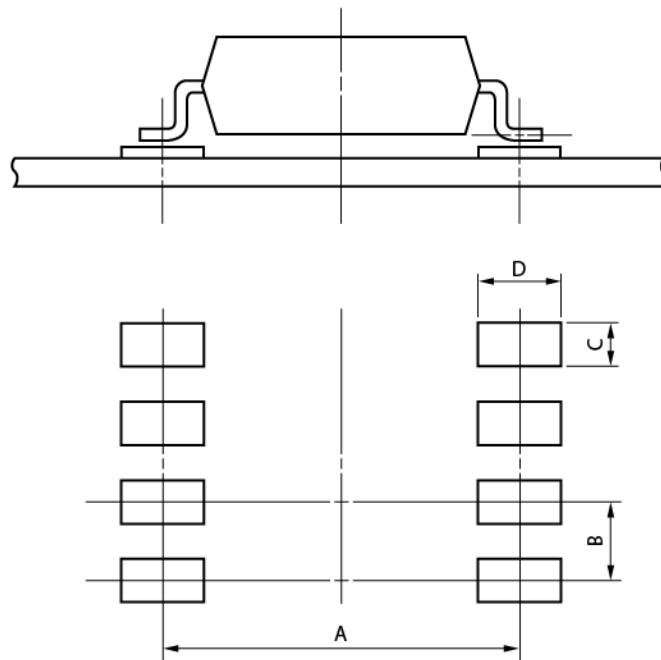

Part Number	Lead Bending	A	B	C	D
PS9513L2	lead bending type (Gull-wing) for long creepage distance (surface mount)	10.2	2.54	1.7	2.2
PS9513L3	lead bending type (Gull-wing) for surface mount	8.2	2.54	1.7	2.2

## NOTES ON HANDLING

### 1. Recommended soldering conditions

#### (1) Infrared reflow soldering

- Peak reflow temperature 260°C or below (package surface temperature)
- Time of peak reflow temperature 10 seconds or less
- Time of temperature higher than 220°C 60 seconds or less
- Time to preheat temperature from 120 to 180°C 120±30 s
- Number of reflows Three
- Flux Rosin flux containing small amount of chlorine (The flux with a maximum chlorine content of 0.2 Wt% is recommended.)

Recommended Temperature Profile of Infrared Reflow

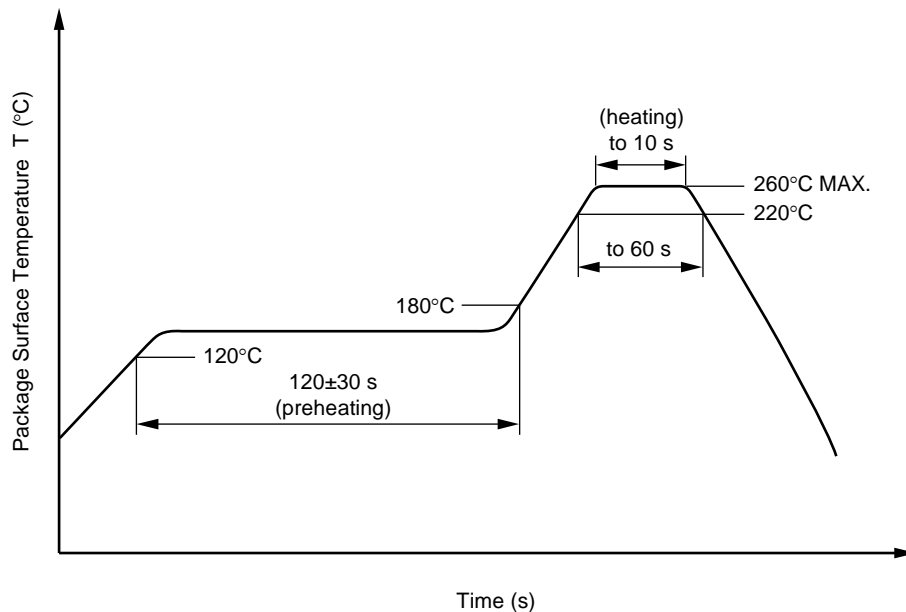

#### (2) Wave soldering

- Temperature 260°C or below (molten solder temperature)
- Time 10 seconds or less
- Preheating conditions 120°C or below (package surface temperature)
- Number of times One (Allowed to be dipped in solder including plastic mold portion.)
- Flux Rosin flux containing small amount of chlorine (The flux with a maximum chlorine content of 0.2 Wt% is recommended.)

#### (3) Soldering by Soldering Iron

- Peak Temperature (lead part temperature) 350°C or below
- Time (each pins) 3 seconds or less
- Flux Rosin flux containing small amount of chlorine (The flux with a maximum chlorine content of 0.2 Wt% is recommended.)

(a) Soldering of leads should be made at the point 1.5 to 2.0 mm from the root of the lead

(b) Please be sure that the temperature of the package would not be heated over 100°C

#### (4) Cautions

- Fluxes  
Avoid removing the residual flux with freon-based and chlorine-based cleaning solvent.

### 2. Cautions regarding noise

Be aware that when voltage is applied suddenly between the photocoupler's input and output or between V<sub>CC</sub>-GND at startup, the output transistor may enter the on state, even if the voltage is within the absolute maximum ratings.

**SPECIFICATION OF VDE MARKS LICENSE DOCUMENT**

Parameter	Symbol	Speck	Unit
Climatic test class (IEC 60068-1/DIN EN 60068-1)		40/100/21	
Dielectric strength maximum operating isolation voltage	$U_{IORM}$	1 130	$V_{peak}$
Test voltage (partial discharge test, procedure a for type test and random test) $U_{pr} = 1.6 \times U_{IORM}, P_d < 5 \text{ pC}$	$U_{pr}$	1 808	$V_{peak}$
Test voltage (partial discharge test, procedure b for all devices) $U_{pr} = 1.875 \times U_{IORM}, P_d < 5 \text{ pC}$	$U_{pr}$	2 119	$V_{peak}$
Highest permissible overvoltage	$U_{TR}$	8 000	$V_{peak}$
Degree of pollution (DIN EN 60664-1 VDE 0110 Part 1)		2	
Comparative tracking index (IEC 60112/DIN EN 60112 (VDE 0303 Part 11))	CTI	175	
Material group (DIN EN 60664-1 VDE 0110 Part 1)		III a	
Storage temperature range	$T_{stg}$	-55 to +125	°C
Operating temperature range	$T_A$	-40 to +100	°C
Isolation resistance, minimum value $V_{IO} = 500 \text{ V dc at } T_A = 25^\circ\text{C}$	Ris MIN.	$10^{12}$	$\Omega$
$V_{IO} = 500 \text{ V dc at } T_A \text{ MAX. at least } 100^\circ\text{C}$	Ris MIN.	$10^{11}$	$\Omega$
Safety maximum ratings (maximum permissible in case of fault, see thermal derating curve)			
Package temperature	$T_{si}$	175	°C
Current (input current $I_F, P_{si} = 0$ )	$I_{si}$	400	mA
Power (output or total power dissipation)	$P_{si}$	700	mW
Isolation resistance $V_{IO} = 500 \text{ V dc at } T_A = T_{si}$	Ris MIN.	$10^9$	$\Omega$

**Dependence of maximum safety ratings with package temperature**

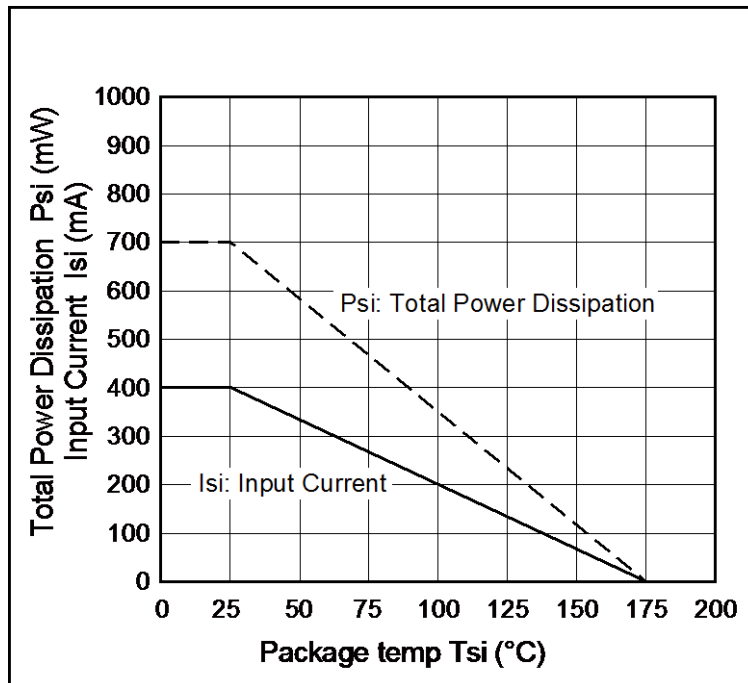

**Method a) Destructive Test, Type and Sample Test**

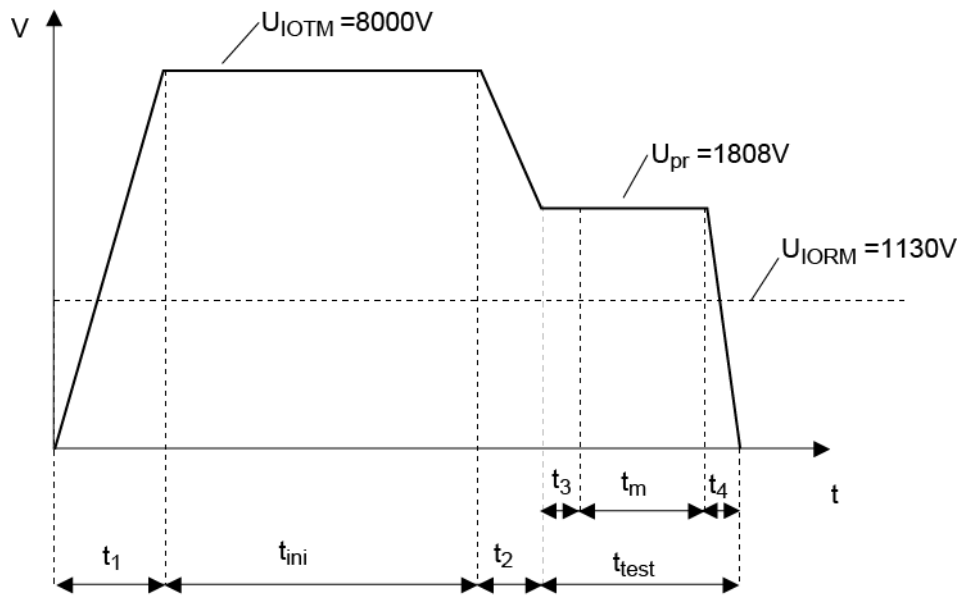

$t_1, t_2 = 1 \text{ to } 10 \text{ sec}$   
 $t_3, t_4 = 1 \text{ sec}$   
 $t_m(\text{PARTIAL DISCHARGE}) = 10 \text{ sec}$   
 $t_{\text{test}} = 12 \text{ sec}$   
 $t_{\text{ini}} = 60 \text{ sec}$

**Method b) Non-destructive Test, 100% Production Test**

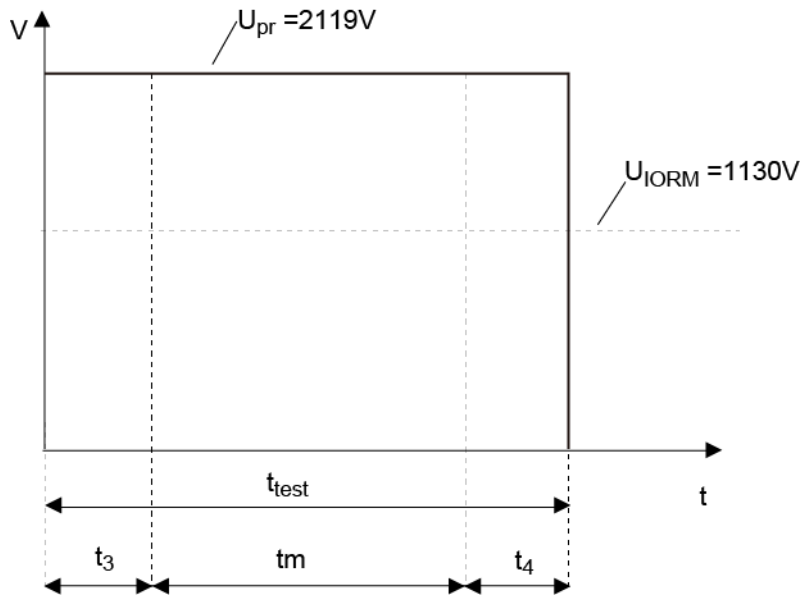

$t_3, t_4 = 0.1 \text{ sec}$   
 $t_m(\text{PARTIAL DISCHARGE}) = 1.0 \text{ sec}$   
 $t_{\text{test}} = 1.2 \text{ sec}$



**Caution**

GaAs Products

This product uses gallium arsenide (GaAs).

GaAs vapor and powder are hazardous to human health if inhaled or ingested, so please observe the following points.

- Follow related laws and ordinances when disposing of the product. If there are no applicable laws and/or ordinances, dispose of the product as recommended below.
  1. Commission a disposal company able to (with a license to) collect, transport and dispose of materials that contain arsenic and other such industrial waste materials.
  2. Exclude the product from general industrial waste and household garbage, and ensure that the product is controlled (as industrial waste subject to special control) up until final disposal.
- Do not burn, destroy, cut, crush, or chemically dissolve the product.
- Do not lick the product or in any way allow it to enter the mouth.