

Apr.1.2017 Copyright 2017 HIROSE ELECTRIC CO., LTD. All Rights Reserved.

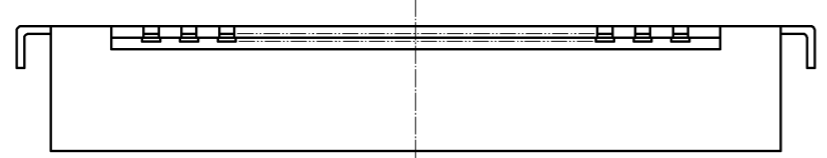

RECOMMENDED PATTERN

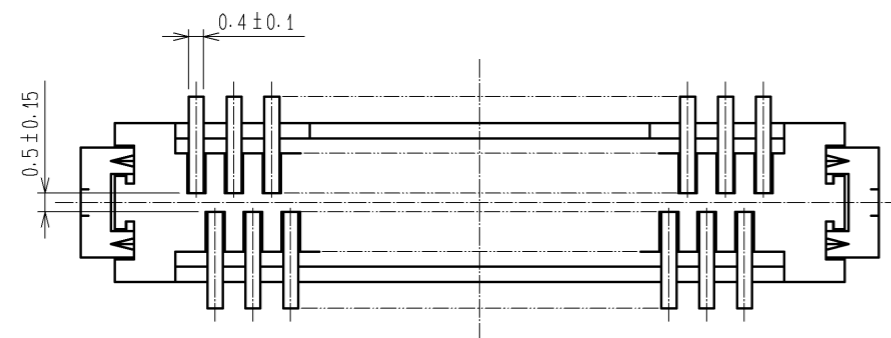
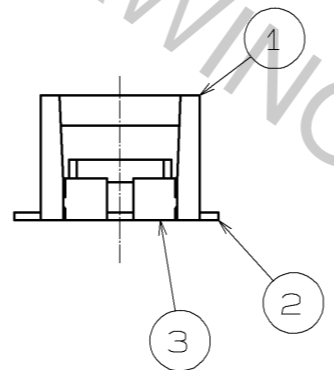
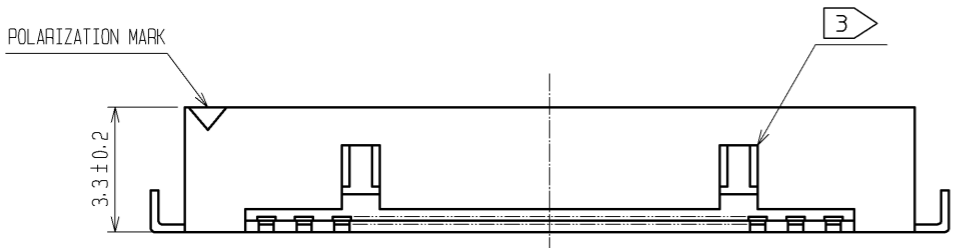
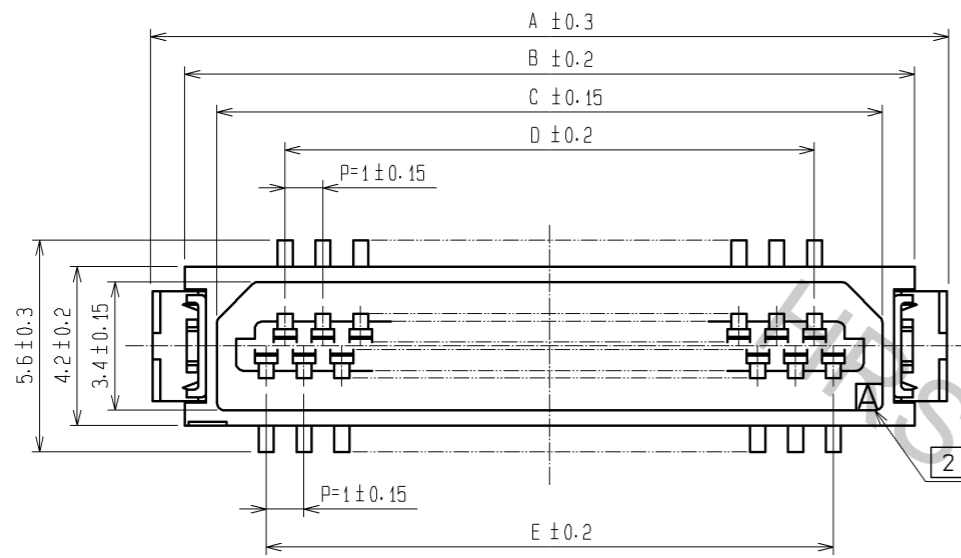
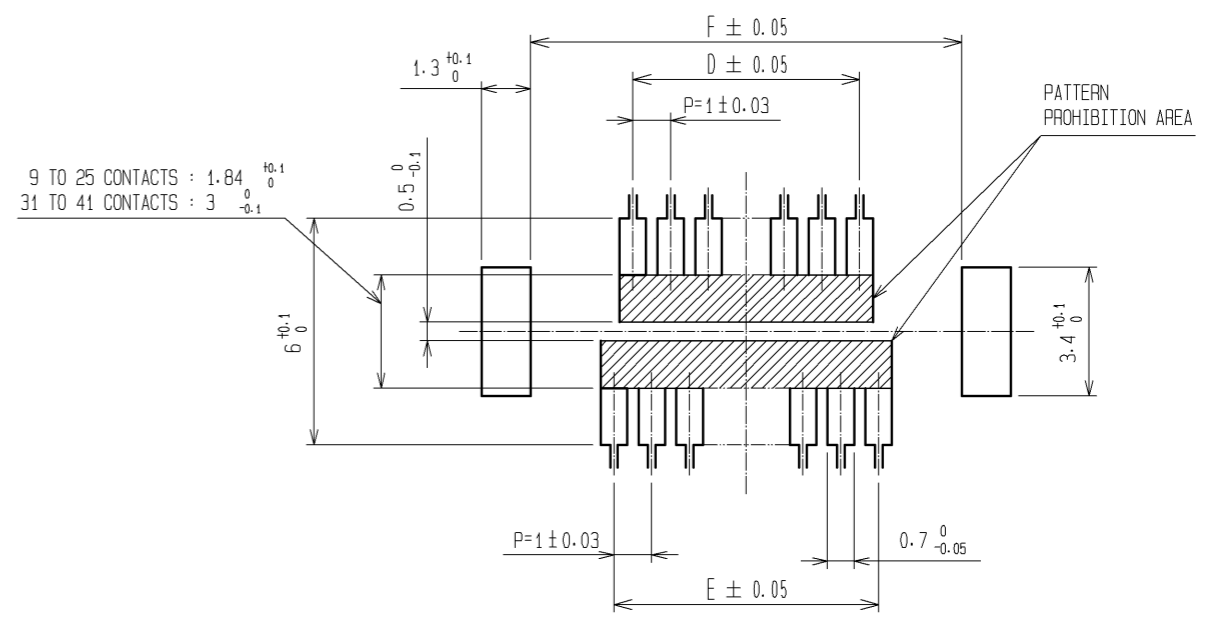

PART No.	CODE No.	NUMBER OF CONTACTS	A	B	C	D	E	F
DF9B- 9P-1V(32)	CL540-0134-7-32	9	10.1	8.3	6.6	3	4	8.4
DF9B-11P-1V(32)	CL540-0135-0-32	11	11.1	9.3	7.6	4	5	9.4
DF9B-13P-1V(32)	CL540-0136-2-32	13	12.1	10.3	8.6	5	6	10.4
DF9B-15P-1V(32)	CL540-0137-5-32	15	13.1	11.3	9.6	6	7	11.4
DF9B-17P-1V(32)	CL540-0138-8-32	17	14.1	12.3	10.6	7	8	12.4
DF9B-19P-1V(32)	CL540-0248-6-32	19	15.1	13.3	11.6	8	9	13.4
DF9B-21P-1V(32)	CL540-0140-0-32	21	16.1	14.3	12.6	9	10	14.4
DF9B-23P-1V(32)	CL540-0141-2-32	23	17.1	15.3	13.6	10	11	15.4
DF9B-25P-1V(32)	CL540-0142-5-32	25	18.1	16.3	14.6	11	12	16.4
DF9B-31P-1V(32)	CL540-0144-0-32	31	21.1	19.3	17.6	14	15	19.4
DF9B-41P-1V(32)	CL540-0221-0-32	41	26.1	24.3	22.6	19	20	24.4

NOTES 1 : LEAD CO-PLANARITY INCLUDE REINFORCED METAL FITTINGS SHALL BE 0.1mm MAX.
 ② CAV NO. IS INDICATED IN APPROX POSITION SHOWN.
 ③ 9 TO 25 CONTACT CONNECTORS HAVE ONE LOCK AT CENTER OF HOUSING.
 31 TO 41 CONTACT CONNECTORS HAVE TWO LOCKS AS PER DRAWING.

NO.	MATERIAL	FINISH .	REMARKS	NO.	MATERIAL	FINISH .	REMARKS
3	BRASS	SURFACE:TIN PLATED(REFLOW FINISH)1μm min UNDER PLATING:COPPER 0.3μm min		8	PS		CLEAR(REINFORCEMENT COLLAR)
2	PHOSPHOR BRONZE	TIN PLATED(HOT DIP) 1μm min		7	PS		BLACK(PLASTIC REEL)
1	POLYAMIDE	BEIGE, UL94V-0		6	POLYIMIDE		BROWN(HEAT-RESISTANCE TAPE)
				5	POLYESTER		CLEAR(COVER TAPE)
				4	PS		CLEAR(EMBOSSED CARRIER TAPE)

UNITS	SCALE	COUNT	DESCRIPTION OF REVISIONS	DESIGNED	CHECKED	DATE
mm	5 : 1	2	DIS-H-008010	YN. SAKAMOTO	YH. MICHIDA	13.07.05

APPROVED : KH. IKEDA	12.02.27	DRAWING NO.	EDC3-341299-02
CHECKED : AR. TAKAHASHI	12.02.24	PART NO.	DF9B-*P-1V(32)
DESIGNED : SH. HOSODA	12.02.24	CODE NO.	CL540-
DRAWN : KR. AJITO	12.02.24		

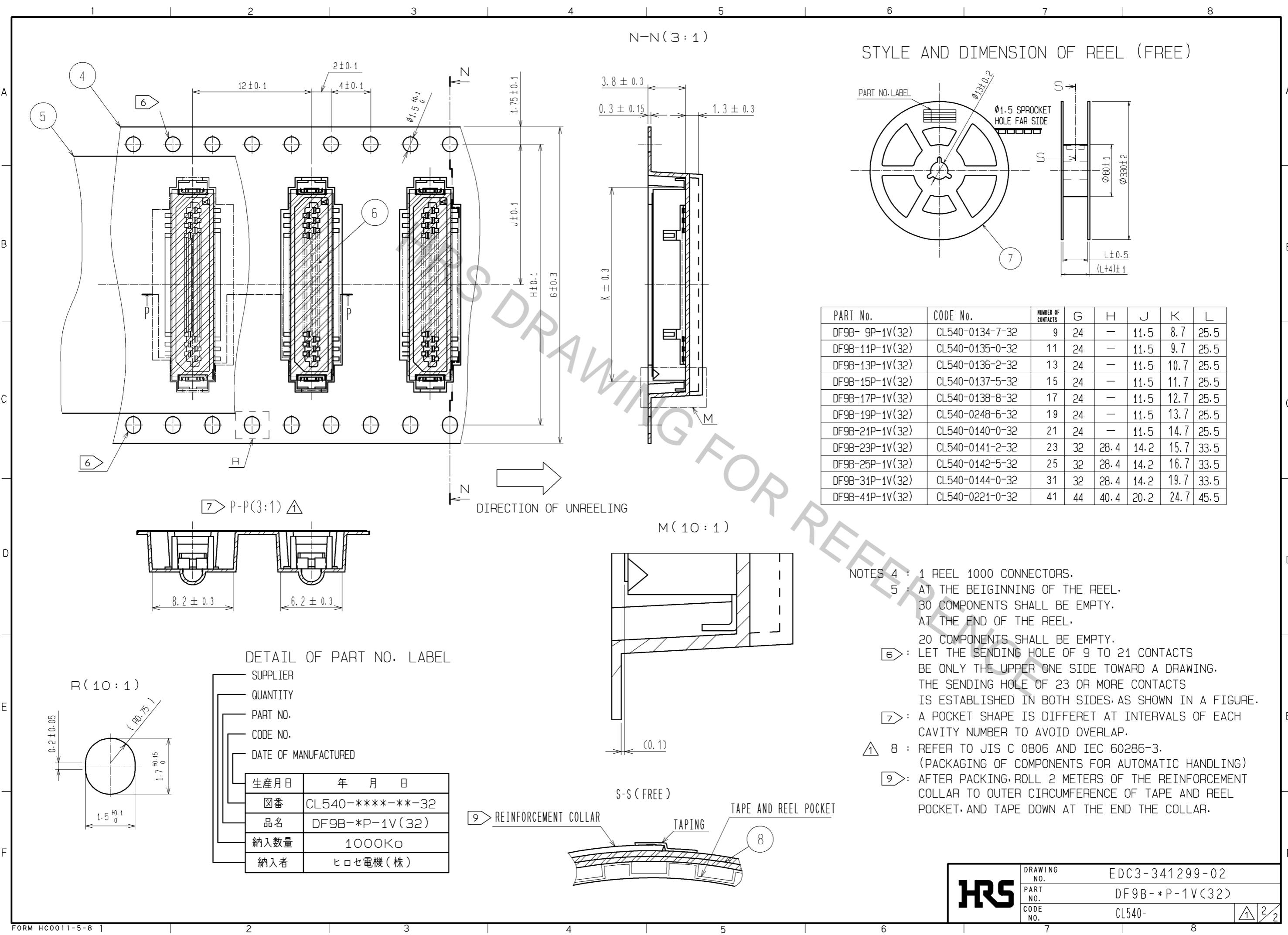

PART No.	CODE No.	NUMBER OF CONTACTS	G	H	J	K	L
DF9B-9P-1V(32)	CL540-0134-7-32	9	24	—	11.5	8.7	25.5
DF9B-11P-1V(32)	CL540-0135-0-32	11	24	—	11.5	9.7	25.5
DF9B-13P-1V(32)	CL540-0136-2-32	13	24	—	11.5	10.7	25.5
DF9B-15P-1V(32)	CL540-0137-5-32	15	24	—	11.5	11.7	25.5
DF9B-17P-1V(32)	CL540-0138-8-32	17	24	—	11.5	12.7	25.5
DF9B-19P-1V(32)	CL540-0248-6-32	19	24	—	11.5	13.7	25.5
DF9B-21P-1V(32)	CL540-0140-0-32	21	24	—	11.5	14.7	25.5
DF9B-23P-1V(32)	CL540-0141-2-32	23	32	28.4	14.2	15.7	33.5
DF9B-25P-1V(32)	CL540-0142-5-32	25	32	28.4	14.2	16.7	33.5
DF9B-31P-1V(32)	CL540-0144-0-32	31	32	28.4	14.2	19.7	33.5
DF9B-41P-1V(32)	CL540-0221-0-32	41	44	40.4	20.2	24.7	45.5

- NOTES
- 4 : 1 REEL 1000 CONNECTORS.
 - 5 : AT THE BEGINNING OF THE REEL, 30 COMPONENTS SHALL BE EMPTY. AT THE END OF THE REEL, 20 COMPONENTS SHALL BE EMPTY.
 - 6 : LET THE SENDING HOLE OF 9 TO 21 CONTACTS BE ONLY THE UPPER ONE SIDE TOWARD A DRAWING. THE SENDING HOLE OF 23 OR MORE CONTACTS IS ESTABLISHED IN BOTH SIDES, AS SHOWN IN A FIGURE.
 - 7 : A POCKET SHAPE IS DIFFERET AT INTERVALS OF EACH CAVITY NUMBER TO AVOID OVERLAP.
 - 8 : REFER TO JIS C 0806 AND IEC 60286-3. (PACKAGING OF COMPONENTS FOR AUTOMATIC HANDLING)
 - 9 : AFTER PACKING, ROLL 2 METERS OF THE REINFORCEMENT COLLAR TO OUTER CIRCUMFERENCE OF TAPE AND REEL POCKET, AND TAPE DOWN AT THE END THE COLLAR.

DETAIL OF PART NO. LABEL

—	SUPPLIER
—	QUANTITY
—	PART NO.
—	CODE NO.
—	DATE OF MANUFACTURED
生産月日	年 月 日
図番	CL540-****-**-32
品名	DF9B-*P-1V(32)
納入数量	1000K□
納入者	ヒロセ電機(株)

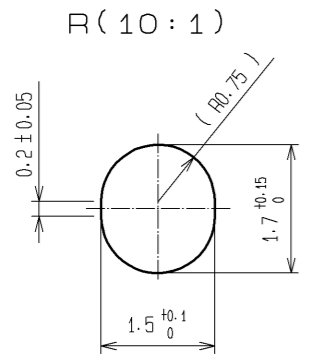

HRS	DRAWING NO.	EDC3-341299-02
	PART NO.	DF9B-*P-1V(32)
	CODE NO.	CL540-