

THIS DRAWING IS UNPUBLISHED. RELEASED FOR PUBLICATION .19
 © COPYRIGHT 19 BY AMP INCORPORATED, HARRISBURG, PA. ALL INTERNATIONAL RIGHTS RESERVED. AMP PRODUCTS MAY BE COVERED BY U.S. AND FOREIGN PATENTS AND/OR PATENTS PENDING.

REVISIONS					
P	F	ZONE	DESCRIPTION	DATE	APPROVED
✓		0	RELEASED PER PR 87-142 WAS 87-1169-25	10-13-87	KW/RS
		A	REV PER 0710-0927-95	24/06/95	RS

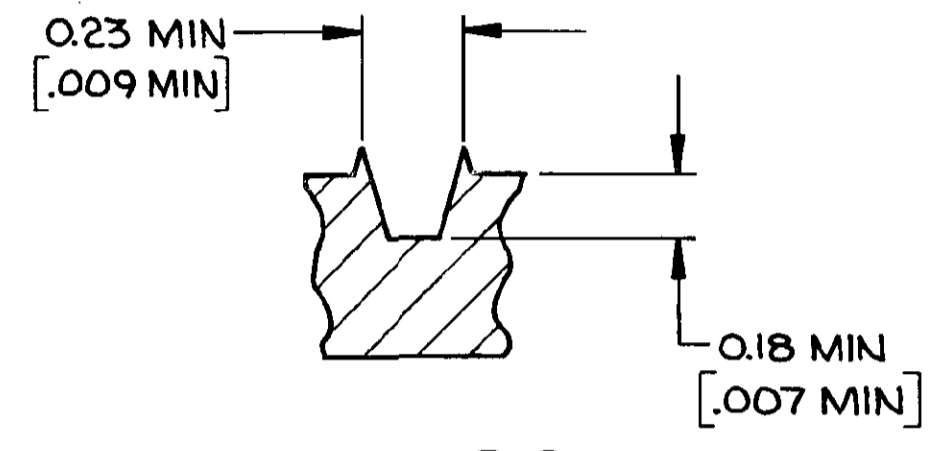

SECTION B-B
SCALE 50:1
5 PLACES

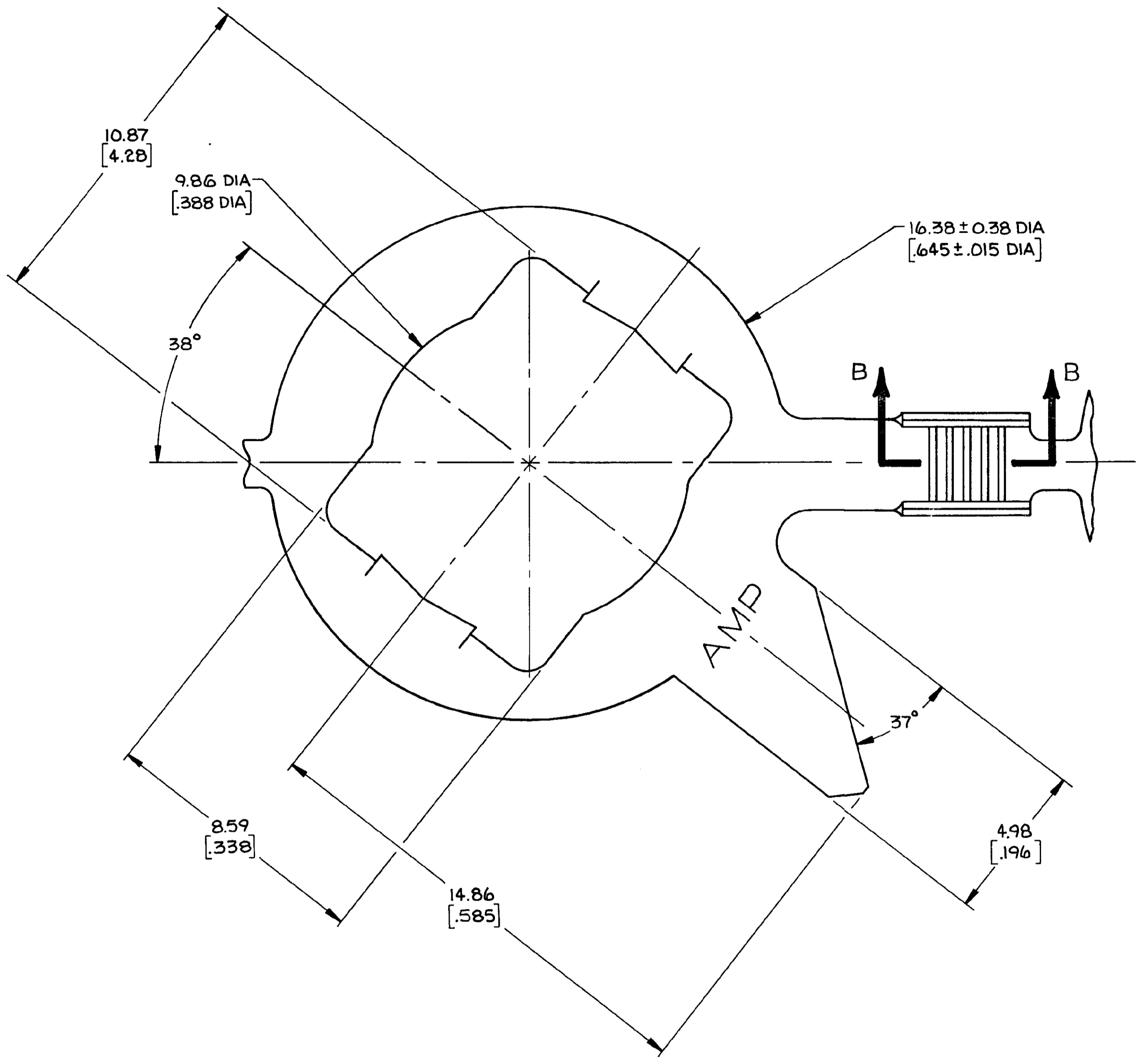
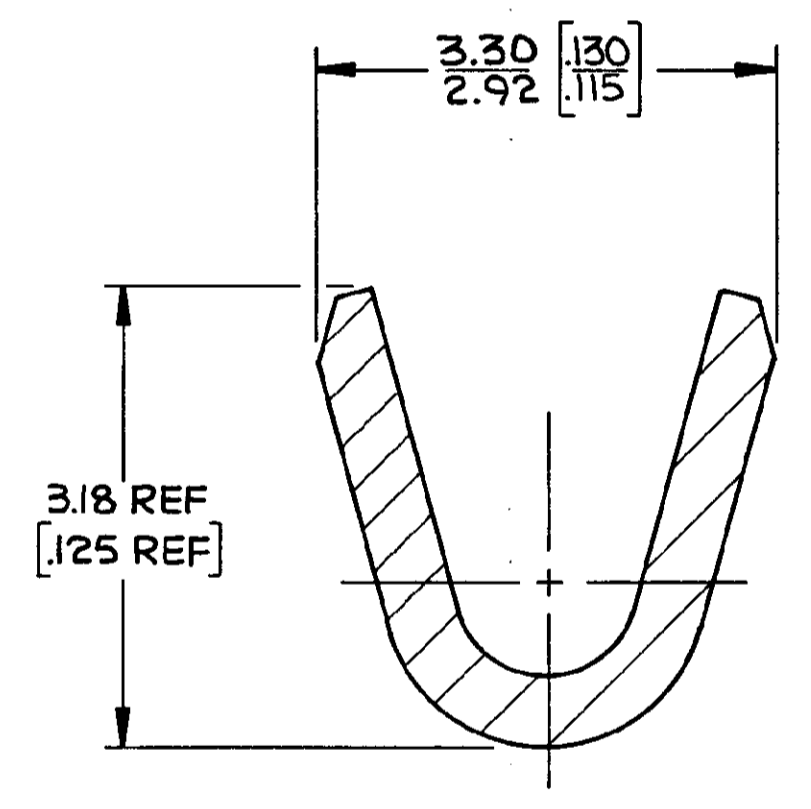

SECTION A-A
SCALE 20:1

1. WIRE RANGE : 20-16 AWG MAGNET.
2. DIMENSIONS IN BRACKETS ARE IN INCHES.

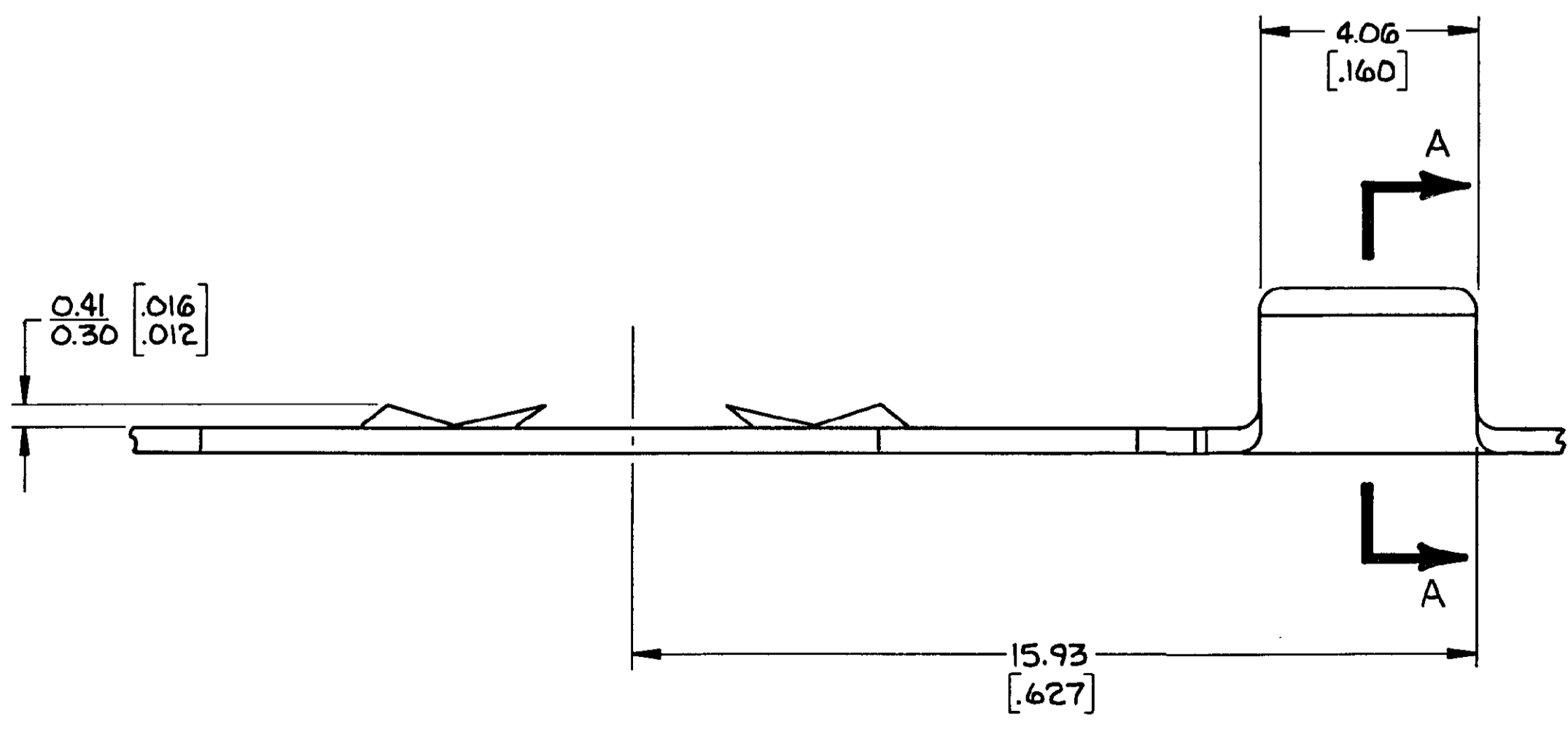

METRIC

UNLESS OTHERWISE SPECIFIED DIMENSIONS-MM ARE IN INCHES. TOLERANCES ON: DECIMALS ± .013 [.005] ANGLES ±		CONTRACT NO DR <i>X White</i> 10-13-87 CHK <i>R. Sving</i> 10-14-87 APPD <i>Don Lane</i> 14 Oct 87	AMP AMP INCORPORATED Harrisburg, Pa. 17105	
MATERIAL 050 BRASS [0198]	FINISH	DSGN APPD	OTHER APPD	NAME TERMINAL, STUD RETAINING RING, AMPLIVAR™
SIZE D	FSCM NO 00779	DRAWING NO 770371	770371-1 PART NO	
SCALE 10:1			SHEET 1 OF 1	