



QT-Brightek Optocoupler Series

RANDOM-PHASE TRIAC OPTOCOUPLER

Part No.: QTM301X/ QTM302X/ QTM305X series

Product: QTM301X/ QTM302X/ QTM305X series	Date: April 12, 2018	Page 1 of 12
	Version# 1.1	



Table of Contents:

Introduction3
Absolute Maximum Rating4
Electrical Characteristic ($T_A=25\text{ }^\circ\text{C}$).....5
Characteristic Curves.....6
Test Circuit for static dv/dt.....7
Packing & Labeling10
Ordering Information11
Revision History12
Disclaimer12

Introduction

Feature:

- High Isolation voltage between input and output (Viso = 3750V rms)
- Peak Breakdown Voltage
 - 250V – QTM3010, 3011, 3012
 - 400V – QTM3020, 3021, 3022, 3023
 - 600V – QTM3051, 3052, 3053
- Operating Temperature up to 100 °C
- Conventional black housing package

Schematic:

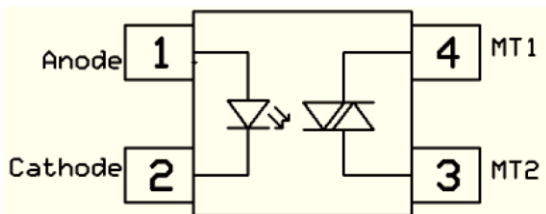

Certification & Compliance:

- Pb free and RoHS Compliant
- UL recognized (File #E338132)
- VDE (Pending Approval)



Dimension: (Dot location indicates pin 1)

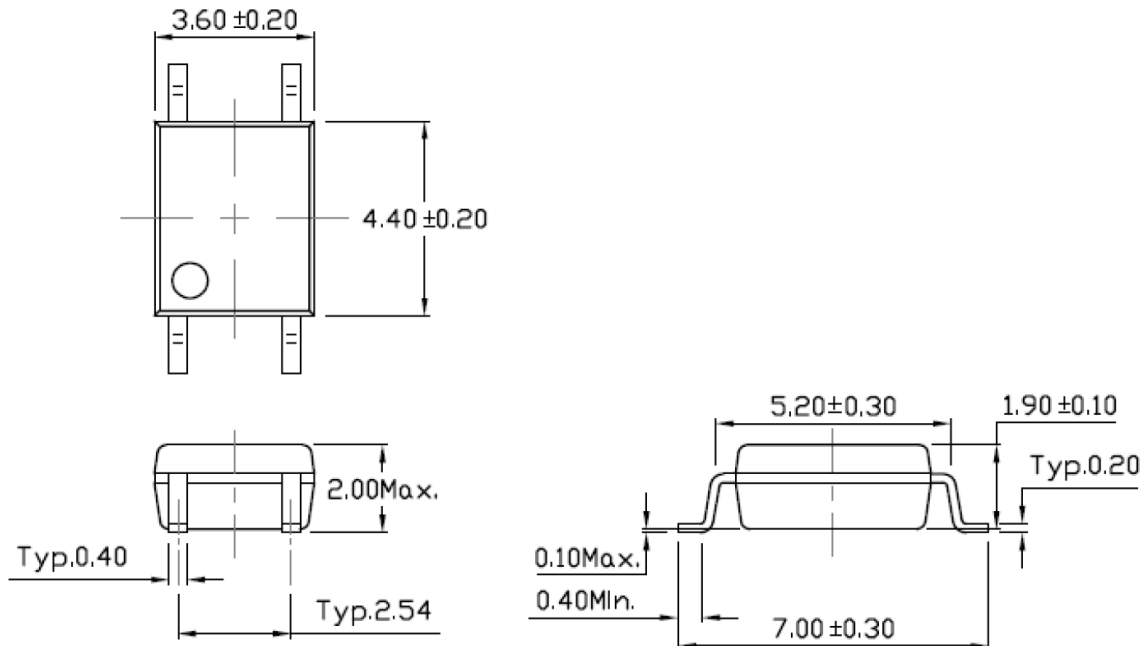

All Dimensions are in mm

**Absolute Maximum Rating**

Symbol	Parameter	Rating			Units
		Q301X series	Q302X series	Q305X series	
T _{STG}	Storage Temperature	-55 ~ 125			°C
T _{OPR}	Operating Temperature	-55 ~ 100			°C
T _{SOL}	Lead Solder Temperature	260 for 10 sec			°C
P _{TOT}	Total Power Dissipation	200			mW
EMITTER					
I _F	Continuous Forward Current	60			mA
I _{FP}	Peak Forward Current (≤ 1us, 300pps)	1			A
V _R	Reverse Voltage	6			V
P _D	Power Dissipation	100			mW
DETECTOR					
P _D	Power Dissipation	300			mW
	Power Dissipation Derated above 25 °C	4			mW/°C
V _{DRM}	Off-state Output Terminal Voltage	Q301X series	250		V
		Q302X series	400		
		Q305X series	600		
I _{TSM}	Peak Repetitive Surge Current	1			A

Electrical Characteristic (T_A=25 °C)

Emitter

Symbol	Characteristic	Test Condition	Range			Unit
			Min	Typ	Max	
V _F	Forward Voltage	I _F = 10mA	-	-	1.5	V
I _R	Reverse Current	V _R = 6V	-	-	5	μA
C _{IN}	Input Capacitance	f = 1kHz	-	45	-	pF

Detector

Symbol	Characteristic	Device	Test Condition	Range			Unit
				Min	Typ	Max	
I _{DRM}	Peak Blocking Current		V _{DRM} = Rated V _{DRM} , I _F = 0mA	-	-	100	nA
V _{TM}	Peak on-state voltage		I _{TM} = 100mA peak, I _F = Rated I _{FT}	-	-	2.5	V
dv/dt	Critical Rate of Rise off-state voltage	QTM301X series	V _{PEAK} = Rated V _{DRM} , I _F = 0 (refer to test circuit for dv/dt)	-	100	-	V/ μs
		QTM302X series		-	100	-	
		QTM305X series	V _{PEAK} = 600V, I _F = 0 (refer to test circuit for dv/dt)	1000	-	-	

Transfer Characteristic

Symbol	Characteristic	Device	Test Condition	Range			Unit
				Min	Typ	Max	
I _{FT}	LED Trigger Current	QTM3020	Main terminal voltage = 3V	-	-	30	mA
		QTM3010		-	-	15	
		QTM3021		-	-		
		QTM3051		-	-		
		QTM3011		-	-	10	
		QTM3022		-	-		
		QTM3052		-	-		
		QTM3012		-	-	5	
		QTM3023		-	-		
QTM3053	-	-					
I _H	Holding Current			-	250	-	μA
R _{IO}	Isolation Resistance		V _{IO} =500V _{DC}	1x10 ¹¹	-	-	Ω
C _{IO}	Isolation Capacitance		F=1MHz	-	0.25	-	pF

Characteristic Curves

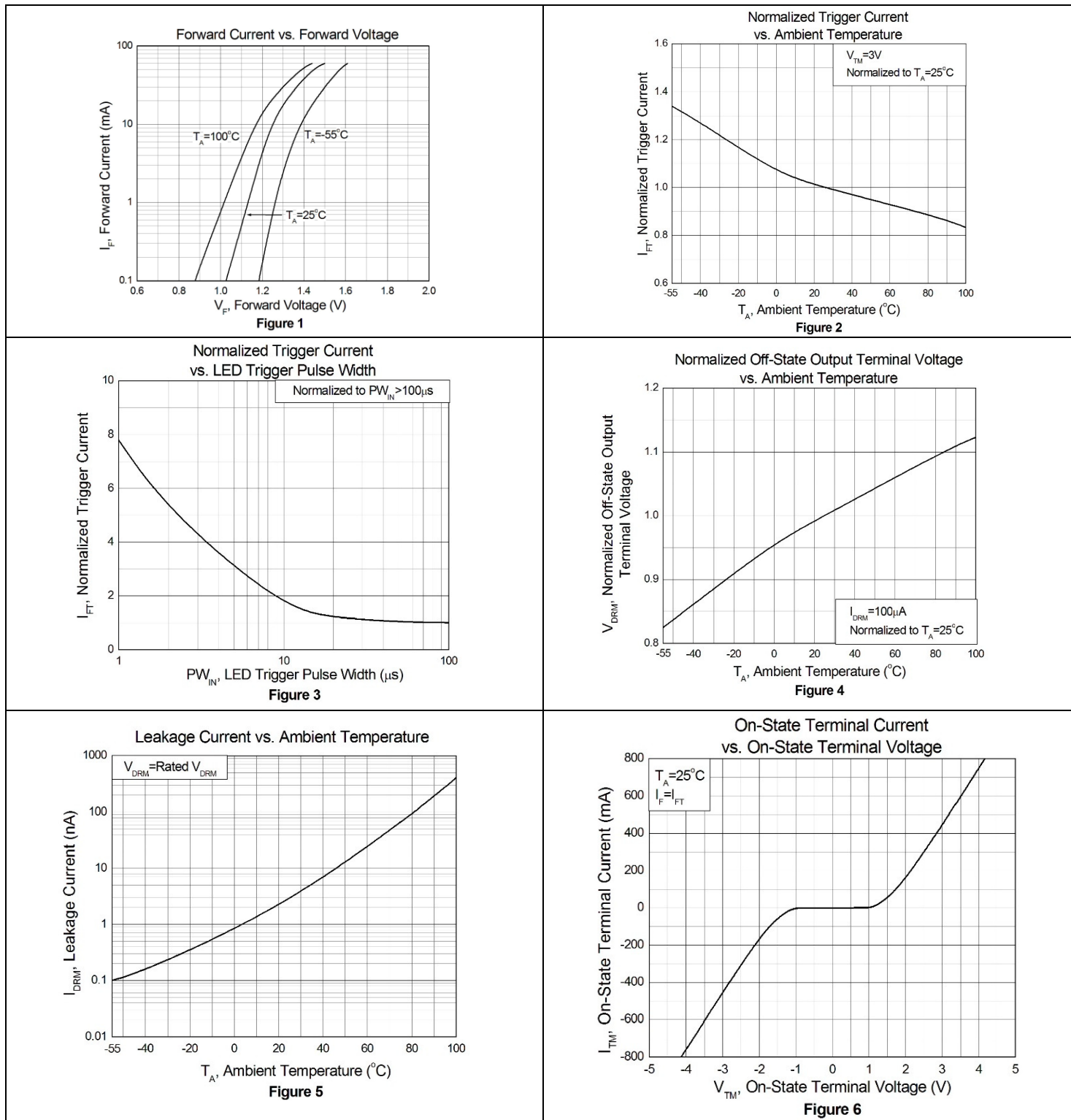

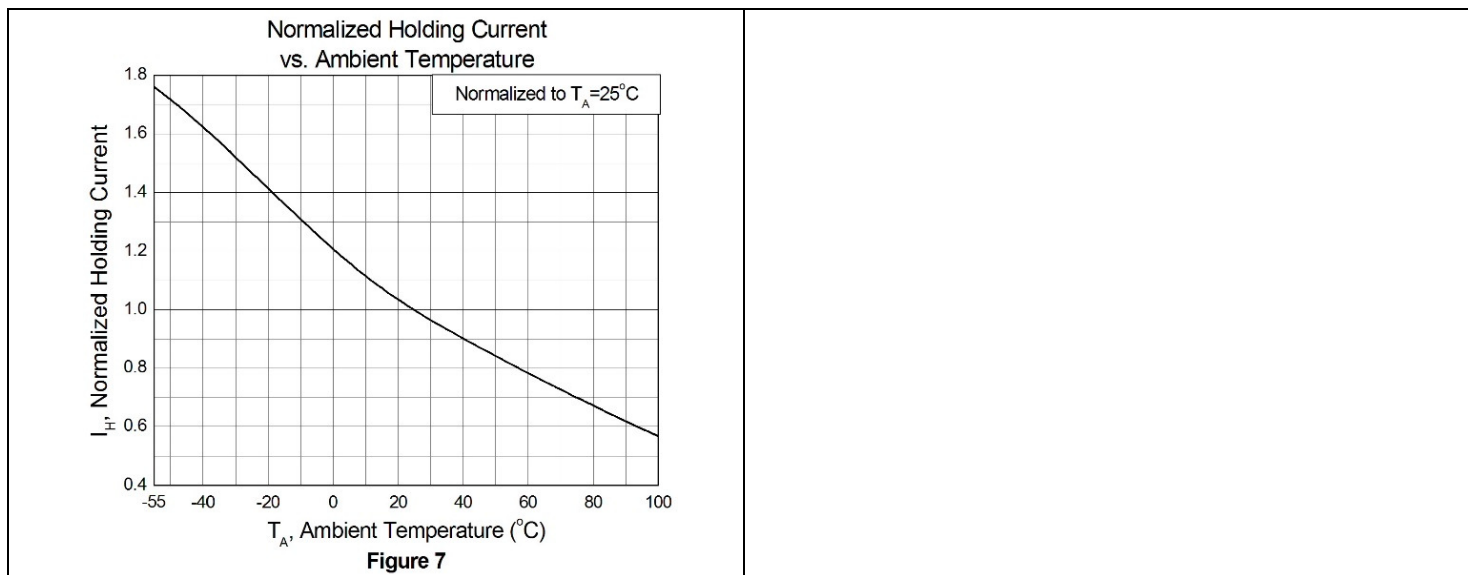

Test Circuit for static dv/dt

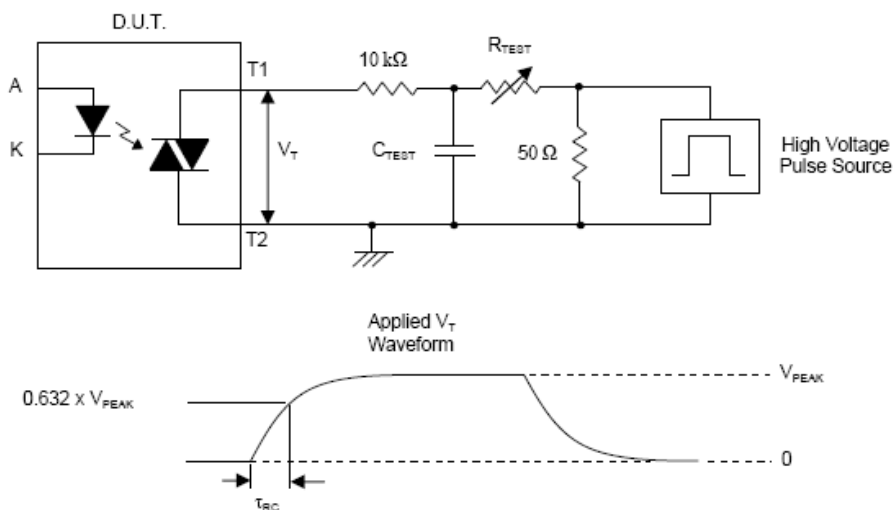

The high voltage pulse is set to the required V_{PEAK} value and applied to the D.U.T. output side through the RC circuit above. LED current is not applied. The waveform V_T is monitored using a x100 scope probe. By varying R_{TEST} , the dv/dt (slope) is increased, until the D.U.T. is observed to trigger (waveform collapses). The dv/dt is then decreased until the D.U.T. stops triggering. At this point, τ_{RC} is recorded and the dv/dt calculated.

$$dv/dt = \frac{0.632 \times V_{PEAK}}{\tau_{RC}}$$

Solder Profile & Footprint

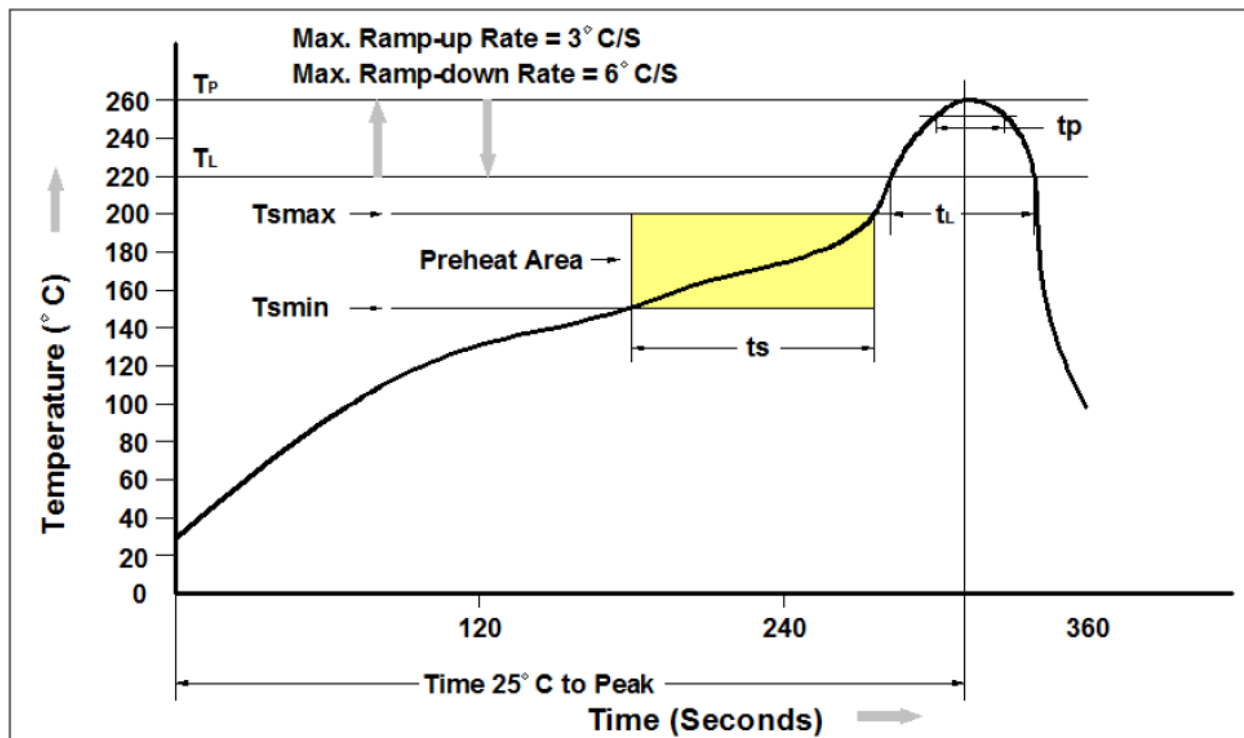

Profile Feature	Pb-Free Assembly Profile
Temperature Min. (T _{smin})	150 °C
Temperature Max. (T _{smax})	200 °C
Time (t _s) from (T _{smin} to T _{smax})	60-120 seconds
Ramp-up Rate (t _L to t _p)	3 °C/second max.
Liquidous Temperature (T _L)	217 °C
Time (t _L) Maintained Above (T _L)	60 – 150 seconds
Peak Body Package Temperature	260 °C +0 °C / -5 °C
Time (t _p) within 5 °C of 260 °C	30 seconds
Ramp-down Rate (T _P to T _L)	6 °C/second max
Time 25 °C to Peak Temperature	8 minutes max.

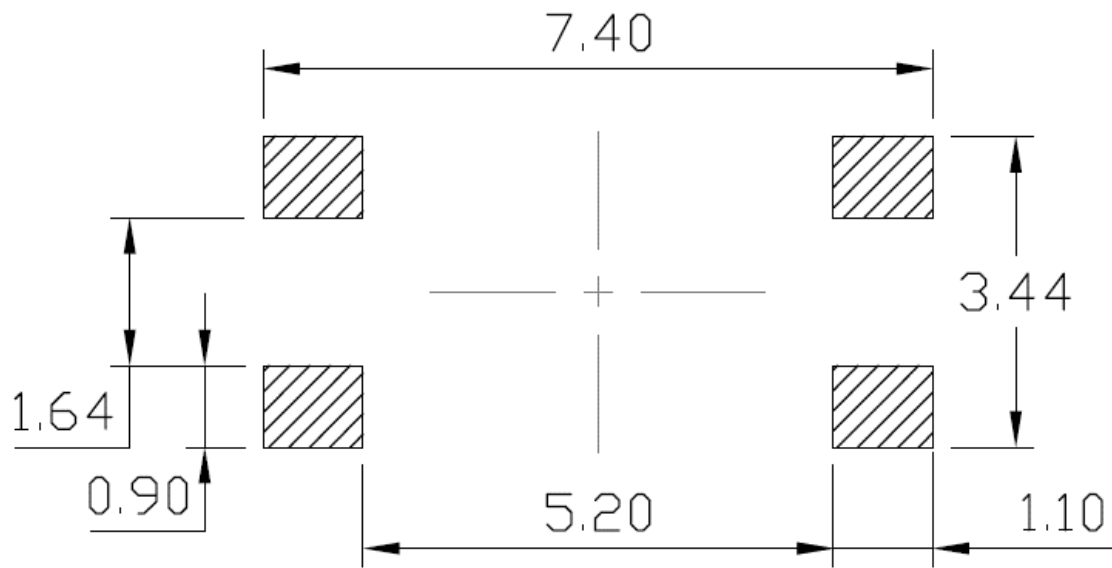

Recommended Solder Footprint for SMD Leadform

Units: mm

tolerance: +/- 0.1mm

Packing & Labeling

Tape Dimension:

Option T1

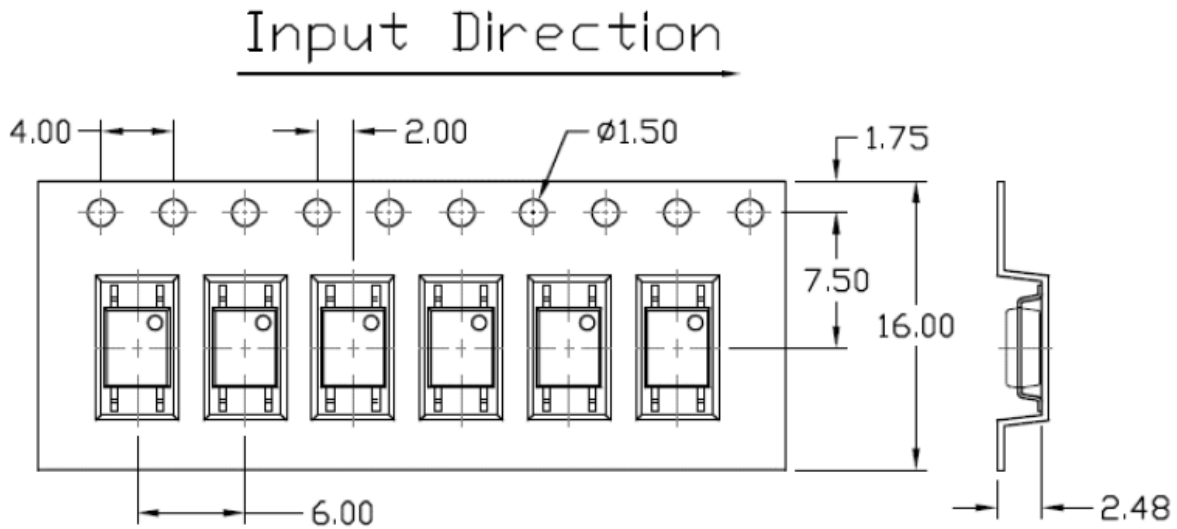

Option T2

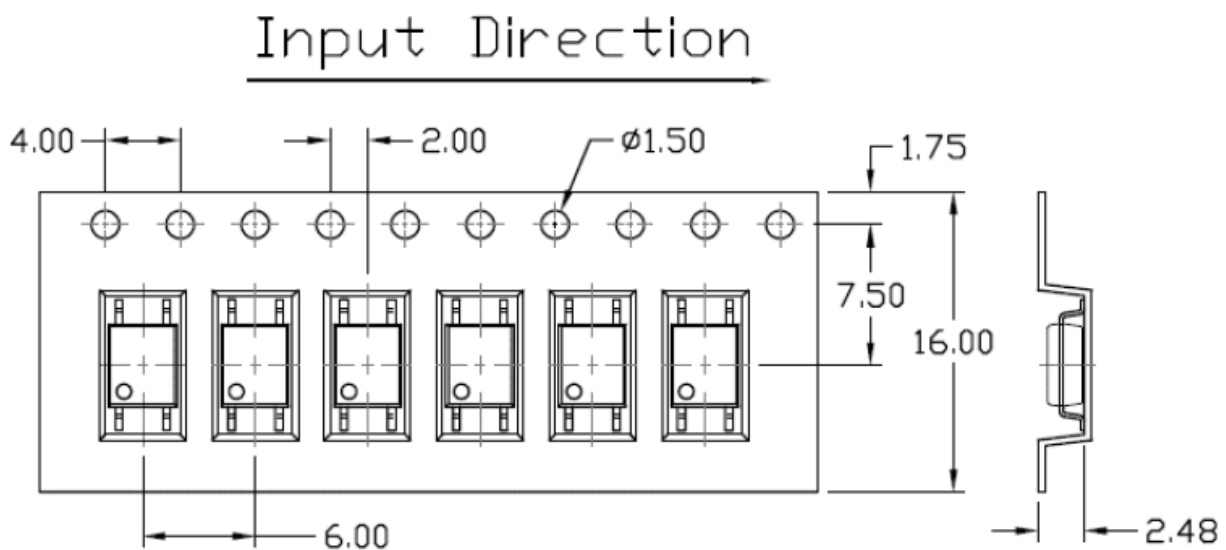

Unit: mm

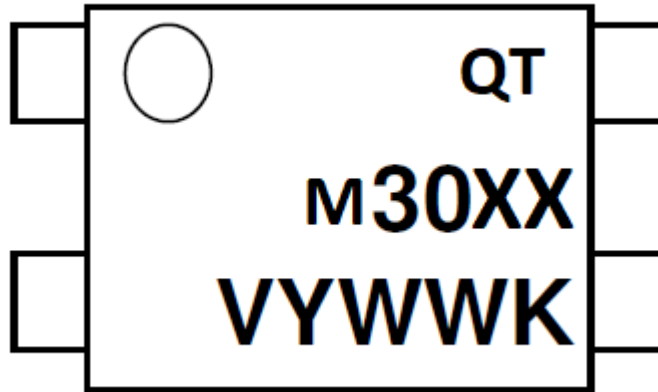
Device Marking:

QT = QT-Brightek Corporation
 M= Mini-Flat Package
 30XX = part number
 R= CTR Rank
 Y = Year
 WW = Week
 V = VDE Option
 K= Manufacturing code

Ordering Information

QTM30XX(V)(Z)

XX = Part number (X=10, 11, 12, 20, 21, 22, 23, 51, 52 or 53)

V = VDE option (V or None)

Z = Tape and reel option (T1 or T2)

Option	Description	Quantity
T1	Surface Mount Lead Forming – with Option 1 Taping	3000 pcs/ reel
T2	Surface Mount Lead Forming – with Option 2 Taping	3000 pcs/ reel



Revision History

Description:	Revision #	Revision Date
Initial of QTM301X /QTM302X/QTM305X series	1.0	02/08/2018
Amend the Marking	1.1	04/12/2018

Disclaimer

QT-BRIGHTTEK reserves the right to make changes without further notice to any products herein to improve reliability, function or design. QT-BRIGHTTEK does not assume any liability arising out of the application or use of any product or circuit described herein; neither does it convey any license under its patent rights, nor the rights of others.

Life Support Policy

QT-BRIGHTTEK's products are not authorized for use as critical components in life support devices or systems without the express written approval of QT-BRIGHTTEK. As used herein:

1. Life support devices or systems are devices or systems which, (a) are intended for surgical implant into the body, or (b) support or sustain life, and (c) whose failure to perform when properly used in accordance with instructions for use provided in the labeling, can be reasonably expected to result in a significant injury of the user.
2. A critical component in any component of a life support device or system whose failure to perform can be reasonably expected to cause the failure of the life support device or system, or to affect its safety or effectiveness.

Product: QTM301X/ QTM302X/ QTM305X series	Date: April 12, 2018	Page 12 of 12
	Version# 1.1	