

---

## Overview

This reference design demonstrates how to use Zilog's ZMOTION MCU in a passive infrared-based motion detector to control power to an AC load in applications such as lighting and HVAC systems. The design uses the Z8FS040 8-pin ZMOTION MCU to intelligently control a mechanical relay, and provides user adjustments for motion sensitivity, delay time, and ambient light level.

This document describes both hardware and software operation for the design.

- 
- **Note:** The source code file associated with this reference design, [RD0028-SC01.zip](#), is available free for download from the Zilog website. This source code has been tested with [ZDSII for Z8 Encore! version 5.2.0](#), which is available free for download from the Zilog Store. Subsequent releases of ZDSII may require you to modify the code supplied with this reference design.
- 

## Features

This ZMOTION AC Load Controller reference design features the following elements:

- Controls power to an AC load based on motion detection
- ZMOTION PIR Technology provides immunity to EMI/RFI and other false trigger sources
- 120VAC/240VAC 60Hz/50Hz input/output
- Switched AC line output for loads up to 5 A (limited by fuse and relay)
- Adjustable sensitivity, delay, and ambient light gate level
- Adjustments can be made from front or back side of board
- Supports six lenses with various patterns and ranges
- Smart Delay feature for *pass-through* events
- Delayed Detection Mode for harsh conditions
- Small two-layer single-board design, with a 2.7" x 1.7" (6.5cm x 4.3cm) footprint

Two of these features, Smart Delay and Delayed Detection, are further described on the next page.

**Smart Delay.** When motion is detected while the mechanical relay is powered off, the relay's running time is initially set to a maximum of 10 seconds rather than the full delay time set by the Time Delay potentiometer. If additional motion is detected within this 10-



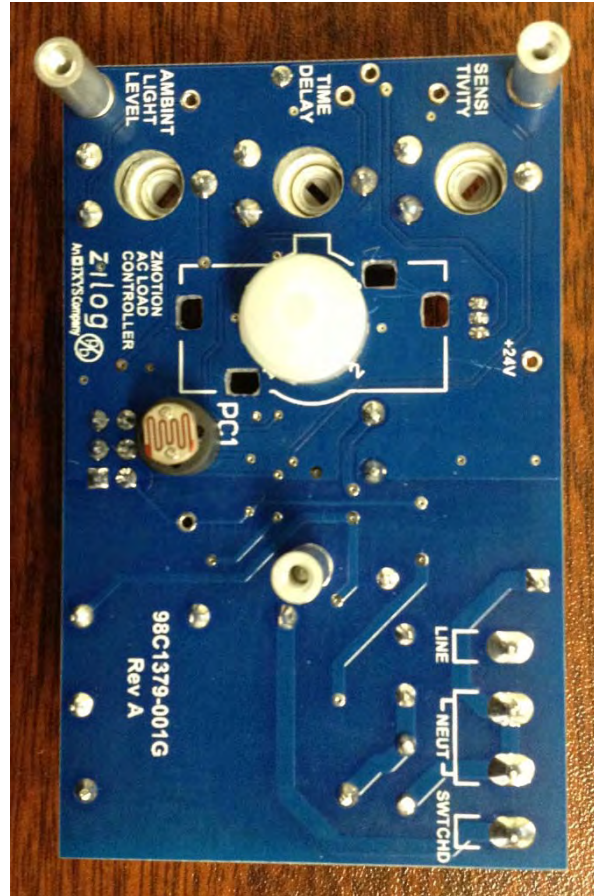

Figure 2. ZMOTION AC Load Controller Reference Design, Sensor Side

## Applications

The ZMOTION AC Load Controller reference design can be used to develop a number of applications; the brief list below offers a few ideas.

- Occupancy-based lighting control
- Doorway/hallway lighting control
- Closets and other small rooms
- Office cubicle lighting and power control
- Kiosk power control
- Retail displays
- Entrance and exit control
- Appliance power management
- HVAC Control

---

## Background

Passive infrared (PIR)-based motion detectors have been used in lighting control and related applications for many years. The ability to automatically turn on a light when a person enters a room and to turn it off automatically when no one is present provides a level of convenience and can significantly reduce energy consumption. Although simple analog-based motion detectors are capable of the basic functions of turning a load on and off, they typically suffer from poor sensitivity, false detections, and limited flexibility, often negating any of the advantages of an automated system. For example, a motion-based room lighting control system can be very frustrating to the end user if it does not pick up small micromotions, thereby causing the lights to turn off at inconvenient times. Also, airflow and sunlight can be the sources of false detections, causing the lights to turn on when no one is present.

With the continued increase in automated lighting and related applications, the need for a more intelligent, low-cost control system has become apparent. ZMOTION provides this capability.

The Z8FS040 ZMOTION MCU is a fully programmable microcontroller with built-in software-based motion detection algorithms to simplify the development of PIR motion detection designs. It is based on the Z8F082A MCU, a member of Zilog's Z8 Encore! XP family of Flash microcontrollers.

These motion detection algorithms comprise the ZMOTION Engine and run in the background of the MCU while control and status of the Engine is accessed through a software Application Programmer Interface (API). As a result, the designer can create application-specific software while taking advantage of Zilog's ZMOTION motion detection technology.

API settings are provided to match the operation of the ZMOTION Engine to each of the lens and pyroelectric sensor combinations provided.

## Hardware Discussion

The ZMOTION AC Load Controller reference design consists of a single PCB that connects directly to the AC line and controls power to an AC load via a relay. The Z8FS040 ZMOTION MCU provides motion detection, user interface, and output control functions. A low-cost capacitor-dropper power supply is used to provide power to the MCU and relay, but other power supply topologies, including switching and transformer types, are also possible. The ZMOTION MCU provides all timing and control functions in addition to motion detection.

For the discussion that follows, refer to the ZMOTION AC Load Controller block diagram in Figure 3 and to [Appendix A. Schematic Diagrams](#) on page 25.

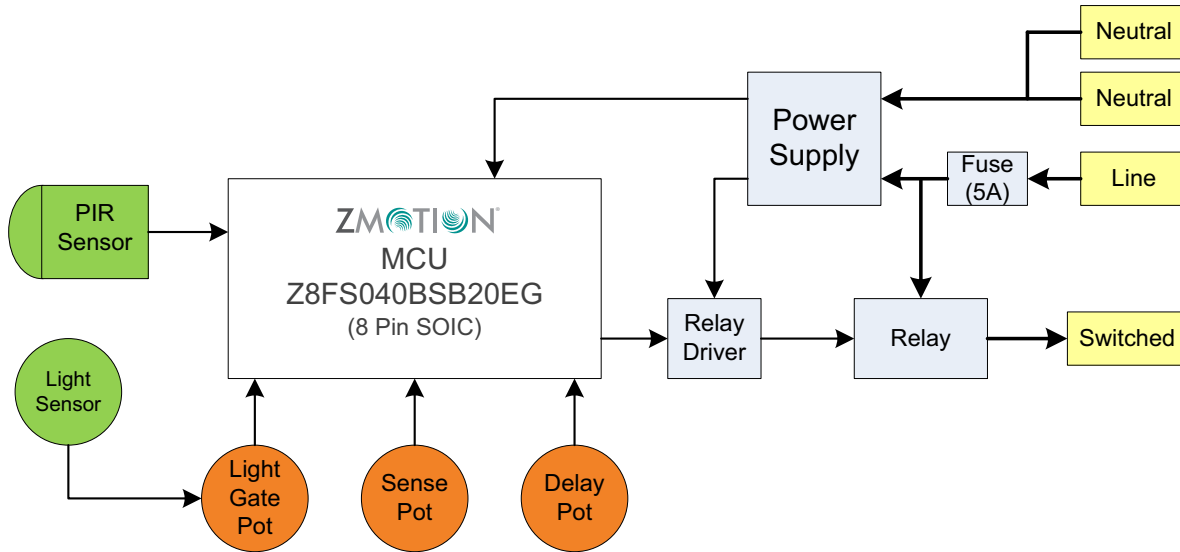

Figure 3. ZMOTION AC Load Controller Block Diagram

## Sensitivity and Time Delay

The Sensitivity potentiometer (R8) and Delay potentiometer (R1) provide a DC voltage to analog inputs ANA3 and ANA1 of the ZMOTION MCU, respectively. These inputs are monitored by the software at regular intervals. The inputs are measured alternately, once every three seconds.

The internal reference voltage ( $V_{REF}$ ) of the Z8FS040 MCU's ADC block is set to  $2.2V_{TYP}$  ( $2.0V_{MIN}/2.4V_{MAX}$ ). There are 15 discrete levels defined for the sensitivity and delay inputs (i.e., there are actually 16 levels implemented, but the software combines the two highest levels into a single setting). To ensure that the highest input setting can be sensed and, assuming a worst-case maximum  $V_{REF}$  of 2.4 V, the maximum input voltage to the ADC should be greater than 2.1 V, as computed in the following equation:

$$2.4V - 2 * 2.4V / 16 = 2.1V$$

The  $\pm 5\%$  39k $\Omega$  resistor,  $\pm 20\%$  100k $\Omega$  potentiometer and  $\pm 2\%$  3.3V power supply provide a minimum of 2.14 volts, as computed in the following equation:

$$(3.3V - 2\%) * ((100k\Omega - 20\%)) / ((100k\Omega - 20\%) + (39K + 5\%)) = 2.14V$$

## Ambient Light Circuit

The Ambient Light Sensor (PC1) is a PDV8103 CDS photocell. This device produces a resistance between 16k $\Omega$  and 33k $\Omega$  at 10 lux. ADC samples of the ambient light input are taken when motion is detected to determine if the relay should be turned on. The resistor divider created by PC1, R14 and R3 (100k $\Omega$  pot) allows the voltage produced by the ambient light level to be adjusted. The software uses a threshold voltage of  $1.4V_{TYP}$  ( $1.3V_{MIN} / 1.5V_{MAX}$ ) to decide if the relay should be engaged when motion is detected. If

the input voltage is equal to or greater than this threshold, the relay is engaged. If the input voltage is lower than this threshold, the relay is not engaged. After the relay is engaged, motion events that retrigger the relay ignore the ambient light level.

Using a typical threshold of 1.4V, Figure 4 shows the light level in lux units for the full scale range of the 100k $\Omega$  potentiometer. This figure presents how the light level threshold can be set to luminance levels between approximately 1 lux and 100 lux.

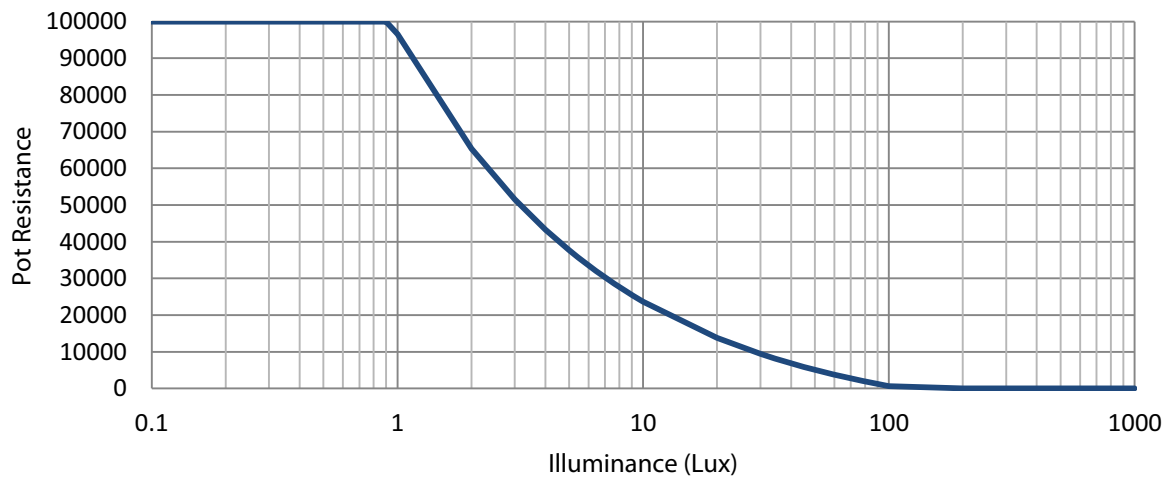

Figure 4. Ambient Light Threshold Settings

## Power Supply

Two voltages are required for circuit operation: 24VDC for the relay coil and 3.3V for the MCU and associated circuitry. To minimize cost, the power supply topology used is a capacitor-dropping type with a Zener regulator for the 24V and an LDO for the 3.3V. It can operate with an input from 230VAC at 50Hz to 105VAC at 60Hz. Other, more efficient topologies such as off-line switchers – or even transformer-based supplies – would also be acceptable.

The AC line input is fused at 5 A, which matches the maximum relay contact current. If using a different relay, the fuse value should be changed to match. A 275 V MOV (V1) provides protection from transient voltage spikes.

The power supply employs a full-wave bridge rectifier, which minimizes the value of the dropping capacitor C3 vs. a half-wave bridge rectifier. The supply is essentially a Zener regulator using the capacitive reactance of C3 and resistance of R10 to drop the voltage to the required level (in this case, 24 V). R10 (220 $\Omega$ ) is a metal oxide flame-proof device, the main function of which is to limit the in-rush current at power-on when C3 and C1 are discharged. Its value is selected as a balance between power dissipation and in-rush current limitation.

The 3.3V supply is derived from the 24V supply by VR1, a LP2950-33 Low Drop-Out regulator. The 3-pin TO-92 through-hole package is chosen to help keep heat away from the PCB, potentially affecting the pyroelectric sensor.

The maximum current requirements of the design are listed in Table 1.

**Table 1. General Current Requirements**

Design Element	Maximum Current
Zener current	2mA
Relay	8.3mA @ 24V
ZMOTION MCU	8mA, full run mode (worst case)
Other circuitry	1 mA
VR1 quiescent	0.1 mA
Total current	19.4mA

Because regulation of the 24 volts is not critical, we can operate very close to this worst-case condition.

Providing for worst-case component tolerances, 0.68μF is selected for the value of C3 to provide 21.3mA at 24V with a 114V AC, 59.94Hz input. A 275V, X2 type is used. The minimum AC input voltage required to supply 19.4mA is 105VAC at 60Hz.

The general computation for the output current supplied by this circuit is shown in the following equations.

$$I_{OUT} = \frac{\sqrt{2} * V_{AC} - V_Z}{\sqrt{2} * \left( \frac{1}{2\pi f C3} + R10 \right)}$$

Table 2 describes the values shown in the above equation and used to compute the three equations that follow.

**Table 2. Equation Values**

Parameter	Description (Tolerance)	Typical Value	Worst-Case Current Calculation
V <sub>AC</sub>	RMS AC input (±5% / ±10%)	120VAC / 230VAC	114VAC
V <sub>Z</sub>	Zener voltage (5%)	24V	25.2V
f	Line frequency (0.1%)	60Hz/50Hz	59.94Hz
C3	X2 capacitor (10%)	0.68μF	0.612μF
R10	Series Resistance (5%)	220Ω	231Ω

Plugging in the worst-case current (i.e., the lowest current available) values from Table 2 yields the following calculation:

$$I_{OUT} = \frac{\sqrt{2} * 114V - 25.2V}{\sqrt{2} * \left( \frac{1}{2\pi * 59.94Hz * 612nF} + 231\Omega \right)} \rightarrow 21.3mA$$

The nominal current available with a 120VAC 60Hz supply is computed as:

$$I_{OUT} = \frac{\sqrt{2} * 120V - 24V}{\sqrt{2} * \left( \frac{1}{2\pi * 60Hz * 680nF} + 220\Omega \right)} \rightarrow 25.4mA$$

Finally, the nominal current available with a 130VAC 50Hz supply is computed as:

$$I_{OUT} = \frac{\sqrt{2} * 230V - 24V}{\sqrt{2} * \left( \frac{1}{2\pi * 50Hz * 680nF} + 220\Omega \right)} \rightarrow 44.0mA$$

## Zener Power Dissipation

The maximum power dissipated by Zener Diode D1 occurs under a fault condition of no load when the system is running from a 230VAC supply. This fault condition only occurs if the voltage regulator VR1 fails or if the MCU erroneously enters a low-power stop mode, but these cases should still be considered. The worst-case current through the Zener ( $I_z$ ) is calculated similar to the calculations above, but with the values listed in Table 3.

**Table 3. Current Requirements When Using A Zener Diode**

Parameter	Description (Tolerance)	Typical Value	Worst-Case Current Calculation
$V_{AC}$	RMS AC input ( $\pm 5\%/\pm 10\%$ )	120VAC / 230VAC	253VAC
$V_Z$	Zener voltage (5%)	24V	25.2V
f	Line frequency (0.1%)	60Hz/50Hz	50.05Hz
C3	X2 capacitor (10%)	0.68 $\mu$ F	0.748 $\mu$ F
R10	Series resistance (5%)	220 $\Omega$	209 $\Omega$



---

Plugging in the worst-case current (i.e., the lowest current available) values from Table 3 yields the following calculation:

$$I_Z (\text{max}) = \frac{\sqrt{2} * 253\text{V} - 25.2\text{V}}{\sqrt{2} * \left( \frac{1}{2\pi * 50.05\text{Hz} * 748\text{nF}} + 209\Omega \right)} \rightarrow 53.4\text{mA}$$

$$P_Z (\text{max}) = 53.5\text{mA} * 25.2\text{V} \rightarrow 1.35\text{W}$$

The nominal power dissipated by the Zener diode with a 120VAC 60Hz supply is:

$$P_Z (\text{nom}) = 25.4\text{mA} * 24\text{V} \rightarrow 0.61\text{W}$$

Finally, the nominal power dissipated by the Zener diode with a 230VAC 50Hz supply is:

$$P_Z (\text{nom}) = 44.0\text{mA} * 24\text{V} \rightarrow 1.06\text{W}$$

Based on these calculations, the Zener diode selected for this application is rated at 1.5W.

## R10 Power Dissipation

The maximum power dissipated by the in-rush current-limiting resistor R10 must also be considered under the no-load fault condition. In this case, we must use a resistance value corresponding to its maximum tolerance value of 231Ω. Under this condition, the maximum current is reduced to 53.25mA, but the higher resistance value produces greater power dissipation.

Note the following calculation:

$$P_R (\text{max}) = (53.25\text{mA})^2 * 231\Omega \rightarrow 0.65\text{W}$$

The nominal power dissipated by the R10 resistor with a 120VAC 60Hz supply is:

$$P_R (\text{nom}) = (25.4\text{mA})^2 * 220\Omega \rightarrow 0.14\text{W}$$

The nominal power dissipated by the R10 resistor with a 230VAC 50Hz supply is:

$$P_R (\text{nom}) = (44.0\text{mA})^2 * 220\Omega \rightarrow 0.43\text{W}$$

Based on these calculations, the resistor selected for this application is a flame-proof metal oxide resistor rated at 1.0W.

## Load Control

The AC load is switched by relay K1, a 5 A/250 V device with a 24 VDC coil that requires 8.3 mA pull-in current. The coil is energized when PA2 of the ZMOTION MCU drives the gate of FET Q2 High. D2 absorbs the inductive kickback generated by the coil when it is deenergized. The relay contacts are connected to the AC line input after fuse F1. This fuse limits the current through the relay contacts and to the load.

To increase the load-switching capability for your own design, use a relay and fuse with a higher current rating. Also ensure that the trace widths are capable of supporting the additional current.

## PCB Design and Layout

A few simple precautions should be followed when designing any PIR-based motion detection product:

- Changes in in temperature near the sensor can create false detections.
  - Any heat-dissipating components should be kept away from the pyroelectric sensor.
  - Remove any heat-transferring copper directly under the pyroelectric sensor.
  - Include a thermal spacer between the sensor and the PCB.
- Ensure that the signal trace from the pyroelectric sensor to the MCU is short and direct.
- Keep the power ground traces between the MCU and sensor direct and short; do not route to other components between.
- Ensure minimum PCB trace spacings are observed for all high-voltage nets.

## Manufacturing Precautions

The performance of the pyroelectric sensor can be affected by excessive heating. Therefore, Zilog recommends that the following precautions be observed during PCB assembly.

### Soldering

- The sensor should be hand-soldered using a calibrated soldering iron set to a maximum temperature of 350°C.
- Avoid applying heat to the pins for more than five seconds without allowing cooling time.
- Excessive heat may cause deterioration of the sensor's performance.

### Washing

- Ensure that all flux is washed out after soldering, because any remaining flux may cause degradation in performance.
- The device is hermetically sealed; therefore, an aqueous clean may be used.

- A brush is recommended for washing. Washing with an ultrasonic cleaner may cause operational failure.
- Ensure that the sensor window is clean and free of any washing chemicals or other contaminants prior to installing the lens.

## MCU Production Programming

The ZMOTION MCU is provided with only the ZMOTION Engine preprogrammed. The application code must still be programmed into the chip during manufacture. Several options exist for programming the MCU, both out-of-circuit and in-circuit.

### Out-of-Circuit Programming

- Use a Zilog-approved third-party single or gang device programmer to program the device prior to assembly.
- With this programming method, the 6-pin header P1 is not required. However, pull-up resistors R4 and R12 are still required. Any value between 10k $\Omega$  and 47k $\Omega$  is suitable.
- Refer to the Zilog website for [a list of approved third-party programmers](#).

### In-Circuit Programming with a USB SmartCable

- For small-to-medium volume production, the ZMOTION MCU can be programmed in-circuit using Zilog's USB SmartCable ([ZUSBSC00100ZACG](#)) and the Smart Flash Programmer application (available in the [Zilog Store](#): Product ID SD00017).
- The device is programmed through the debug interface.
- Because the ZMOTION AC Load Controller Module's power supply does not provide any circuit isolation, any programming device connected to this module (such as a PC) must be isolated, typically with an isolation power transformer.
- Alternately, the device can be powered without being connected to an AC main by providing an externally-generated  $V_{CC}$  source (3.3V).

### In-Circuit Programming via Tester or ATE

- For high-volume production, the ZMOTION MCU can be programmed in circuit by the same equipment that is being used to test the circuit board.

## Software Discussion

The firmware for this reference design was developed using [ZDSII for Z8 Encore! version 5.2.0](#), which is available free for download from the Zilog Store (Product ID #SD00027). All application source code is available in the [RD0028-SC01.zip](#) file, which is available free for download from the Zilog website.

## Project Files

The ZMOTION AC Load Controller project includes the following source and header files:

**Delay\_Pot.c.** Input measurement of Delay Potentiometer; delay setting look-up table.

**Delay\_Pot.h.** Configuration of Delay Potentiometer settings.

**Sense\_Pot.c.** Input measurement of Sensitivity Potentiometer; sensitivity look-up table.

**Sense\_Pot.h.** Configuration of Sensitivity Potentiometer settings.

**main.c.** Main application source code.

**main.h.** Configuration of code operation.

**API\_INIT\_XXXX.h.** ZMOTION API lens settings; filename matches the lens being used.

There are three standard files that are included as part of every ZMOTION project:

**startupePIR.asm.** Custom ZMOTION start-up module (reset).

**ePIR\_API.c.** Memory space definitions for the ZMOTION Engine API.

**ePIR\_API.h.** ZMOTION API register bit definitions.

## ZDSII Project Configuration

To accommodate the ZMOTION Engine and API, the following address space settings must be used:

ROM: 0000–0FFF  
RData: 20–4F, F0–FF, C7–C8  
EData: 100–10F, 110–18F

Memory model: Small  
Frames: Static  
Parameter passing: Register

## Software Flow

The application consists of a main loop and two interrupt sources: ADC and Timer 0. Halt Mode is used in the main loop, causing it to be executed once after either interrupt. The ADC interrupt passes control to the ZMOTION Engine, which performs all motion detection processing and updates the API, then returns to the calling function. The ADC is run in Continuous Mode; therefore this interrupt is generated once every 256 system clocks (about once every 46.2 $\mu$ s). The Timer 0 interrupt runs once every 100ms and controls all software timers used in the main loop. It also sets the required one-second time base bit in the ZMOTION API and controls the deactivation of the relay.

Figure 5 shows a high-level flow of the ZMOTION AC Load Controller Reference Design firmware.

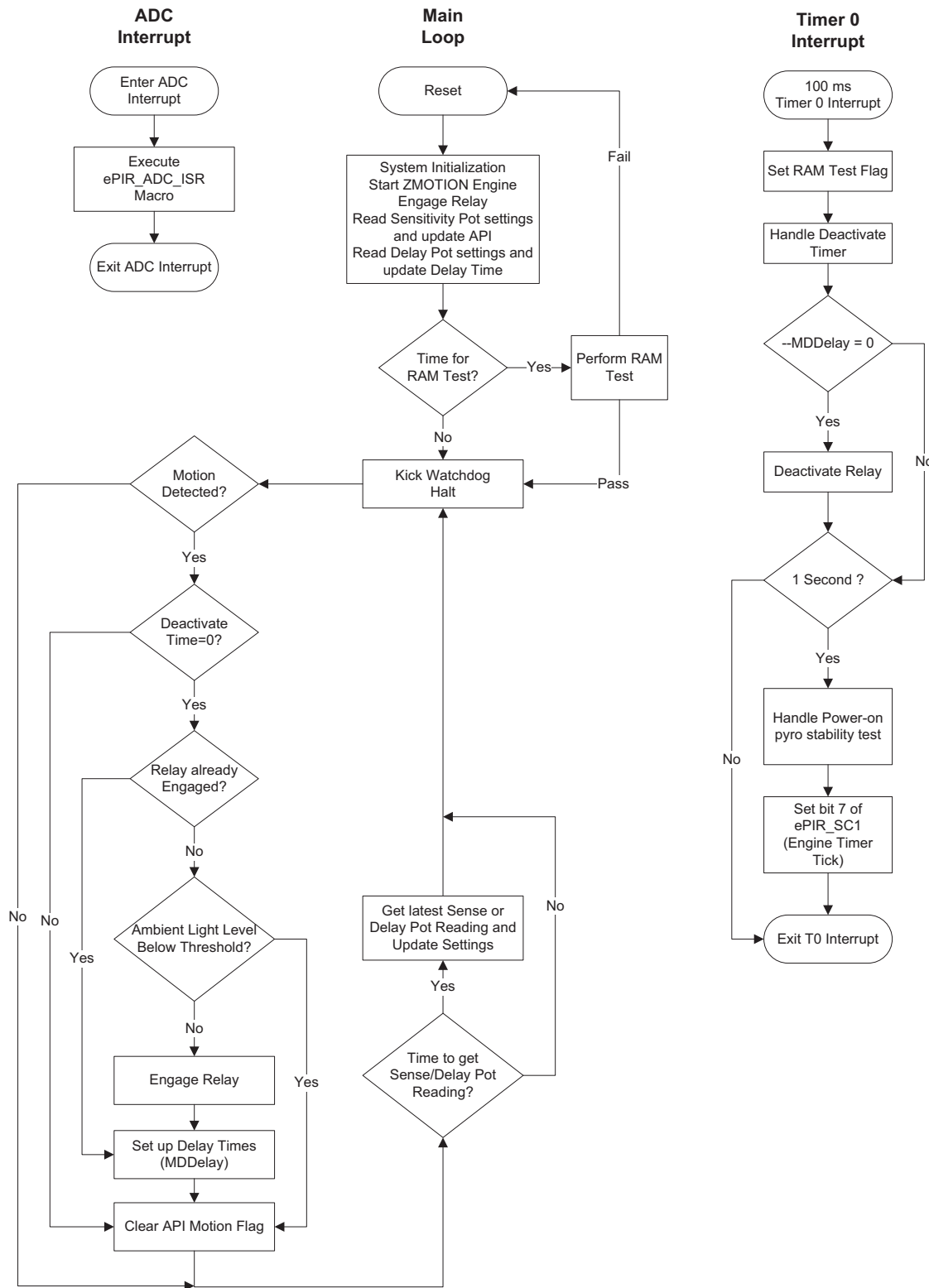

Figure 5. Software Flow

## Source Code Configuration

Multiple parameters for lens configuration, delay settings and sensitivity levels are provided in the [RD0028-SC01](#) source code file, as this section describes.

### Lens Configuration

API settings are provided in the form of header files to match the operation of the ZMOTION Engine to each lens. These files are labeled `API_INIT_XX.h`, wherein `XX` represents the particular lens. See the [Supported Lenses section](#) on page 17 for a list of the supported lenses and their associated configuration files. Other lenses can be used, and additional lens configuration files are available; contact your local [Zilog Sales Office](#), or create a support ticket with [Zilog Customer Service](#).

An additional lens configuration file, `API_INIT_ACLC.h`, is included as a single set of generic settings that provide satisfactory performance for all six lenses. To select a specific lens configuration file, remove the comments around it in `main.h`. Only a single lens configuration file can be used at a time.

### Smart Delay

The Smart Delay parameters listed in Table 4 are defined in the `main.h` header file.

**Table 4. Smart Delay Parameters**

Configuration Parameter	Description	Default
SMART_DELAY_ENABLE	Enable Smart Delay feature (1); Disable Smart Delay feature (0)	1: Enabled
SMART_DELAY_TH	Minimum Delay time setting before Smart Delay will be used. If the delay pot is set lower than this value, the Smart Delay feature is not used.	20 seconds
SMART_DELAY_TIME	The delay time used for the initial motion event and events up to SMART_DELAY_COUNT when Smart Delay is enabled. After SMART_DELAY_COUNT events have been detected within the SMART_DELAY_TIME	10 seconds
SMART_DELAY_COUNT	The number of motion events needed to be detected during the SMART_DELAY_TIME time before the actual pot delay value will be used.	3 motion events

## Delayed Detection

The Delayed Detection parameters listed in Table 5 are defined in the `main.h` header file.

**Table 5. Delayed Detection Parameters**

Configuration Parameter	Description	Default
DETECTION_DELAYED	Enable Delayed Detection feature (1); Disable Delayed Detection feature (0)	1: Enabled
ACTIVE_DETECT_TIME_THRESHOLD	This is the minimum delay setting for which ACITVE_DETECT_TIME is used. For delay settings below ACTIVE_DETECT_TIME_THRESHOLD, Delay/2 is used.	5 Minutes
ACTIVE_DETECT_TIME	Amount of time at the end of delay cycle to start looking for motion. Motion is ignored before this time.	1 Minute

## Lens Testing

When LENS\_TESTING is set to 1, the Delay Time setting is overridden and a hard-coded delay time is used to indicate which ZMOTION Engine detected a motion event. If the load is switched on for 2 seconds, the *Normal* Engine detected the motion event. If the load is switched on for 5 seconds, the *Extended* Engine detected the motion event. This configuration is defined in the `main.h` file, and should not be used at the same time as the Noise Testing configuration.

## Noise Testing

When NOISE\_TESTING is set to 1, the Delay Time setting is overridden and a hard-coded delay time is used to indicate when either noise or transients have been detected by the ZMOTION Engine. If the load is switched on for 1 second, the Engine has detected a transient event. If the load is switched on for 0.5 seconds, the Engine has detected a noise event. This configuration is defined in the `main.h` file, and should not be used at the same time as the Lens Testing configuration.

## Light Gate Threshold

The Light Gate Threshold is defined by the LG\_THRESHOLD variable in the `main.h` file. It determines the ADC reading from the ambient light sensor input that will allow the relay to be engaged. ADC readings below this value will stop the relay from being engaged; ADC readings equal to or above this value will allow the relay to be engaged when motion is detected. This value may need to be changed when using a different CDS photocell than specified.

## Delay Table

Delay times are defined by the `Delay_Table[]` array in the `Delay_Pot.c` file. 16 entries are defined in this table, their default values provide delays ranging from 2 seconds

to 5 minutes. The last two entries in the table are identical due to the tolerance of the ADC reference voltage (to learn more, see the [Sensitivity and Time Delay section](#) on page 5). This range can be changed by entering different delay times in the table. A second table is included (commented out) that provides delay times ranging from 2 seconds to 30 minutes. The first entry corresponds to the lowest ADC reading and the longest delay value. Either table may be modified as required by the application.

### Sensitivity Table

The motion sensitivity level is defined by the `Sense_Table[]` array in the `Sense_Pot.c` file. Two main motion detection algorithms run on the MCU as part of the ZMOTION Engine: one is the *normal detector*, and the other is the *extended detector*. The normal detector looks for significant changes in the signal within adjustable parameters to generate a motion event. The extended detector is controlled separately, and is intended to detect higher- and lower-speed objects and micromotions. The settings for both of these Engines are adjusted separately via the API in real time by reading the input voltage provided by the Sensitivity pot.

Two settings control the sensitivity of the normal detector: the `ePIR_Sensitivity` Register and the Range field of the `ePIR_SC2` Register. The Extended Detection bits of the `ePIR_SC0` Register control the sensitivity of the extended detector. A 16-entry table is used to control each of these three settings based on the input voltage. When the ADC reading is taken, it is shifted to a 4-bit value to provide the 16 discrete levels. The last two entries in the table are identical due to the tolerance of the ADC internal reference voltage (to learn more, see the [Sensitivity and Time Delay section](#) on page 5).

In Figures 6 through 8, the first table entry corresponds to the lowest pot voltage input and the most sensitive setting. A semilogarithmic scale is used for the `ePIR_Sensitivity` Register setting to provide a linear feel for sensitivity to motion; a linear scale is used for the Range setting. An extended detection level is also calculated on a logarithmic scale to disable the extended detector less than halfway through the table.

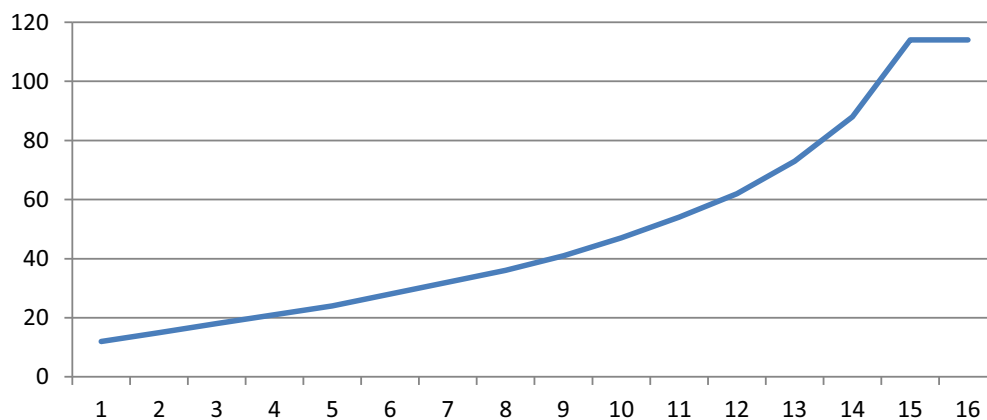

Figure 6. ePIR\_Sensitivity Register Settings



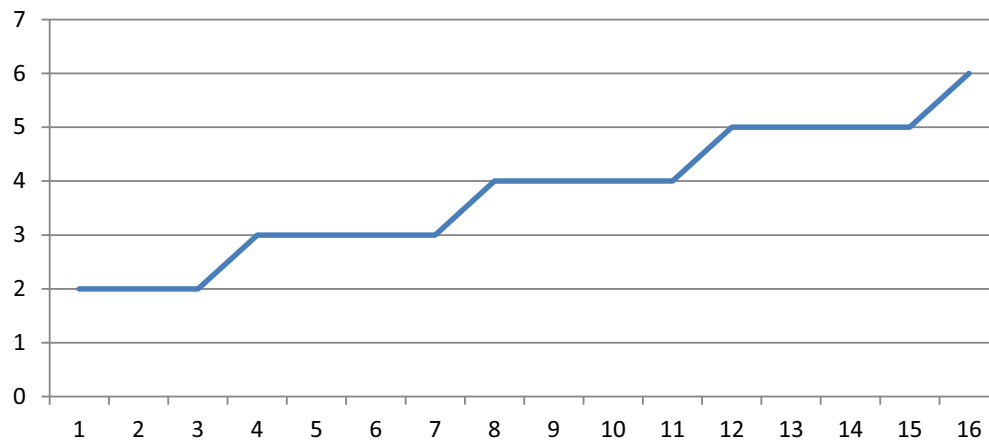

Figure 7. Range Register Settings

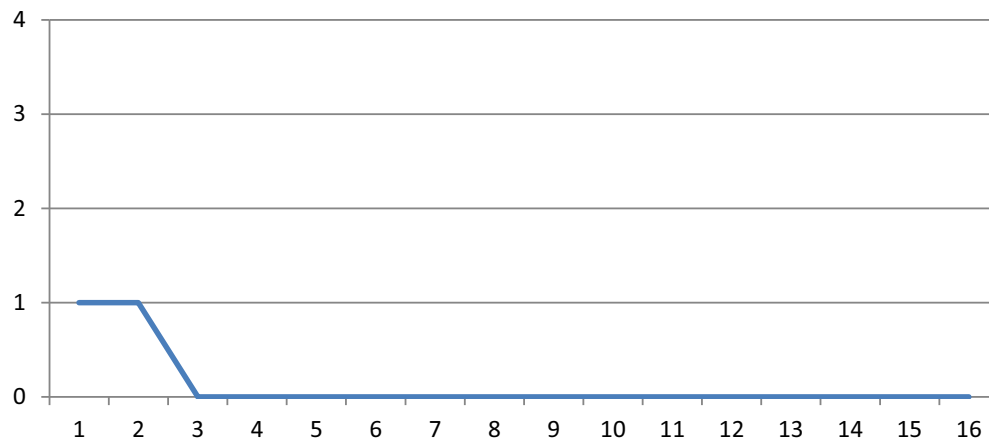

Figure 8. Extended Range Register Settings

The above figures are graphic representations of the sensitivity table using the default API settings defined in the generic lens configuration file, `API_INIT_ACLC.h`. By including a lens configuration file with different default settings, the sensitivity table is automatically recalculated when the source code is compiled. As a result, there should be no need to adjust the entries in the Sensitivity table.

## Supported Lenses

The lenses listed in Table 6 have been tested with this ZMOTION AC Load Controller reference design. Other lenses may be used, but may require specific API settings or modified firmware. For a complete list of tested lenses and configuration files, please refer to the [ZMOTION Lens and Pyro Sensor Configuration Guide \(WP0018\)](#).

Table 6. Supported Lenses

Lens Part Number and Configuration File	Description	Typical Applications
ZNCL-9(26) API_INIT_05	<b>15 mm Ceiling/Wall Array (360°)</b> <ul style="list-style-type: none"> <li>• Clips on to pyroelectric sensor</li> <li>• 2.25 m radius at 2 m height</li> <li>• 2:1 diameter-to-height coverage ratio</li> </ul>	<b>Room occupancy and proximity sensing</b> <ul style="list-style-type: none"> <li>• Lighting control</li> <li>• Appliance</li> <li>• Office cubicle</li> <li>• HVAC Control</li> <li>• Kiosk/display control</li> <li>• Vending power management</li> </ul>
ZNCL-10IL API_INIT_06	<b>10 mm Wall Mount Array (70°)</b> <ul style="list-style-type: none"> <li>• Clips on to pyroelectric sensor</li> <li>• 6 beams (X); 2 beams (Y)</li> <li>• 10 meter range</li> </ul>	<b>Proximity sensing or entrance detection</b> <ul style="list-style-type: none"> <li>• Kiosk/Display Counters</li> <li>• Vending</li> <li>• HVAC</li> <li>• Entrance/Access Control</li> </ul>
ZNCL-3B API_INIT_07	<b>10 mm Wall Mount Array (40°)</b> <ul style="list-style-type: none"> <li>• Clips on to pyroelectric sensor</li> <li>• 4 beams (X); 2 beams (Y)</li> <li>• 10 meter range</li> </ul>	<b>Proximity sensing or entrance detection</b> <ul style="list-style-type: none"> <li>• Kiosk/Display Counters</li> <li>• Vending</li> <li>• HVAC</li> <li>• Entrance/Access Control</li> </ul>
ZNCL-10R API_INIT_13	<b>10 mm Wall Mount Array (360°)</b> <ul style="list-style-type: none"> <li>• Clips on to pyroelectric sensor</li> <li>• 2:1 diameter-to-height coverage ratio</li> <li>• 14 zones</li> <li>• 5 meter range</li> </ul>	<b>Room occupancy and proximity sensing</b> <ul style="list-style-type: none"> <li>• Lighting Control</li> <li>• HVAC Control</li> <li>• Appliances</li> <li>• Kiosk/display control</li> <li>• Vending power management</li> </ul>
ZNCL-10S API_INIT_12	<b>10 mm Wall Mount Array (17°)</b> <ul style="list-style-type: none"> <li>• Clips on to pyroelectric sensor</li> <li>• 2 beams (X); 1 beams (Y)</li> <li>• 10 meter range</li> </ul>	<b>Proximity sensing or entrance detection</b> <ul style="list-style-type: none"> <li>• Kiosk/display counters</li> <li>• Vending</li> <li>• HVAC</li> <li>• Entrance/access control</li> </ul>
ZNCL-11 API_INIT_08	<b>23 mm x 11 mm Wall Mount Array (104°)</b> <ul style="list-style-type: none"> <li>• Mounts on circuit board; black rectangular lens</li> <li>• 32 zones</li> <li>• 4 meter range</li> </ul>	<b>Room and occupancy sensing</b> <ul style="list-style-type: none"> <li>• Kiosk/display counters</li> <li>• Appliance power management</li> <li>• Vending</li> <li>• TV auto shut-off</li> <li>• Office cubicle</li> <li>• Keypad motion detector</li> </ul>
Generic API_INIT_ACLC	<b>Generic API settings to provide satisfactory performance for all lenses listed in this table.</b>	<b>Allows all lenses listed in this table to be used with the same software build.</b> Better performance can be achieved by using the specific lens configuration file defined for the lens.

## Connecting the ZMOTION AC Load Controller

Observe the following procedure to properly set the connections on the ZMOTION AC Load Controller; Figure 9 presents a visual guide.

1. Ensure that AC power is off.
2. For initial operation, adjust the potentiometers to the following positions:
  - Set the Sensitivity pot to the center
  - Set the Time Delay pot all the way to –
  - Set the Ambient Light Level pot all the way to +
3. Connect the AC line to the J1 terminal labeled **LINE**.
4. Connect the AC Neutral to the J1 terminal labeled **NEUT**.
5. From the device to be switched, connect the Line wire to the J1 terminal labeled **SWITCHD**.
6. Also from the device to be switched, connect the Neutral wire to the J1 terminal labeled **NEUT**.
7. Apply AC power.

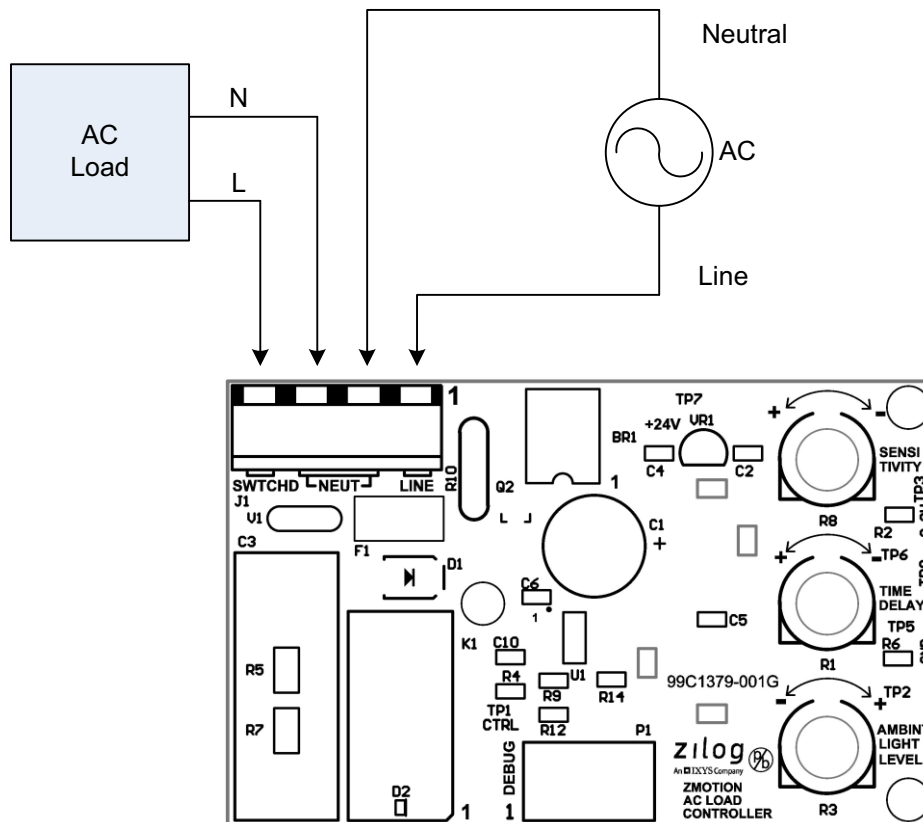

Figure 9. ZMOTION AC Load Controller Connections



**Warning:** The ZMOTION AC Load Controller Module is electrically connected to AC power and contains points with high voltage. When connecting a computer or other device to this Module (including test instruments), separate isolation must be provided to avoid damage to the connected equipment and to avoid possible electrical shock. Persons working with this Module should be fully qualified to work with high-voltage devices.

---

## Operation

When power is first applied, the switched output will be active until the PIR sensor has become stable – a period that can range from 10 to 60 seconds. After the PIR sensor is stable, the load will be switched off and will remain off until motion is detected. Adjust the Sensitivity, Time Delay and Ambient Light Level pots as desired.

### Sensitivity Adjustment

Potentiometer R8 sets the sensitivity to motion. Turning it towards + increases sensitivity; conversely, turning it towards – decreases sensitivity. By decreasing the sensitivity, however, detection distance is reduced. Conversely, the amount of motion required to trigger the output is increased.

### Time Delay Adjustment

The amount of time that the Switched Output (Relay) is turned on can be set by adjusting Time Delay potentiometer R1. Turn R1 toward + to increase the relay's on time; turn R1 toward – to decrease this on time. The delay time range is 2 seconds to 5 minutes.

### Ambient Light Level Adjustment

The ambient light gate level is set by potentiometer R3. Turn R3 toward – to decrease the ambient light level required before the output will be allowed to turn on. Turn R3 toward + to increase the ambient light level required before the output will be allowed to turn on.

## Electrical Specifications

The performance and electrical specifications for the ZMOTION AC Load Controller listed in Table 7 reflect all available data as a result of testing prior to qualification and characterization. As such, the data presented in the following specifications are subject to change.

Table 7. Electrical and Performance Specifications for the ZMOTION AC Load Controller

Parameter	Min.	Max.	Units	Notes
Input Voltage Range	108	240	Volts AC	
Switched Voltage	108	240	Volts AC	Same as AC input.
Switched Current	–	5	Amps	Fuse limited.
Time Delay	2 seconds	5 minutes	–	Adjustable.
Motion Sensitivity		Lens-dependent		Adjustable.
Ambient Light Threshold	1	100	Lux	Adjustable; range is typical.
Current Consumption		25	mA	120VAC input.
		44	mA	230VAC input.

► **Note:** Stresses greater than those listed in Table 7 may cause permanent damage to the ZMOTION AC Load Controller device. These ratings are stress ratings only. Operation of the device at any condition outside those indicated in the operational sections of these specifications is not implied. Exposure to absolute maximum rating conditions for extended periods affects device reliability.

## Mechanical Profile

Figures 10 through 12 show the dimensions, mounting hole, and sensor locations of the ZMOTION AC Load Controller reference design. All PCB layout files are available free for download in the [RD0028-SC01.zip](#) file.

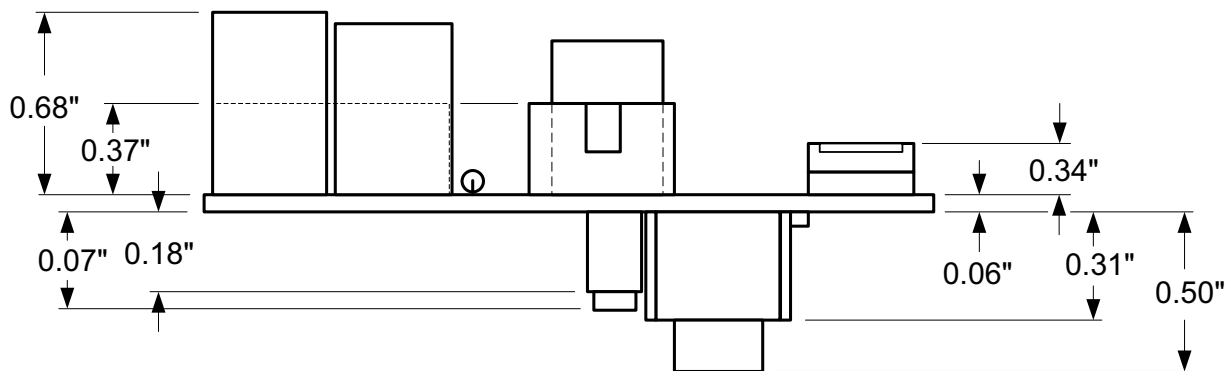

Figure 10. ZMOTION AC Load Controller, Side Profile

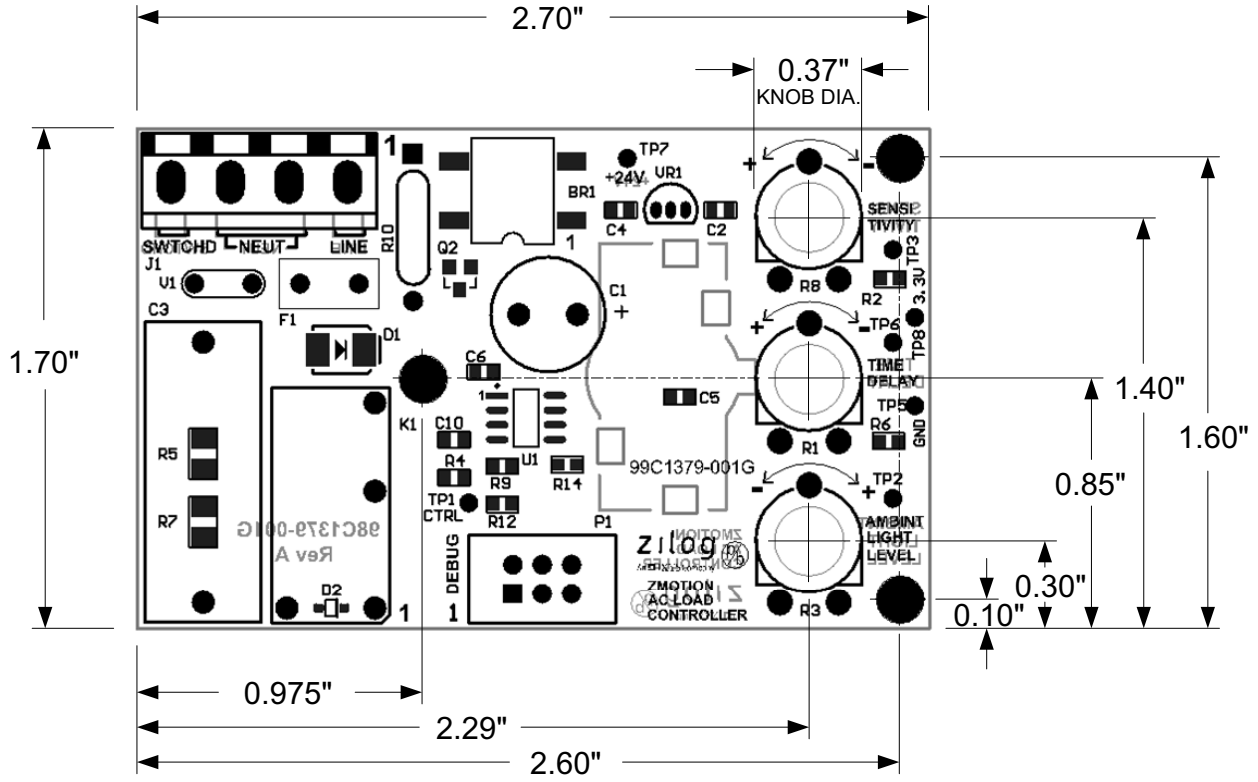

Figure 11. ZMOTION AC Load Controller, Component Side

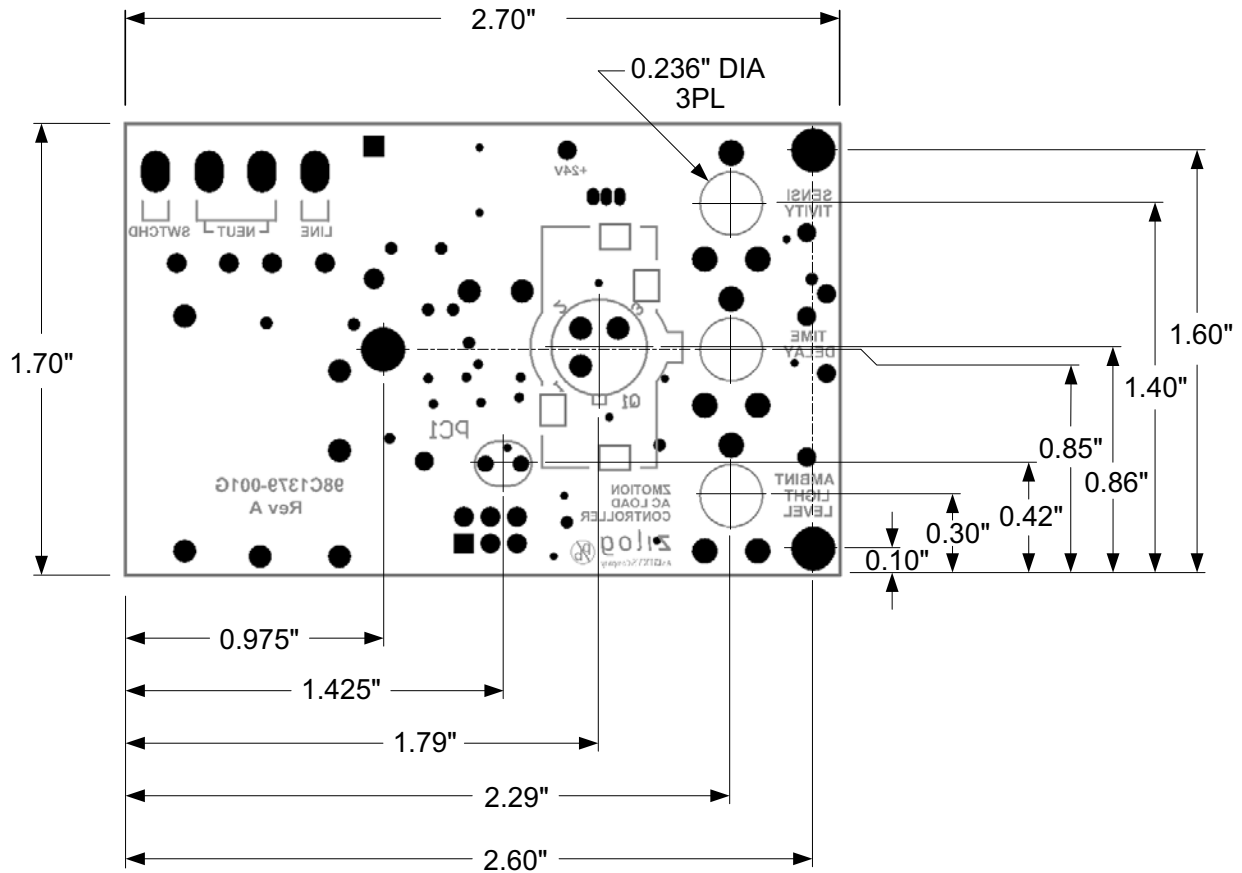

Figure 12. ZMOTION AC Load Controller, Sensor Side

## Kit Contents

The ZMOTION AC Load Controller Reference Design Kit contains the following items:

- ZMOTION AC Load Controller Module with ZNCL-10R lens
- USB SmartCable
- Additional lenses: ZNCL-9(26), NCL-10IL, ZNCL-3B, NCL-10S, ZNCL-11
- ZMOTION AC Load Controller Kit Insert Flyer

## Ordering Information

The ZMOTION AC Load Controller is available as an individual module and as part of a kit, as shown in the Kit Contents section that follows. Both products can be ordered from the [Zilog Store](#) using the part numbers listed in Table 8. When ordered as an individual module, the ZMOTION AC Load Controller ships with the ZNCL-10R lens installed.

**Table 8. Adaptive Persistence Display Ordering Information**

Part Number	Description	Product ID
<a href="#">ZMOTIONAC00ZR DG</a>	ZMOTION AC Load Controller Reference Design Module	<a href="#">RD10027</a>
<a href="#">ZMOTIONAC00KITG</a>	ZMOTION AC Load Controller Reference Design Kit	<a href="#">RD10028</a>

## Related Documentation

The documents associated with the ZMOTION AC Load Controller Reference Design are listed in Table 9. Each of these documents can be obtained from the Zilog website by clicking the link associated with its Document Number.

**Table 9. ZMOTION AC Load Controller Documentation**

Document Number	Description
<a href="#">RD0028</a>	This ZMOTION AC Load Controller Reference Design document
<a href="#">RD0028-SC01</a>	Source code and hardware design files that support this reference design
<a href="#">PS0285</a>	ZMOTION Detection & Control MCU Product Specification
<a href="#">PS0286</a>	ZMOTION Lens and Pyroelectric Sensor Specification
<a href="#">WP0018</a>	ZMOTION Lens & Pyro Configuration Guide
<a href="#">PS0228</a>	Z8 Encore! XP F082A Series Product Specification
<a href="#">UM0181</a>	USB SmartCable User Manual

## Results

See [Table 7](#) on page 21 to view the performance results for this reference design.

## Summary

This ZMOTION AC Load Controller reference design demonstrates how to use Zilog's ZMOTION MCU in a passive infrared-based motion detector to control power to an AC load. It can be used as a significant head start when adding motion detection capabilities to your own product. The software and hardware design files provided can be used as-is in an end application, or modified to meet specific design requirements. Either way, this reference design provides sufficient information and instruction to ensure a successful implementation.



## Appendix A. Schematic Diagrams

Figure 13 displays a schematic diagram of the ZMOTION AC Load Controller Reference Design.

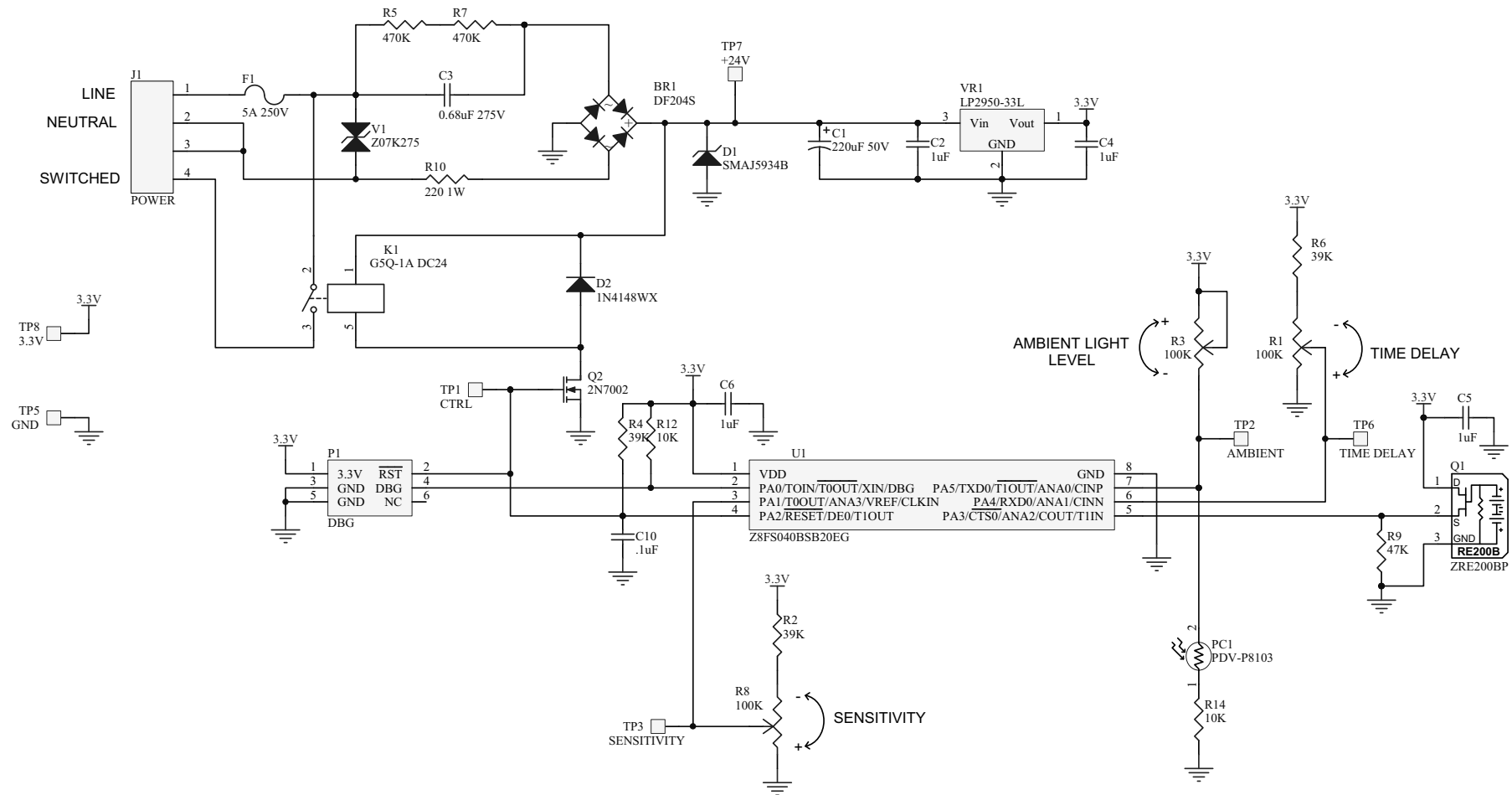

Figure 13. Schematic Diagram of the Persistence of Vision Application

## Appendix B. Bill Of Materials

Table 10 lists all parts that comprise the ZMOTION AC Load Controller Reference Design.

**Table 10. Parts List**

Item	Qty.	Description	Designator	Manufacturer	Mfg. Part Number
1	1	IC - Full Wave Bridge Rectifier 400V, 2A	BR1	Comchip	DF204S-G
2	1	Cap - Alum, 220 $\mu$ F, 50V, 20%	C1	Panasonic	ECA-1HHG221
3	4	Cap - Cer, 1 $\mu$ F 16V, Y5V	C2, C4, C5, C6	Murata	GRM188F51C105ZA01D
4	1	Cap - Film, 0.68 $\mu$ F, 275VAC, X2	C3	Panasonic	ECQ-UAAF684M
5	1	Cap Cer, 0.1 $\mu$ F, 25V, Y5V	C10	Murata	GRM188F51E104ZA01D
6	1	Diode - Zener, 1.5W, 24V	D1	Micro Commercial	SMAJ5934B-TP
7	1	Diode - 1N4148, 75V, 300mA	D2	Micro Commercial	1N4148WX-TP
8	1	Fuse - 5A, 250V	F1	Cooper Bussmann	SS-5H-5A-AP
9	1	Term Block - 4 Pos, 5mm	J1	Phoenix Contact	1729034
10	1	Relay - SPST, 277V,10A, 24V Coil	K1	Omron	G5Q-1A DC24
11	1	Conn - 6 Pin Header With Shell	P1	FCI	75869-131LF
12	1	CDS Photocell - 16-33KOHM	PC1	Advanced Photonix	PDV-P8103
13	1	Pyro Sensor - Dual Element, ZRE200B	Q1	Zilog	ZRE200B
14	1	FET - 60V, 200mA	Q2	ST Micro	2N7002
15	3	Potentiometer - 100K, 20%, Top/Bot Adj.	R1, R3, R8	CTS	262UR104B
16	3	Resistor - 39K, 5%	R2, R4, R6	Panasonic	ERJ-3EKF3902V
17	2	Resistor - 470K, 5%	R5, R7	Panasonic	ERJ-8ENF4703V
18	1	Resistor - 47K, 5%	R9	Panasonic	ERJ-3GEYJ473V
19	1	Resistor - 220, 5%, 1W, Mtl Ox, Flame Proof	R10	Panasonic	ERG-1SJ221
20	2	Resistor - 10K 5%	R12, R14	Yageo	RC0603FR-0710KL
21	1	IC - ZMOTION MCU 8 pin Lighting Engine	U1	Zilog	Z8FS040BSB20EG

Note: All components listed in red are supplied by Zilog.



Table 10. Parts List (Continued)

Item	Qty.	Description	Designator	Manufacturer	Mfg. Part Number
22	1	MOV - 275V, 21J, 7mm	V1	Epcos	S07K275
23	1	IC: Voltage Reg, LDO, 3.3V, 100mA, 2%	VR1	TI	LP2950-33LPR
24	1	Hardware: Perm-O-Pad Round, 1.5mm thick	Q1 Spacer	Bivar	514-060
25	1	Hardware: Infrared Lens	Q1 Lens	Various	Various
26	1	Hardware: CDS Spacer, 4.6mm	PC1 Spacer	Keystone	8903

Note: All components listed in red are supplied by Zilog.

---

## Customer Support

To share comments, get your technical questions answered, or report issues you may be experiencing with our products, please visit Zilog's Technical Support page at <http://support.zilog.com>.

To learn more about this product, find additional documentation, or to discover other facets about Zilog product offerings, please visit the Zilog Knowledge Base at <http://zilog.com/kb> or consider participating in the Zilog Forum at <http://zilog.com/forum>.

This publication is subject to replacement by a later edition. To determine whether a later edition exists, please visit the Zilog website at <http://www.zilog.com>.



**Warning:** DO NOT USE THIS PRODUCT IN LIFE SUPPORT SYSTEMS.

---

### LIFE SUPPORT POLICY

ZILOG'S PRODUCTS ARE NOT AUTHORIZED FOR USE AS CRITICAL COMPONENTS IN LIFE SUPPORT DEVICES OR SYSTEMS WITHOUT THE EXPRESS PRIOR WRITTEN APPROVAL OF THE PRESIDENT AND GENERAL COUNSEL OF ZILOG CORPORATION.

### As used herein

Life support devices or systems are devices which (a) are intended for surgical implant into the body, or (b) support or sustain life and whose failure to perform when properly used in accordance with instructions for use provided in the labeling can be reasonably expected to result in a significant injury to the user. A critical component is any component in a life support device or system whose failure to perform can be reasonably expected to cause the failure of the life support device or system or to affect its safety or effectiveness.

### Document Disclaimer

©2014 Zilog, Inc. All rights reserved. Information in this publication concerning the devices, applications, or technology described is intended to suggest possible uses and may be superseded. ZILOG, INC. DOES NOT ASSUME LIABILITY FOR OR PROVIDE A REPRESENTATION OF ACCURACY OF THE INFORMATION, DEVICES, OR TECHNOLOGY DESCRIBED IN THIS DOCUMENT. ZILOG ALSO DOES NOT ASSUME LIABILITY FOR INTELLECTUAL PROPERTY INFRINGEMENT RELATED IN ANY MANNER TO USE OF INFORMATION, DEVICES, OR TECHNOLOGY DESCRIBED HEREIN OR OTHERWISE. The information contained within this document has been verified according to the general principles of electrical and mechanical engineering.

Z8, Z8 Encore! and Z8 Encore! XP are trademarks or registered trademarks of Zilog, Inc. All other product or service names are the property of their respective owners.