

PART NUMBER	REV	FIRST USED
567952-1	C	854040-3

TERMINAL NAME: BLADE		286750	VISIBLE PAD LTR	CRIMP DATA (NON-AMP TERM-CUST SPEC)	
				CRIMP HEIGHT	WIRE SIZE
AMP P/N	MFG P/N			A	.053 ±.002 [1.35 ±0.05mm]
286750	LTP-1811-58AU			B	NOT USED
				C	NOT USED
				D	NOT USED
				CRIMP WIRE	SIZE TYPE RANGE
				.094	[2.39mm] F 20
				.110	[2.79mm] F 20
WIRE STRIP LENGTH	TERM APPL SPEC	FEED	APPL INSTRUCTION	SET UP GAGE	LAYOUT
.203-.218	NONE	.600	SEE CUSTOMER MANUAL	NONE	L2115

SIM TO HDM NONE					70
					69
					68
					67
					66
					65
					64
					63
					62
					61
					60
					59
					58
					57
REF	-	B	694433-8	PAWL, FEED	56
					55
					54
					53
					52
1	-	A	811242-2	BUMPER, HOLDDOWN	51
1	-	A	690753-1	SPACER, TONKER	50
					49
1	-	A	690602-6	CAM, PRE-FEED 1.62 STROKE	48
					47
					46
1	-	A	690191-1	PLUG, NYLON	45
1	-	C	819307-4	RAM	44
1	-	A	690125-1	WASHER, LAMINATED	43
1	-	A	690124-1	WASHER, RAM	42
1	-	A	7-21002-9	BOLT, CRIMPER (5/16x1.00)	41
1	-	A	23241-6	BALL, STEEL	40
1	-	A	690170-1	SPRING, COMPRESSION	39
1	-	C	690142-4	DISC, INSULATION	38
1	-	D	354777-1	WIRE DISC, PLASTIC	37
1	-	A	22480-5	WASHER, SPRING	36
1	-	B	690212-1	POST, RAM	35
1	-	B	690786-1	SUPPORT, TERMINAL	34
1	-	C	462544-1	PLATE, BASE SPECIAL	33
1	-	A	690432-3	SCREW, ADJUSTMENT	32
1	-	B	462543-1	BLOCK, SCREW SPECIAL	31
1	-	B	455689-1	BLOCK, STRIP GUIDE ADJ	30
1	-	C	458144-1	PLATE, STRIP GUIDE	29
1	-	C	1-455888-5	SPACER, FRONT SHEAR DEP	28
2	-	A	1-22284-0	SPRING, DRAG	27
1	-	B	240793-1	LEVER, DRAG RELEASE	26
1	-	B	240792-1	DRAG, TERMINAL	25
1	-	D	90765-4	GUIDE, STRIP (REAR)	24
1	-	A	690438-1	GUIDE, STRIP (FRONT)	23
					22
1	-	A	463756-1	GUIDE, SCRAP	21
					20
1	-	C	904458-1	STRIPPER	19
1	-	B	904225-1	JAW ASSY	18
					17
					16
					15
					14
					13
1	-	A	5-22280-0	SPRING, SHEAR	12
1	-	B	1-690461-6	STOP, SHEAR (FRONT)	11
1	-	B	462548-1	HOLDER, SHEAR (FRONT) SP	10
1	-	B	462547-2	SHEAR, FLOAT (FRONT) SP	9
1	-	C	2-662520-3	ANVIL	8
1	-	C	240641-1	SPACER, DEPRESSOR (REAR)	7
					6
1	-	A	462838-1	DEPRESSOR, SHEAR (FRONT) SP	5
1	-	B	238011-2	SPACER, BLOCK CRIMPER	4
1	-	C	1-456134-5	CRIMPER, INSULATION	3
1	-	C	455888-5	SPACER, CRIMPER	2
1	-	C	1-568176-1	CRIMPER, WIRE	1

2	-	C	3-354779-6	PIN, WIRE DISC (.3170)C	129
					128
					127
					126
1	-	A	986950-1	WASHER, FLAT PRECISION	125
1	-	A	217238-3	GENERAL INSTRUCTION PACKAGE	124
					123
					122
1	-	A	4-21028-0	PIN, SLT SPR (Ø.093x.75) ST 60E PL	121
1	-	B	690701-2	PLATE, SERIAL NO.	120
2	-	A	21899-2	WASHER, FLAT (#10) 5 G ADJ BLK	119
					118
2	-	A	21024-5	WASHER, LOCK (#10) ADJ BLOCK	117
					116
					115
2	-	A	21024-2	WASHER, LOCK (#4) FRONT STP GUIDE	114
REF	-	A	21024-4	WASHER, LOCK (#8) FEED FINGER	113
2	-	A	21024-4	WASHER, LOCK (#8) DEP-HOLD	112
REF	-	A	21024-4	WASHER, LOCK (#8) STRIPPER	111
					110
					109
1	-	A	21018-5	NUT, HEX (#6) HOLD DOWN	108
					107
					106
1	-	A	22353-8	SCR, SHLD (Ø.187x.25) DRAG LEVER	105
					104
1	-	A	21009-2	SCR, SKT 5ET (1/4-20x.25 LW) RAM	103
					102
4	-	A	21017-2	SCR, DRIVE (#2x.19) ID PLATE	101
1	-	B	819347-1	PLATE, IDENTIFICATION	100
2	-	A	3-21002-0	SCR, BHC (10-32x.88) DRAG	99
1	-	A	22733-8	SCR, BHC (8-32x.38 LW) ANVIL	98
					97
1	-	A	3-21000-8	SCR, SHC (10-32x.88) MOUNTING	96
1	-	A	2-21002-7	SCR, BHC (10-32x.50) 5G ADJ BLK	95
6	-	A	2-21002-2	SCR, BHC (8-32x.50) SHEAR-TERM SUP	94
					93
					92
1	-	A	1-21002-7	SCR, SHC (6-32x.50) CAM	91
2	-	A	2-21000-7	SCR, SHC (8-32x.50) SCR BLK	90
2	-	A	2-21000-9	SCR, SHC (8-32x.75) HLD DWN	89
					88
					87
REF	-	A	2-22603-0	SCR, HEX HD (8-32x.31) FEED FINGER	86
2	-	A	1-21000-3	SCR, SHC (4-40x.25) F ST GUIDE	85
REF	-	A	22733-9	SCR, BHC (8-32x.50 SL) STRIPPER	84
					83
					82
1	-	A	3-22603-1	SCR, HEX (10-32x.38) 5G ADJ BL	81
					80
					79
					78
2	-	B	463310-5	BLADE, STRIPPING (#20)	77
					76
					75
1	-	A	690603-1	SPRING, ASSIST	74
1	-	A	23030-1	SCR, SKT CAP (6-32x.25) CP DSC	73
					72
					71

QTY	REQD PER ASSY	U/M	DWG SIZE	PART NO	DESCRIPTION	ITEM NO
-----	---------------	-----	----------	---------	-------------	---------

PARTS LIST		REVISION RECORD	
C1	ECN 0150-0458-04	TE	4-04
B	0150-9584-99	TE	SEP99
C	0150-9448-99	DS	7-99
A1	0150-9352-99	PM	5-99
A	REVISED	CE	10/98

QTY	REQD PER ASSY	U/M	DWG SIZE	PART NO	DESCRIPTION	ITEM NO
-----	---------------	-----	----------	---------	-------------	---------

PARTS LIST		REVISION OF EACH ASSY NO (WHEN BLANK, USE DWG REVISION)	
DR	01SEP98	APP	01SEP98
B.HIGMAN		T.ELBIN	
CHK	01SEP98	REL	
C.ERISMAN			
NAME		MACHINE REF	
STRIPPER CRIMPER APPLICATOR		STRIPPER CRIMPER	
SCALE	DWG NO	567952	SHEET 1 OF 1
REV	C1		

THIS DRAWING IS A CONTROLLED DOCUMENT.

RELEASED FOR PUBLICATION JUL 22, 1998 BY AMP INCORPORATED. ALL RIGHTS RESERVED.

LOC A
DIST 66

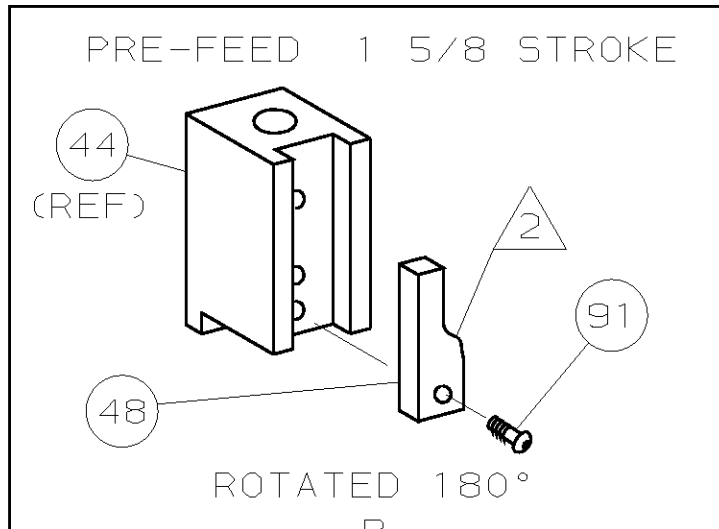
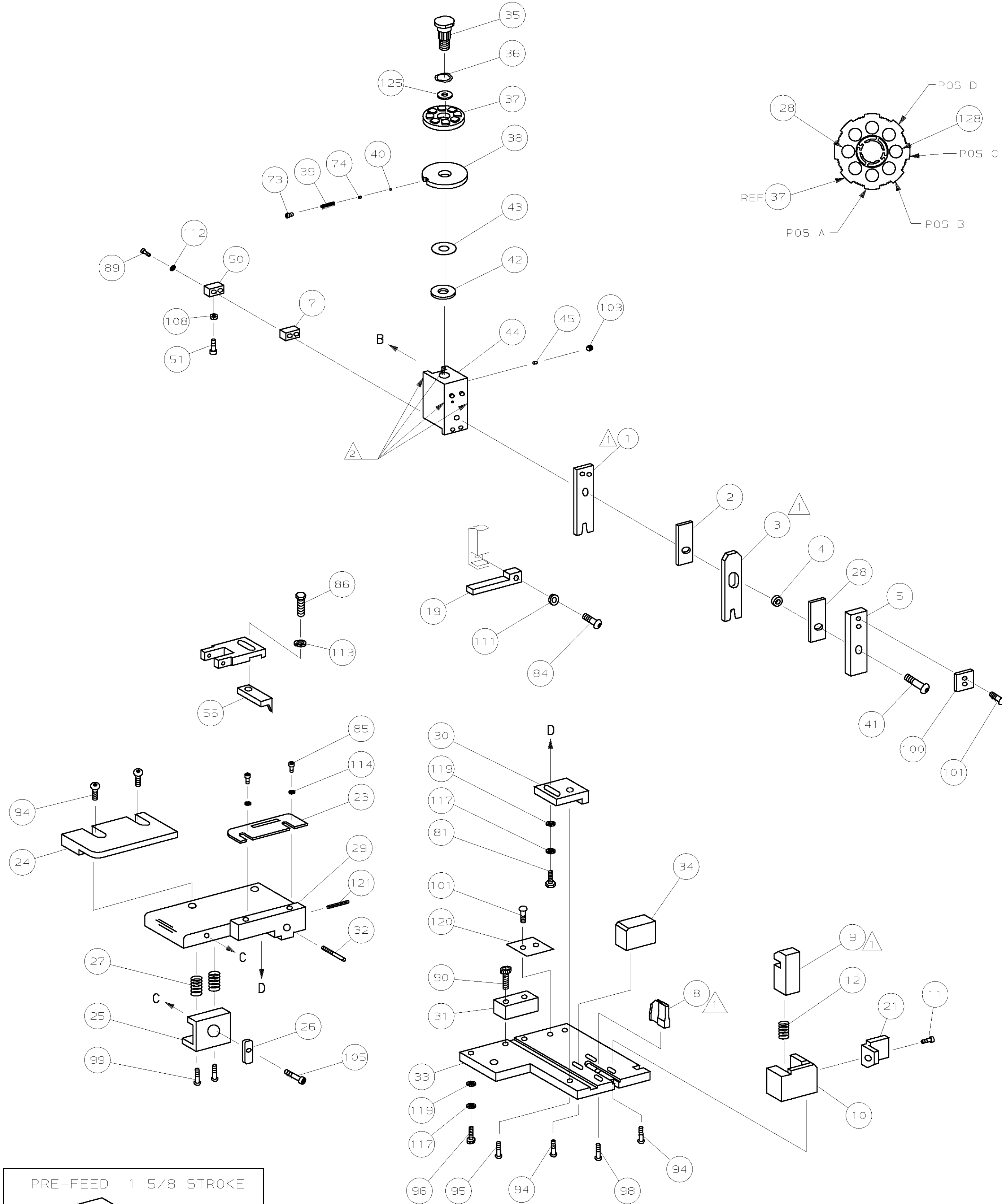

- 1 RECOMMENDED SPARE PARTS.
 - 2 GREASE LIGHTLY.
 - 3 ITEM NOT SHOWN
 - 4 INS RANGE TO BE DETERMINED AT SET-UP.
 - 5 CUT TO LENGTH AT ASSEMBLY.
6. ON THE STRIPPER CRIMPER MACHINE, POSITION THE FRONT METAL GUARD ON THE FRONT SIDE OF THE LEXAN DOOR

DIMENSIONS IN INCHES. DO NOT SCALE PRINT. TOLERANCES UNLESS OTHERWISE SPECIFIED:
 2 PLC DEC ±
 3 PLC DEC ±
 4 PLC DEC ±
 ANGLES ±
 SURF TEXTURE: ✓
 REMOVE BURRS, BREAK SHARP EDGES R.015 MAX