

THIS DRAWING IS UNPUBLISHED. RELEASED FOR PUBLICATION, 19
 © COPYRIGHT 19 BY AMP INCORPORATED. ALL INTERNATIONAL RIGHTS RESERVED.

LOC	DIST	P	F	ZONE	LTR	REVISIONS	DATE	APPD
AF	50				J	0BS -3 PER 0710-0246-96	6/12/96	JR/PD

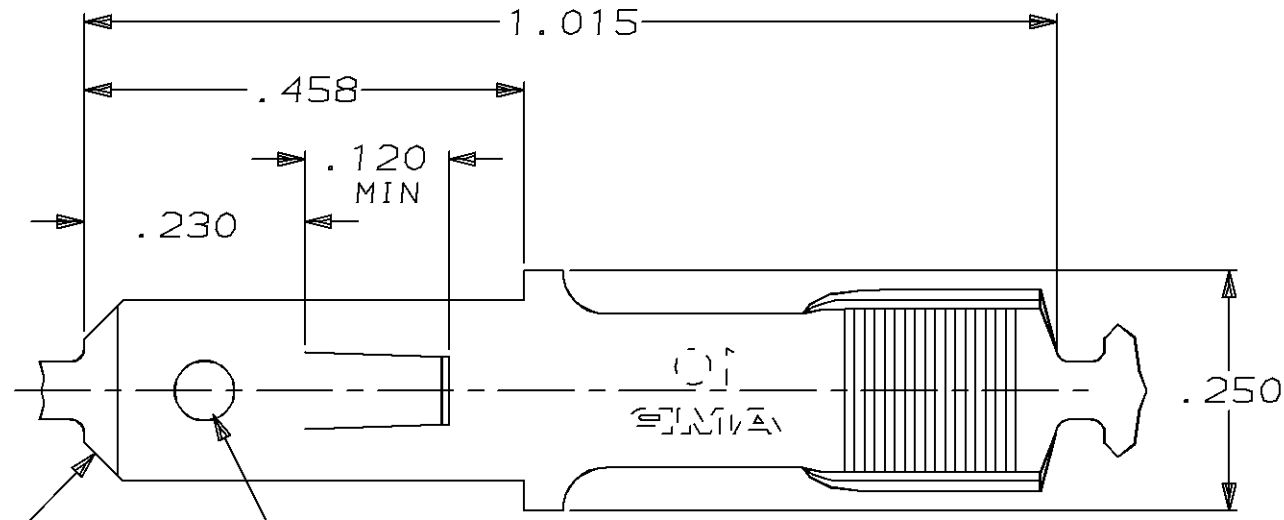

- 1 CONTINUOUS STRIP ON REELS
- 2 REVERSE REELING FROM 62443-2.

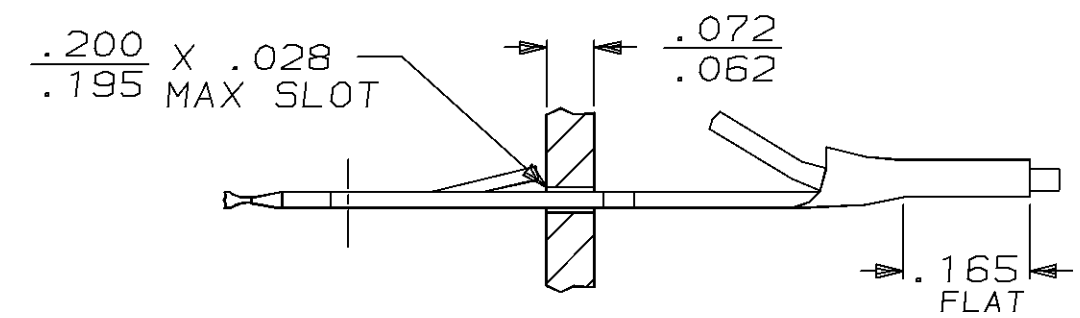

INSTALLED VIEW
PIGTAIL CRIMP

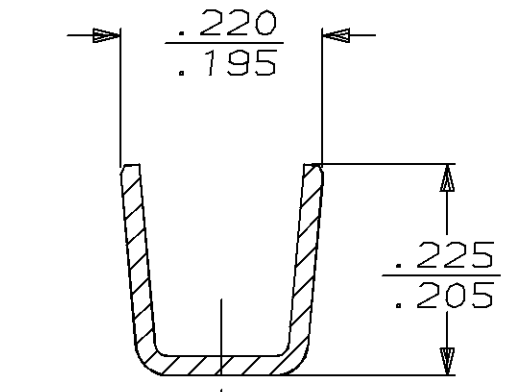
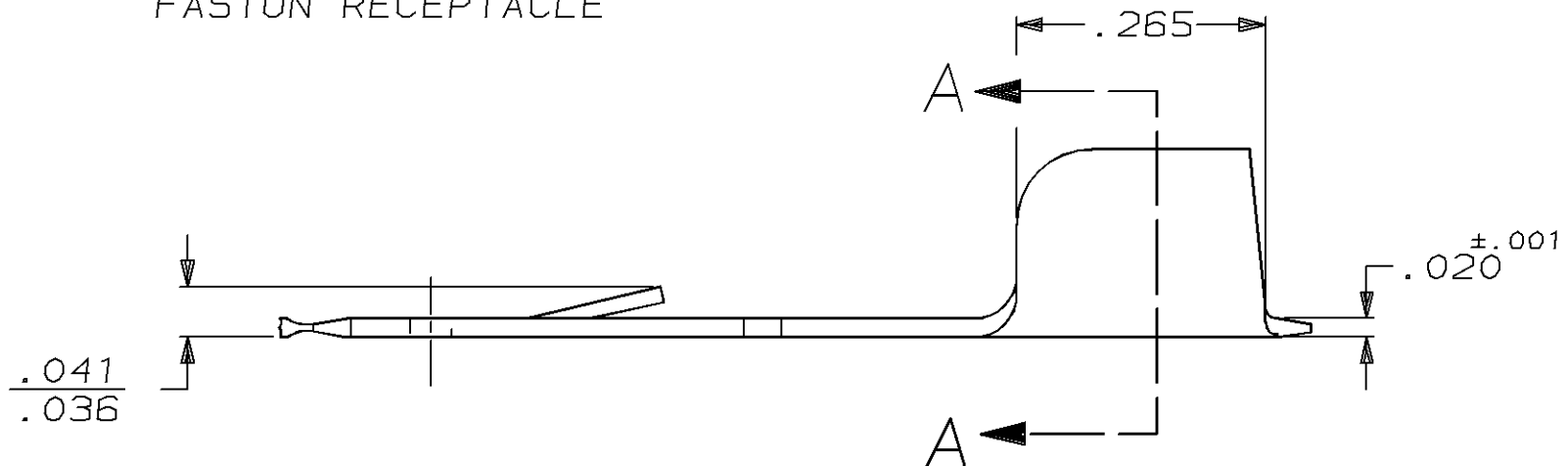

SECTION A-A

#12-10 MAGNET WIRE 7000 - 13000 CMA	TIN / VARNISH RESIST	62443-3
	TIN .000080 MIN	62443-2
		62443-1

WIRE SIZE	FINISH	PART NO
DO NOT SCALE PRINT. UNLESS SPECIFIED DIMENSIONS ARE IN INCHES. TOLERANCES ON: 2 PLC DEC ± - 3 PLC DEC ± .015 ANGLES ± -	DR 2/19/92 JR RUTH CHK 2/19/92 MS FEHER APPD 2/19/92 J GILLESPIE APPD 2/19/92 D REINER PRODUCT SPEC -	AMP AMP Incorporated Harrisburg, PA 17105-3608
MATERIAL H02 BRASS	APPLICATION SPEC -	NAME TAB, AMPLIVAR, FASTIN-FASTON, .187 SERIES
FINISH SEE TABLE	WEIGHT -	SIZE B CAGE CODE 00779 DRAWING NO 62443
		SCALE 5:1 SHEET 1 OF 1