

THIS DRAWING IS UNPUBLISHED. RELEASED FOR PUBLICATION 20
 © COPYRIGHT 20 BY - ALL RIGHTS RESERVED.

REVISIONS					
P	LTR	DESCRIPTION	DATE	DWN	APVD
-	AI	PER ECR-14-008896	16JUN2014	BL	JY

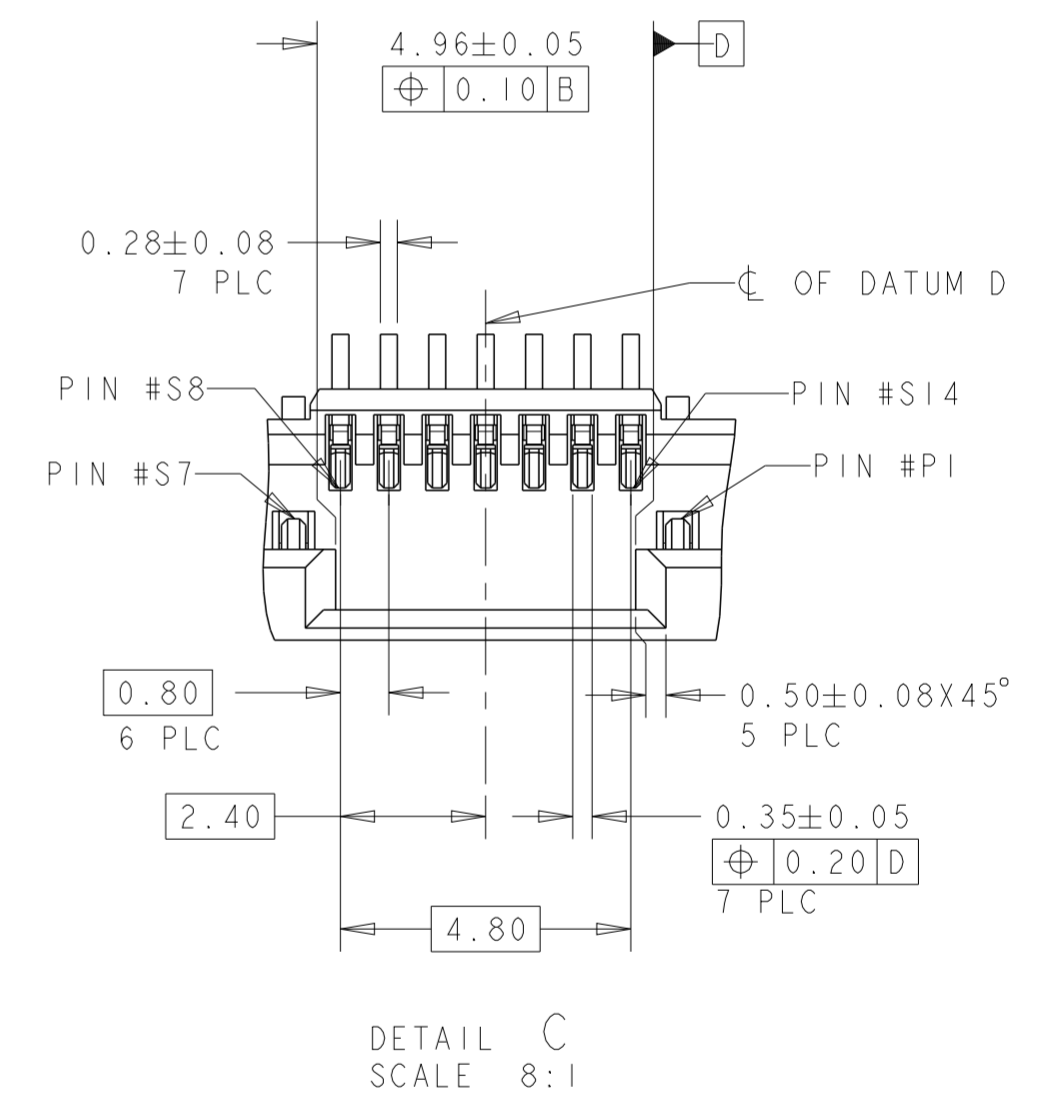
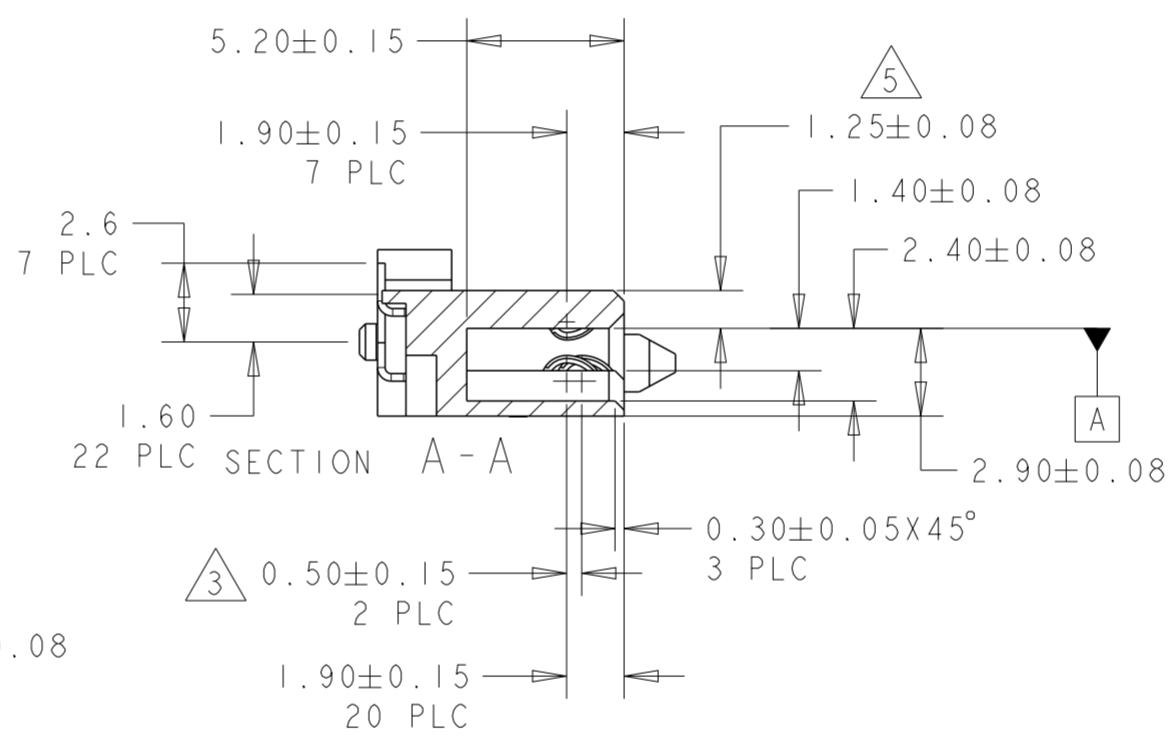
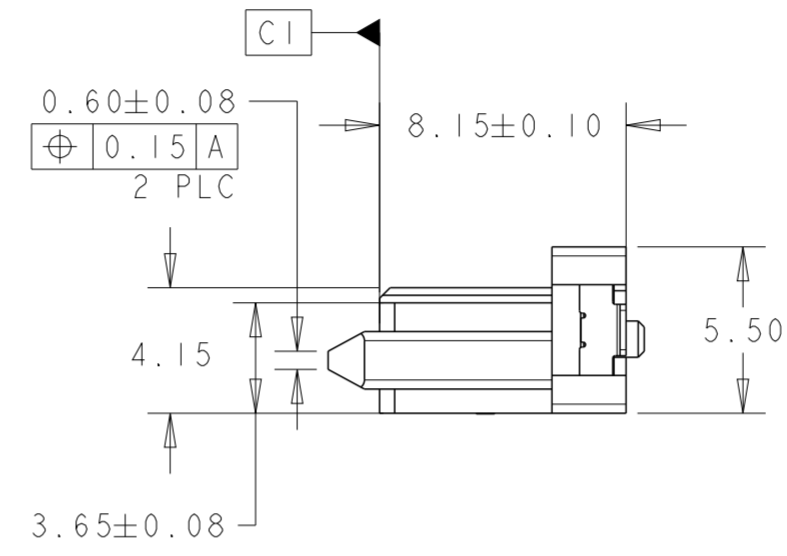
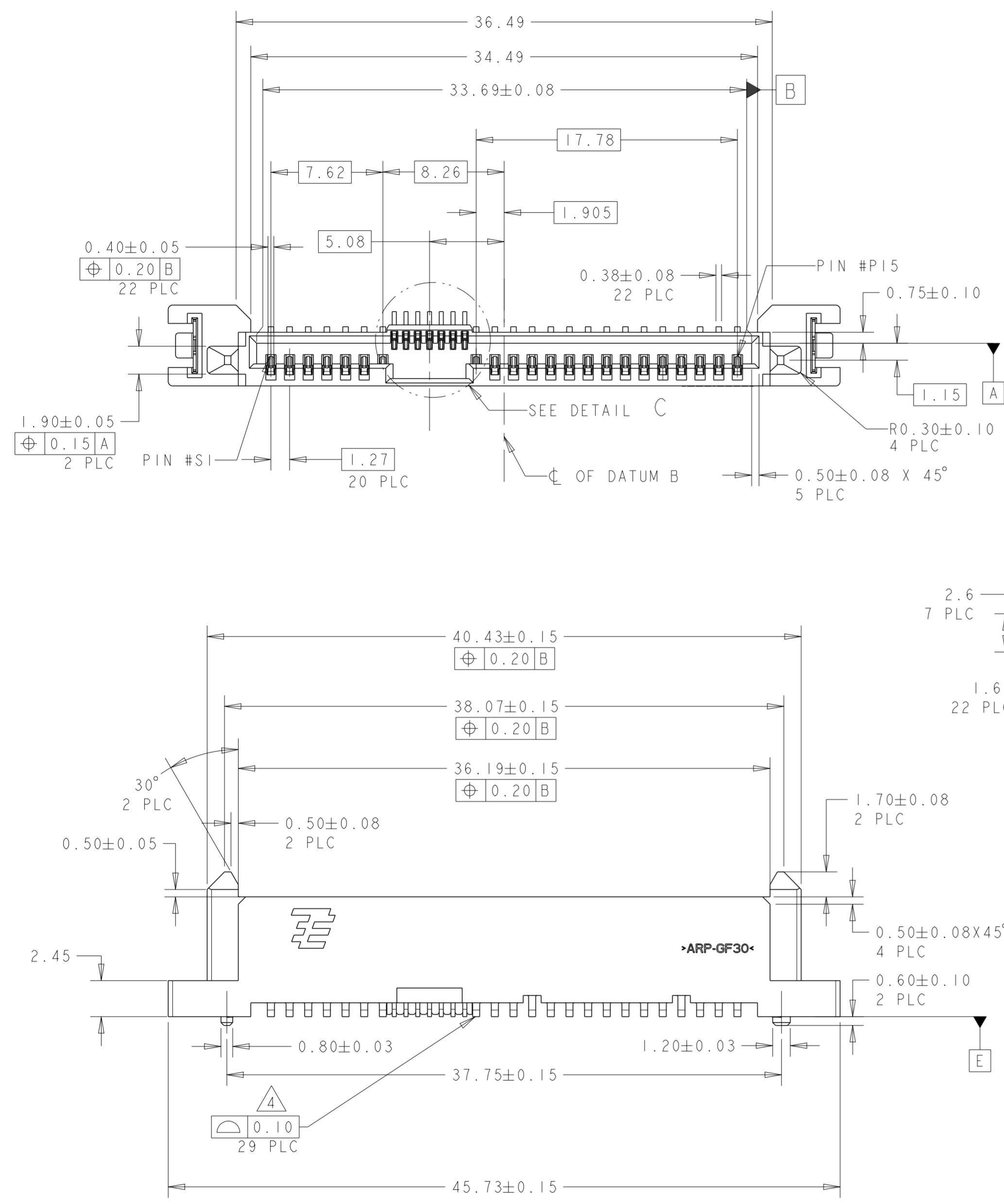

NOTES:

- 1 MATERIAL:
HOUSING: HIGH TEMP THERMOPLASTIC, UL94V-0,
COLOR: BLACK
CONTACT: COPPER ALLOY
- 2 FINISH:
CONTACT AREA: MIN 0.76um GOLD PLATING
SOLDERTAIL: MIN 2.54um MATTE TIN PLATING
UNDERPLATE: MIN 1.27um NICKEL PLATING
- 3 PIN #P4 AND #P12 ONLY
- 4 SOLDERTAIL TO BE 0.05 MAX ABOVE AND
0.10 MAX BELOW DATUM E
- 5 1.33 MAX MEASURED AT DATUM C

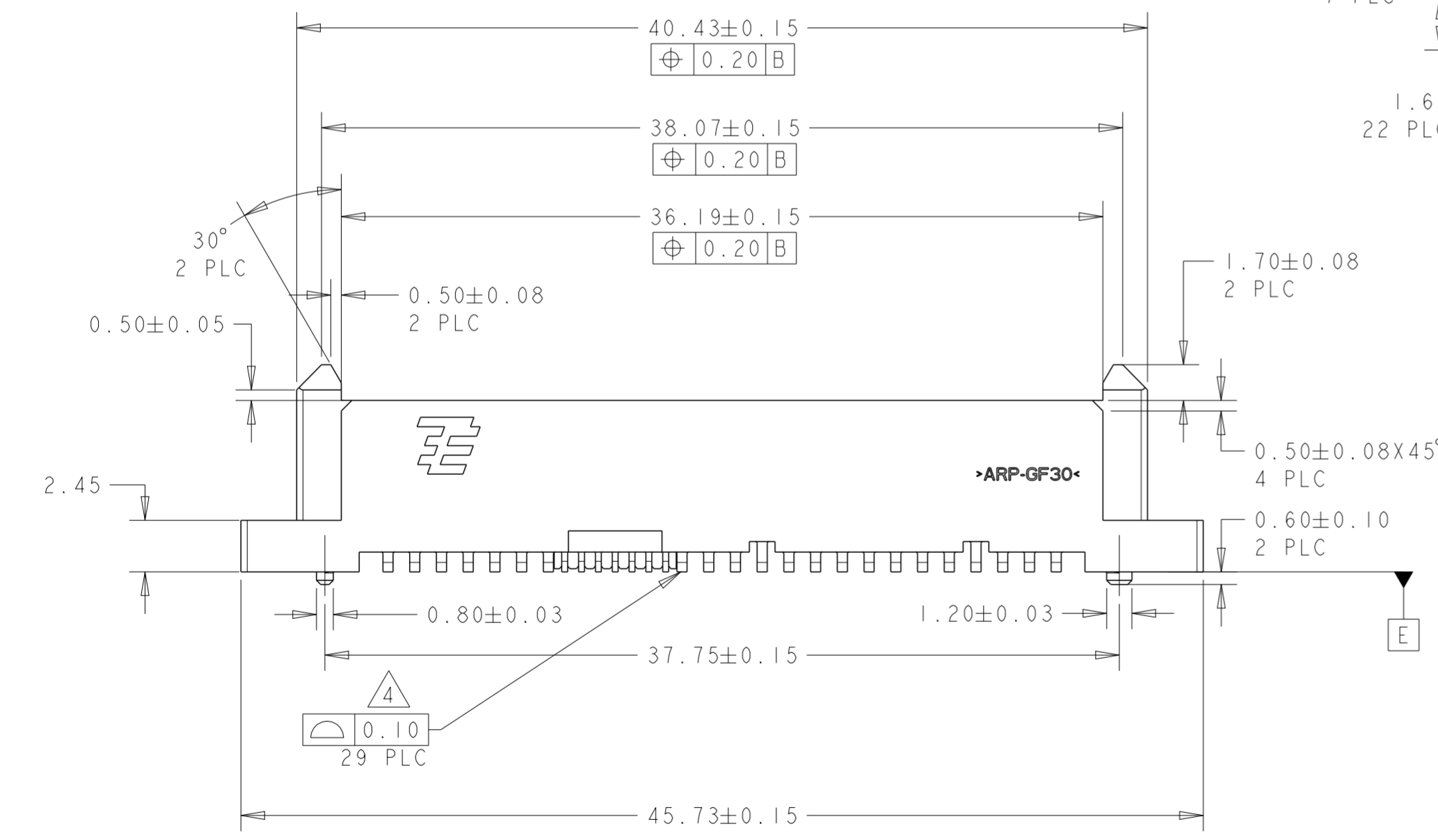

P/N: 1735870-1 AS SHOWN

THIS DRAWING IS A CONTROLLED DOCUMENT.		DWN TY PANG 15MAR2011	TE Connectivity		
DIMENSIONS: mm		CHK SF LEONG 15MAR2011			
TOLERANCES UNLESS OTHERWISE SPECIFIED:		APVD SF LEONG 15MAR2011	NAME SAS BACKPLANE RECEPTACLE, VERTICAL, SMT, SMT SOLDER PEG		
 0 PLC ± 1 PLC ± 2 PLC ±0.20 3 PLC ± 4 PLC ± ANGLES ±3° FINISH		PRODUCT SPEC 108-51067	DRAWING NO C-1735870		
MATERIAL 1		APPLICATION SPEC -	SIZE A2	CAGE CODE -	RESTRICTED TO -
		WEIGHT -	SCALE 4:1	SHEET 1 OF 2	REV A1
CUSTOMER DRAWING					

