

SPECIFICATIONS

PARAMETERS	VALUES	UNITS
RATED VOLTAGE	24	Vdc
OPERATING VOLTAGE RANGE	9 ~ 28	Vdc
TONE OUTPUT	SEE 32 TONE CHART	-
CURRENT CONSUMPTION (NOMINAL)	SEE 32 TONE CHART	mA
INGRESS PROTECTION	IP65	-
CASE MATERIAL/COLOR	ABS/RED	-
TERMINAL	LEAD WIRE	-
OPERATING TEMPERATURE	-10 ~ +60	°C
WEIGHT	95	grams

THIS DOCUMENT CONTAINS DATA PROPRIETARY TO PROJECTS UNLIMITED, INC. ANY USE OR REPRODUCTION, IN ANY FORM, WITHOUT PRIOR WRITTEN PERMISSION OF PROJECTS UNLIMITED, INC. IS PROHIBITED.
©2003, Projects Unlimited Inc.

REVISION HISTORY

LTR	DESCRIPTION	DATE	APPROVED
-	RELEASED FROM ENGINEERING	12/21/2005	
A	ADDED VOLUME CONTROL & TONE SWITCHES	12/19/2006	R.W.
B	REVISED LEAD WIRE DIMENSIONS	12/20/2006	R.W.
C	ADDED RoHS NOTE	5/21/2007	R.W.
D	REVISED DETAIL "A" DIL SWITCH	3/11/2009	B.R.
E	REVISED TO INVENTOR 3-D DRAWING TEMPLATE	5/20/2010	B.R.

DETAIL "A"

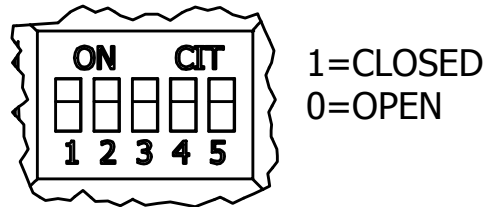

DETAIL "B" VOLUME CONTROL

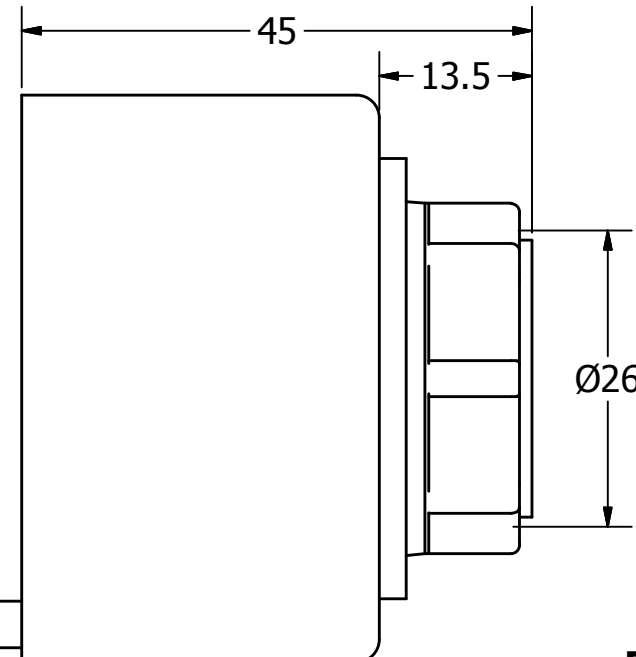
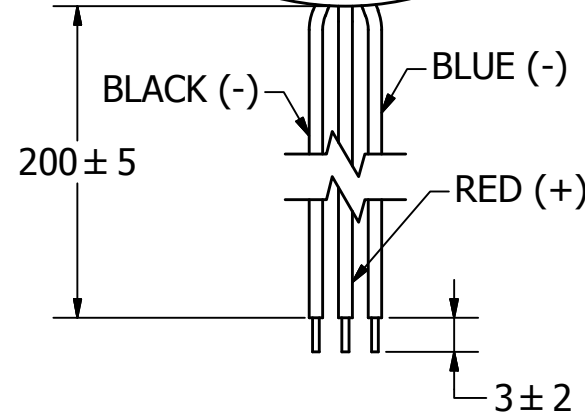
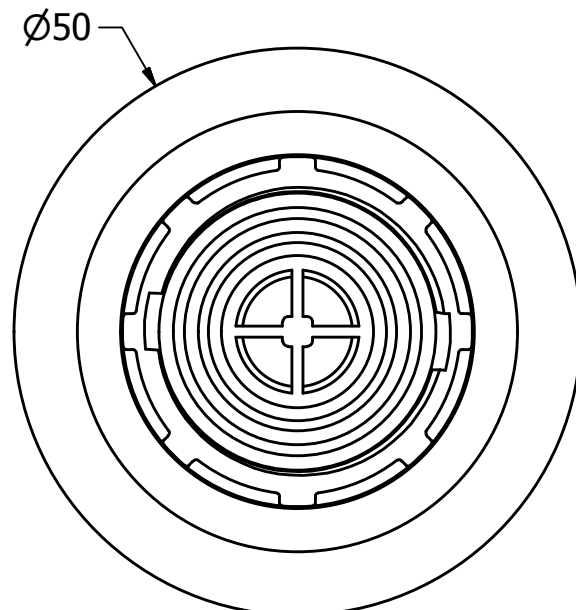
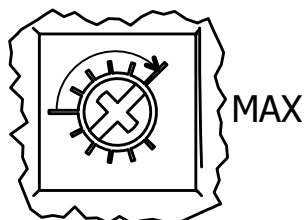

DETAIL "A"

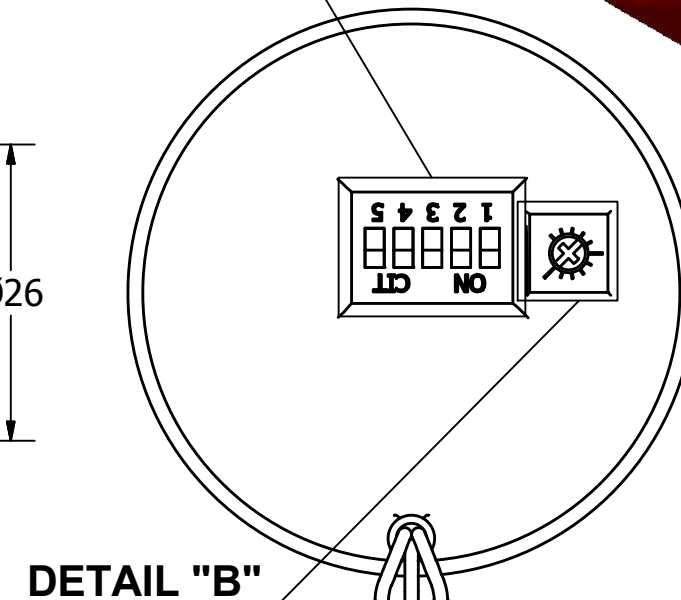

DETAIL "B"

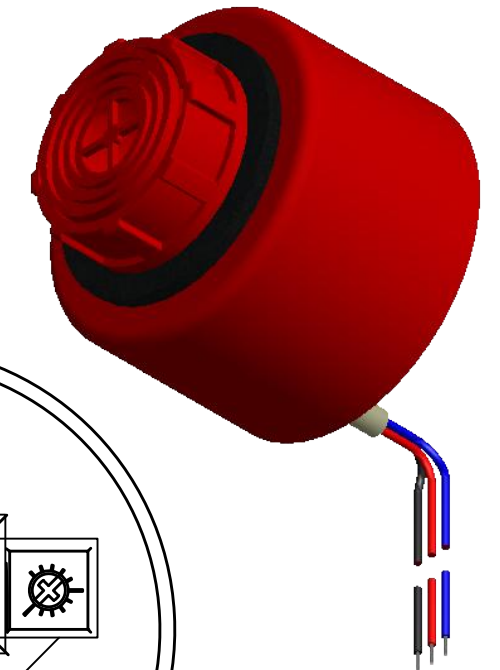
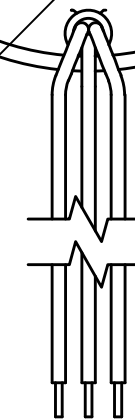

NOTES:

1. ALL DIMENSIONS ARE IN MILLIMETERS.
2. SPECIFICATIONS SUBJECT TO CHANGE OR WITHDRAWL WITHOUT NOTICE.
3. THIS PART IS RoHS 2002/95/EC COMPLIANT.

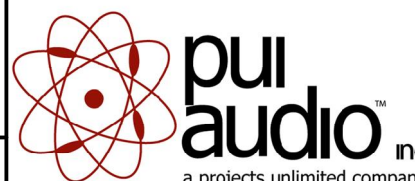
UNLESS OTHERWISE SPECIFIED: DIMENSIONS ARE IN MILLIMETERS, TOLERANCES ARE ±0.5 AND ANGLES ARE ±3°.	SIZE A3	Designed by	Date	Checked by	Date	Approved by	Date	Drawn Date
		J.A.F.	12/21/2005	E.P.	12/21/2005	B.R.	12/21/2005	5/20/2010
AW-10PR.idw				AW-10PR				
		Siren			Edition		Sheet	
					-		1 / 1	