

ATLANTIC VERSION TERMINATOR INTERFACE ADAPTER	PART NUMBER	REVISION	DESCRIPTION	FEED TYPE	APPLICATOR STYLE CONVERSION CHART						
					CONVERT TO	PART NUMBERS REQUIRED					
	2151818-2	G	FINE CRIMP HEIGHT ADJUST	PNEUMATIC	-	-	1338685-1	5-18022-5	-	-	-
	2151818-5	G	FINE CRIMP HEIGHT ADJUST	SERVO LATCH PLATE <sup>4</sup>	SERVO LATCH PLATE	2119951-1	-	8-2151818-5	1901094-3	-	2168400-6 (QUANTITY 2)
					SMART APPLICATOR	2161326-1	-	8-2151818-4	-	-	
	2151818-6	G	NON-CRIMP HEIGHT ADJUST	SERVO LATCH PLATE <sup>4</sup>	PNEUMATIC FEED	2119950-1	1338685-1	5-18022-5	2119641-1	2119799-1	2063440-1
					-	-	-	-	-	-	
	2151818-7	G	FINE CRIMP HEIGHT ADJUST	NONE	-	-	-	-	-	-	-
	7-2151818-7	A	CRIMP TOOLING KIT	-	-	-	-	-	-	-	-

APPLICATOR DATA		
CRIMP SIZE	TYPE	
WIRE 4.06 mm [.160]	F	
INSUL 4.83 mm [.190]	F	

APPLICATOR INSTRUCTIONS 408-10389

TERMINAL DATA: TE TERMINAL		TE CRIMP SPECIFICATION	
TERMINAL NAME: SPT LITEALUM CONTACT			
WIRE STRIP LENGTH		INSULATION DIAMETER RANGE	
3.90-4.50 mm [.154-.177 IN]		Ø4.13-4.38 mm [.163-.172 IN]	
TERMINAL APPLICATION SPECIFICATION	114-94204		
TERMINALS APPLIED <sup>9</sup>			
TE TERMINAL	TE TERMINAL	TE TERMINAL	TE TERMINAL
2-1862004-1			

WIRE SIZE	CRIMP HEIGHT mm [INCH]	CRIMP HEIGHT REFERENCE SETTING
6.00mm <sup>2</sup>	2.10±0.04 [.0827±.0016]	7.8

- <sup>1</sup> RECOMMENDED SPARE PARTS
- <sup>2</sup> GREASE BEARING SURFACES LIGHTLY
- 3. LUBRICATE DAILY PER THE APPLICATOR INSTRUCTION SHEET SUPPLIED WITH THE APPLICATOR.
- <sup>4</sup> APPLICATOR SPECIFIC DATA TO BE ENTERED INTO BLANK MEMORY CHIP AT ASSEMBLY. SEE BELOW FOR PART NUMBER:  
 PNEUMATIC FEED WITH "SMART APPLICATOR" CONVERSION: 8-2151818-4  
 SERVO FEED WITH "FINE CRIMP HEIGHT ADJUST": 8-2151818-5  
 SERVO FEED WITH "NON-CRIMP HEIGHT ADJUST": 8-2151818-6
- 5. ADJUSTMENT OF THE STRIPPER MAY BE REQUIRED WHEN MOVING THE APPLICATOR BETWEEN BENCH AND LEADMAKER APPLICATIONS.
- <sup>6</sup> APPLY PART NUMBER 1-23419-5 LOCTITE TO THREADS OF ITEMS 62. APPLY PART NUMBER 2-23419-6 LOCTITE TO THREADS OF ITEMS 99 & 242. FOR -6 ONLY APPLY PART NUMBER 1-23419-5 LOCTITE TO THREADS OF ITEMS 37.
- <sup>7</sup> MAGNET, ITEM 166 MUST BE ORIENTED CORRECTLY IN ORDER TO PROPERLY ACTUATE THE COUNTER.
- <sup>8</sup> CRIMP HEIGHT REFERENCE SETTING WAS THE SETTING USED WHEN THE APPLICATOR WAS QUALIFIED AT THE FACTORY. ADJUSTMENT MAY BE NECESSARY WHEN RUNNING APPLICATOR IN THE FIELD.
- <sup>9</sup> TERMINAL PITCH NOT COMPATIBLE WITH MECHANICAL FEED.
- <sup>10</sup> TO CONVERT THE APPLICATOR TO A NON-CARRIER CUTTING STYLE, REMOVE ITEM 13 AND ATTACH TO THE LOCATION ON THE BACK SIDE OF THE HOUSING. REFER TO INSTRUCTION SHEET FOR ADDITIONAL INFORMATION.
- <sup>11</sup> WHEN ASSEMBLING -6 NON-CRIMP HEIGHT ADJUST APPLICATOR USE SHIM PACK 2119957-2 TO ALIGN APPLICATOR'S MAXIMUM WIRE CRIMP HEIGHT AT NORMAL TERMINATOR SHUT HEIGHT
- <sup>12</sup> GREASE THREADS, GROOVE AND O-RING ON ITEMS 35 & 252.
- <sup>13</sup> SET THE FINE CRIMP HEIGHT ADJUSTMENT HEAD TO PROPER CRIMP HEIGHT PRIOR TO TIGHTENING/LOCKING THE BRASS TIP SET SCREW, ITEM 99, AGAINST THE ADJUSTMENT BOLT THREADS.
- 14. APPLICATOR TO BE USED IN CONJUNCTION WITH LEADMAKER INTIGRATION KIT, P/N 2280475-1 FOR CLAMPING AND SENSING OF FEED TRACK.

**\*WARNING**  
 ON INSTALLATION, SET WIRE DISC, ITEM 40 TO LARGEST WIRE SIZE SETTING. USE OF SETTINGS BELOW MINIMUM REQUIRED CRIMP HEIGHT SETTING WILL CAUSE DAMAGE TO CRIMP TOOLING.

-	1	1	1	1	2-1722335-1	THREAD BOLT GEWINDEBOLZEN	268
-	-	1	-	-	2119957-2	APPLICATOR SHIM PACK	260
-	1	-	1	1	8-21084-0	O-RING, .676 ID, .070 DIA. MAT.	252
-	-	-	-	1	2119640-1	PUSH ROD, AIR FEED	250
-	-	-	-	1	2079988-1	BUSHING, LCH5-12, MISUMI	249
-	-	-	-	1	2119641-1	FEED CAM, AIR FEED	248
-	1	-	1	1	2119798-1	DETENT PIN	247
-	1	-	1	1	1-22279-3	SPRING, COMPRESSION	246
-77	-7	-6	-5	-2	PART NO	DESCRIPTION	ITEM NO

**ATLANTIC VERSION**  
 Shown on sheets 1 of 4 & 2 of 4  
 (Pacific version shown on sheets 3 of 4 & 4 of 4)

SET UP GAUGE		LOC	DIST	REVISIONS			
2119599-1		A	66	REV	DATE	BY	CHKD
E	ECR-16-000265				07JAN2016	MR	JDG
F	ECR-16-003220				02MAR2016	JH	CT
G	ECR-16-013606				23SEP2016	JH	CT

-	-	1	-	-	2119758-1	RAM, AMP STYLE, SIDE FEED, NON-ADJ.	245
-	1	1	1	1	2119082-3	CAM, SNAIL, INSULATION ADJUSTMENT	244
-	1	1	1	1	2079764-1	WASHER, WAVE SPRING, CREST-TO-CREST	243
-	1	1	1	1	2119083-1	RETAINER, INSULATION DIAL	242
-	1	1	1	1	7-18023-7	SCR, SKT HD CAP M3 X 4.0	241
-	-	2	2	-	2168400-6	SHCS, LOW HEAD, RoHS, M5 X 16	240
-	-	-	-	1	2063440-1	AIR FEED MODULE	238
-	-	1	1	-	2119740-2	TAG, IDENTIFICATION	213
-	-	1	1	-	1901094-3	SPACER, FEEDER	198
-	-	-	-	2	21045-3	RING, RETAIN, EXTERN, 3/16 CRESCENT	172
-	1	1	1	1	994969-1	MAGNET, RARE EARTH HIGH ENERGY	166
-	REF	REF	REF	REF	994970-2	COUNTER, MAGNETIC	164
-	-	-	-	1	240638-1	SPRING, FEED FINGER	163
-	-	-	-	1	3-23627-7	PIN, RETAIN, GRVD, 3/16 X .854	137
-	-	-	-	1	2119799-1	HOLDER, FEED FINGER, AF	136
-	-	REF	REF	-	SEE NOTE 4	MEMORY CHIP, PROGRAMMED	135
-	-	1	1	-	1633743-1	SERVO FEED LATCH ASM	133
-	1	1	1	1	1-22281-8	SPRING, COMPRESSION	121
-	1	1	1	1	1-18028-2	WASHER, FLAT, REG M4	119
-	1	1	1	1	2256587-1	SCR, SET, SOFT TIP, M4	99
-	1	1	1	1	1-690438-0	FRONT STRIP GUIDE	96
-	2	2	2	2	2168083-1	SCR, SKT HD CAP, RoHS, M3 X 8.0	95
-	1	1	1	1	2168083-6	SCR, SKT HD CAP, RoHS, M5 X 65	93
-	1	1	1	1	2119956-1	DOCUMENTATION PACKAGE	71
-	1	-	-	1	2119740-1	TAG, IDENTIFICATION	67
-	2	2	2	2	2168078-1	SCREW, DRIVE, RH, RoHS, 2 x .188	66
-	1	-	-	1	2119793-1	LIMITER, ADJUSTMENT BOLT	63
-	3	-	3	3	992763-5	SCR, SET, SOC, CONE POINT, M3 X 4.0	62
-	1	1	1	1	2-18032-5	SCR, SET, FLT POINT M5 X 20.0	61
-	1	1	1	1	2079383-4	SCR, BHSC, RoHS (M4 X 8)	60
-	-	-	-	1	5-18022-5	SCR, HEX HD CAP, M4 X 6.0	59
-	-	-	-	1	1338685-1	PAWL, FEED	56
-	4	4	4	4	2168400-1	SHCS, LOW HEAD, RoHS, M4 X 12	54
-	2	2	2	2	2168083-8	SCR, SKT HD CAP, RoHS, M4 X 16	53
-	1	1	1	1	5018030-1	NUT, HEX, REG, RoHS, M3	52
-	1	1	1	1	811242-5	BUMPER, HOLD DOWN	51
-	1	1	1	1	690753-2	SPACER, TONKER	50
-	-	-	-	1	18023-9	SCR, SKT HD CAP M4 X 6.0	49
-	1	1	1	1	2-2119656-3	APPLICATOR BASIC ASSEMBLY, SF	46
-	1	-	1	1	2119370-1	RAM, AMP STYLE, SIDE FEED	44
-	1	1	1	1	2079383-7	SCR, BHSC, RoHS (M8 X 25)	41
-	1	-	1	1	2119645-1	DISC, NUMBERED FA WIRE ADJUSTMENT	40
-	1	-	1	1	2119957-1	APPLICATOR SHIM PACK	39
-	1	1	1	1	2119644-2	RAM WASHER, PRECISION	38
-	1	1	1	1	2119085-1	FA HEAD, ATLANTIC STYLE	37
-	1	-	1	1	2119092-1	BOLT, ADJUSTMENT	35
-	1	1	1	1	1-1752356-2	SUPPORT, TERMINAL	34
-	2	2	2	2	2079383-5	SCR, BHSC, RoHS (M4 X 20)	33
-	1	1	1	1	2161328-1	HEX HEAD, FLANGED, M5 X 8mm LONG	32
-	1	1	1	1	2-1320908-2	SPACER, STRIP GUIDE	30
-	1	1	1	1	1901086-1	PLATE, STRIP GUIDE	29
-	1	1	1	1	1-455888-0	SPACER, CRIMPER	28
-	2	2	2	2	22283-1	SPRING, COMPRESSION	27
-	1	1	1	1	356835-1	LEVER, DRAG RELEASE	26
-	1	1	1	1	1803142-1	DRAG, TERMINAL	25
-	1	1	1	1	1320928-2	STRIP GUIDE	24
-	1	1	1	1	980371-4	SCR, SKT HD SHLDR 5.0 DIA X 6.0	23
-	1	1	1	1	2168083-2	SCR, SKT HD CAP, RoHS, M4 X 8.0	21
-	2	2	2	2	1-18028-2	WASHER, FLAT, REG M4	20
-	1	1	1	1	690472-2	STRIPPER	19
-	1	1	1	1	2119806-1	INSERT, SHEAR	13
-	1	1	1	1	3-22280-3	SPRING, COMPRESSION	12
-	1	1	1	1	1-356885-4	STOP, SHEAR	11
-	1	1	1	1	2119805-1	SHEAR HOLDER, FRONT	10
-	1	1	1	1	462006-6	FLOATING SHEAR, FRONT	9
-	1	1	1	1	2161316-4	ANVIL, COMBINATION	8
-	1	1	1	1	2-240641-9	SPACER	7
-	-	-	-	-	-	-	6
-	1	1	1	1	1-1722335-0	SHEAR DEPRESSOR ASSEMBLY	5
-	1	1	1	1	4-238011-5	BLOCK, CRIMPER SPACER	4
-	1	1	1	1	1722335-9	CRIMPER, INSULATION F	3
-	-	-	-	-	-	-	2
-	1	1	1	1	2217303-1	CRIMPER, WIRE, CONICAL BLEND	1
-77	-7	-6	-5	-2	PART NO	DESCRIPTION	ITEM NO

DIMENSIONS:		TOLERANCES UNLESS OTHERWISE SPECIFIED:		DWG		REV		DATE		BY		CHKD	
mm	0 PLC	±		21	ZHAO	07FEB2013							
	1 PLC	±		07	ELBIN	07FEB2013							
	2 PLC	±											
	3 PLC	±											
	4 PLC	±											
	ANGLES	±											
	FINISH	±											

Customer Accessible Production Drawing SCALE 1:2 SHEET 1 OF 4 REV G

REVISONS		DATE	OWN	APVD
LOC	DIST			
A	66			
P	LTM	DESCRIPTION		
		SEE SHEET 1		

# FEED TYPE

## PNEUMATIC

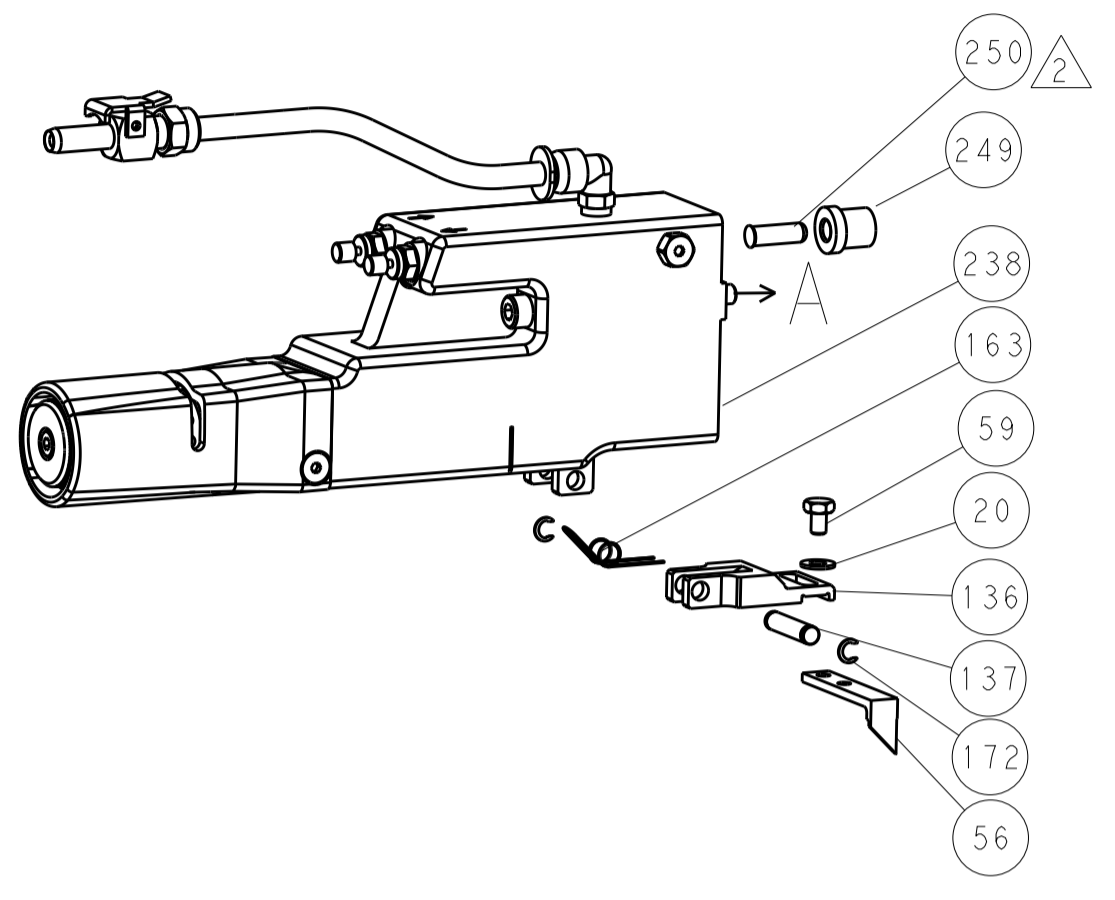

## SERVO LATCH PLATE

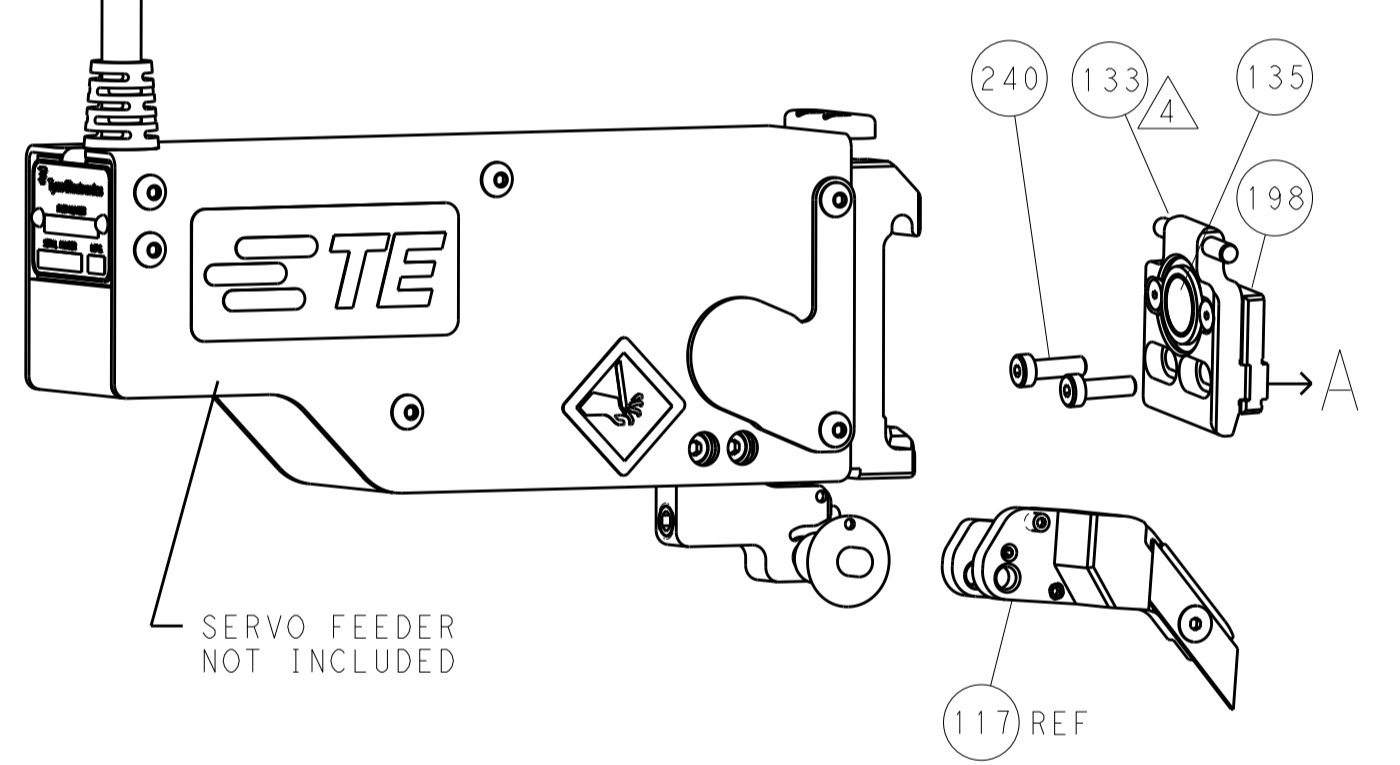

## CAM POSITION

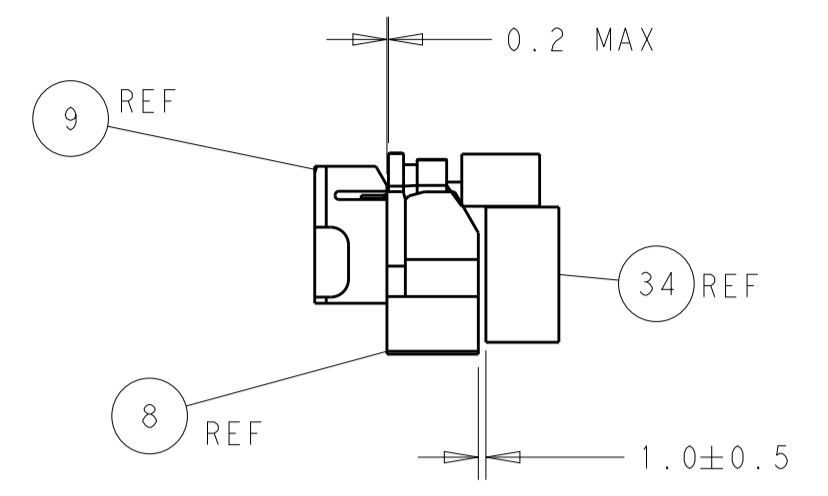
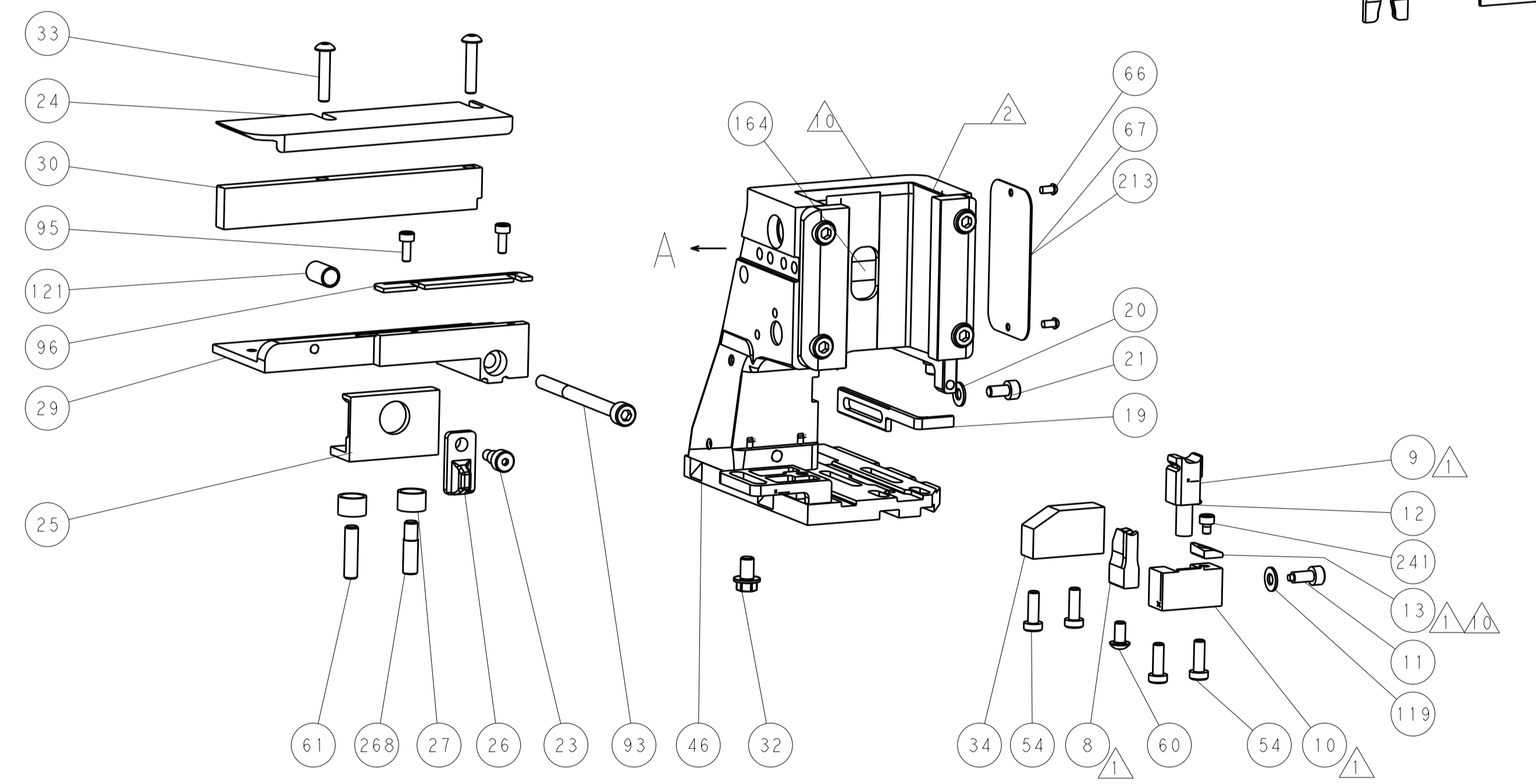
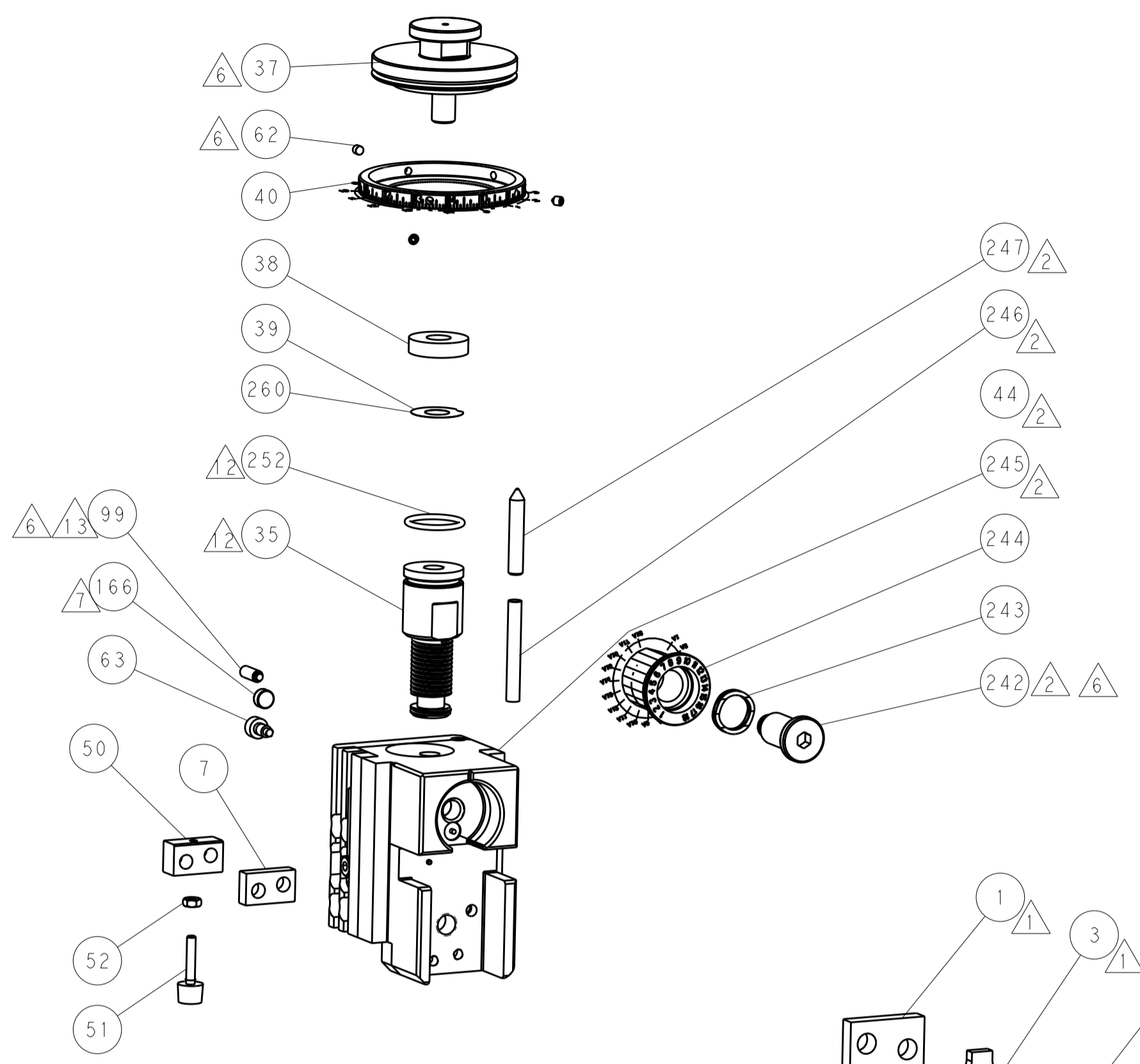
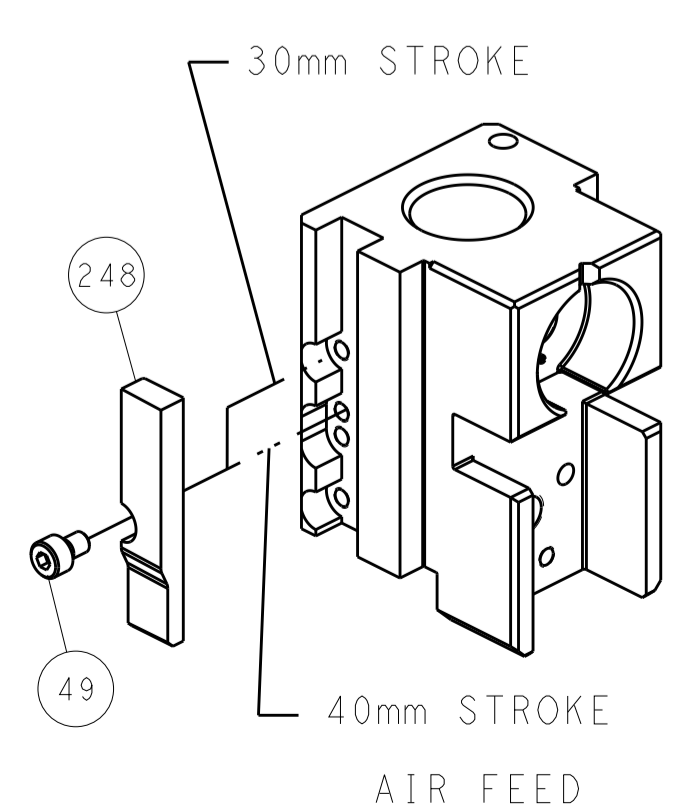

TERMINAL SUPPORT LOCATION

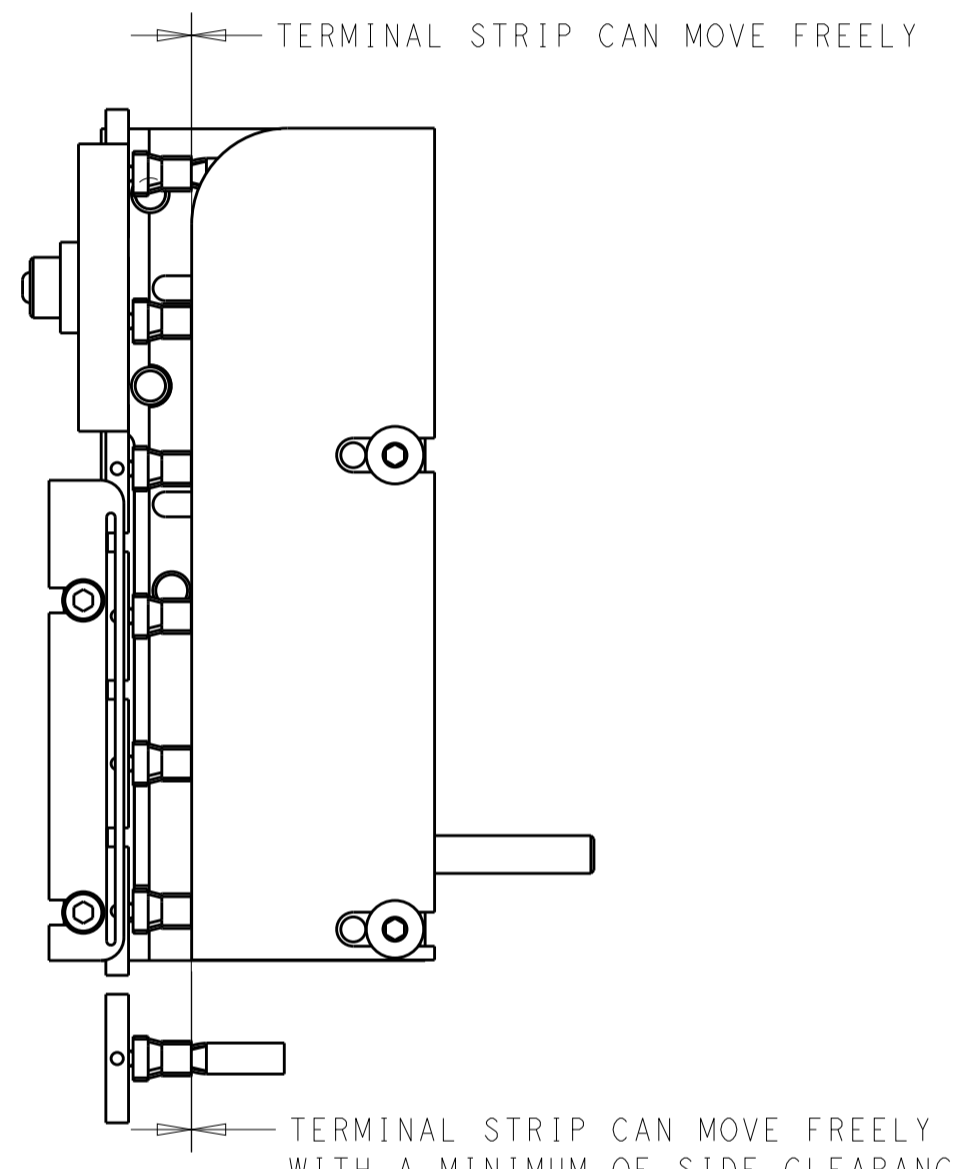

FEED TRACK POSITION

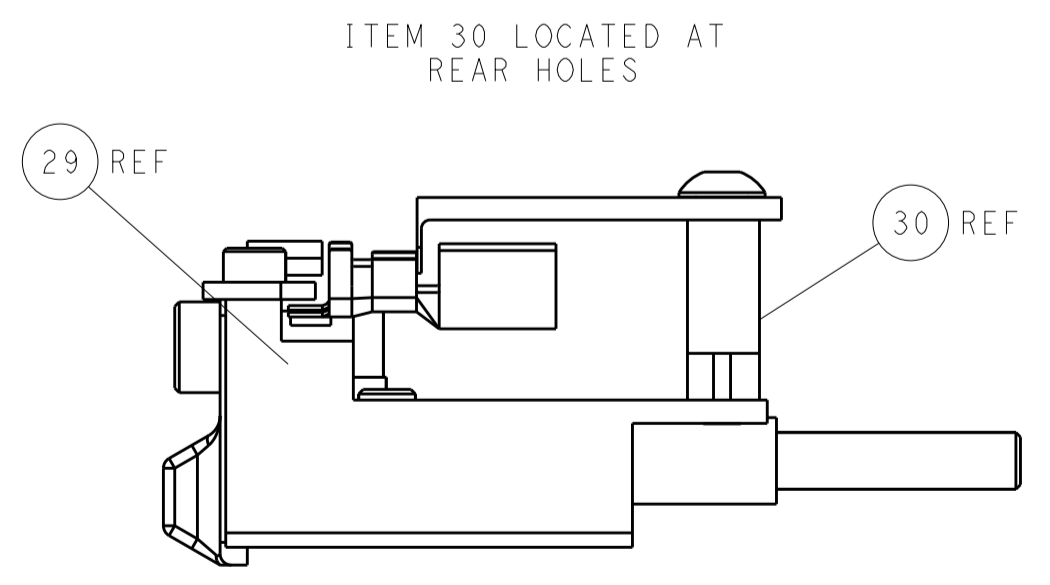

FEED TRACK POSITION GUIDE BY WIRE BARREL

**ATLANTIC VERSION**  
 Shown on sheets 1 of 4 & 2 of 4  
 (Pacific version shown on sheets 3 of 4 & 4 of 4)

DIMENSIONS:		TOLERANCES UNLESS OTHERWISE SPECIFIED:		DWN X.ZHAO 07FEB2013		TE Connectivity	
mm	0 PLC ±	1 PLC ±	2 PLC ±	3 PLC ±	4 PLC ±	Harrisburg, PA 17105-3608	
	ANGLES ±			CHK T.ELBIN 07FEB2013		NAME	
				S.XI 07FEB2013		Ocean Side Feed	
				APVD		Applicator	
				PRODUCT SPEC			
				APPLICATION SPEC			
MATERIAL	FINISH	WEIGHT	SCALE	SIZE	CAGE CODE	DRAWING NO	RESTRICTED TO
			1:2	A1	00779	©=2151818	
Customer Accessible Production Drawing				SHEET	2	OF	4
				REV	G		

PACIFIC VERSION TERMINATOR INTERFACE ADAPTER	PART NUMBER	REVISION	DESCRIPTION	FEED TYPE	APPLICATOR STYLE CONVERSION CHART					
					CONVERT TO	PART NUMBERS REQUIRED				
	2-2151818-2	G	FINE CRIMP HEIGHT ADJUST	PNEUMATIC	-	1338685-1	5-18022-5	-	-	-
					SERVO LATCH PLATE	2119951-1	8-2151818-5	1901094-3	2168400-6 (QUANTITY 2)	
	2-2151818-5	G	FINE CRIMP HEIGHT ADJUST	SERVO LATCH PLATE	-	1338685-1	5-18022-5	-	-	-
					PNEUMATIC FEED	2119950-1	1338685-1	5-18022-5	2119641-2	2119799-1
2-2151818-7	G	FINE CRIMP HEIGHT ADJUST	NONE	-	-	-	-	-	-	
7-2151818-7	A	CRIMP TOOLING KIT	-	-	-	-	-	-	-	

APPLICATOR DATA		
CRIMP	SIZE	TYPE
WIRE	4.06 mm [.160]	F
INSUL	4.83 mm [.190]	F
APPLICATOR INSTRUCTIONS 408-10389		

TERMINAL DATA: TE TERMINAL		TE CRIMP SPECIFICATION
TERMINAL NAME: SPT LITEALUM CONTACT		
WIRE STRIP LENGTH 3.90-4.50 mm [.154-.177 IN]		INSULATION DIAMETER RANGE 4.13-4.38 mm [.163-.172 IN]
TERMINAL APPLICATION SPECIFICATION 114-94204	-	-
TERMINALS APPLIED		
TE TERMINAL	TE TERMINAL	TE TERMINAL
2-1862004-1		

WIRE SIZE	CRIMP HEIGHT mm [INCH]	CRIMP HEIGHT REFERENCE SETTING
6.00mm2	2.10±0.04 [.0827±.0016]	7.8

- RECOMMENDED SPARE PARTS
- GREASE BEARING SURFACES LIGHTLY
- LUBRICATE DAILY PER THE APPLICATOR INSTRUCTION SHEET SUPPLIED WITH THE APPLICATOR.
- APPLICATOR SPECIFIC DATA TO BE ENTERED INTO BLANK MEMORY CHIP AT ASSEMBLY. SEE BELOW FOR PART NUMBER:  
 PNEUMATIC FEED WITH "SMART APPLICATOR" CONVERSION: 8-2151818-4  
 SERVO FEED WITH "FINE CRIMP HEIGHT ADJUST": 8-2151818-5
- ADJUSTMENT OF THE STRIPPER MAY BE REQUIRED WHEN MOVING THE APPLICATOR BETWEEN BENCH AND LEADMAKER APPLICATIONS.
- APPLY PART NUMBER 1-23419-5 LOCTITE TO THREADS OF ITEMS 62.  
 APPLY PART NUMBER 2-23419-6 LOCTITE TO THREADS OF ITEMS 99 & 242.
- MAGNET MUST BE ORIENTED CORRECTLY IN ORDER TO PROPERLY ACTUATE THE COUNTER.
- CRIMP HEIGHT REFERENCE SETTING WAS THE SETTING USED WHEN THE APPLICATOR WAS QUALIFIED AT THE FACTORY. ADJUSTMENT MAY BE NECESSARY WHEN RUNNING APPLICATOR IN THE FIELD.
- TERMINAL PITCH NOT COMPATIBLE WITH MECHANICAL FEED.
- TO CONVERT THE APPLICATOR TO A NON-CARRIER CUTTING STYLE, REMOVE ITEM 13 AND ATTACH TO THE LOCATION ON BACK SIDE OF THE HOUSING. REFER TO INSTRUCTION SHEET FOR ADDITIONAL INFORMATION.
- GREASE THREADS, GROOVE AND O-RING ON ITEMS 139 & 152.
- SET THE FINE CRIMP HEIGHT ADJUSTMENT HEAD TO PROPER CRIMP HEIGHT PRIOR TO TIGHTENING/LOCKING THE BRASS TIP SET SCREW, ITEM 99, AGAINST THE ADJUSTMENT BOLT THREADS.
- APPLICATOR TO BE USED IN CONJUNCTION WITH LEADMAKER INTIGRATION KIT, P/N 2280475-1 FOR CLAMPING AND SENSING OF FEED TRACK.

**\*WARNING**  
 ON INSTALLATION, SET WIRE DISC, ITEM 40 TO LARGEST WIRE SIZE SETTING. USE OF SETTINGS BELOW MINIMUM REQUIRED CRIMP HEIGHT SETTING WILL CAUSE DAMAGE TO CRIMP TOOLING.

-	1	1	1	2-1722335-1	THREAD BOLT GEWINDEBOLZEN	268
-	1	1	1	2119782-1	FINE ADJUST HEAD ASM, PACIFIC STYLE	251
-	-	-	1	2119640-1	PUSH ROD, AIR FEED	250
-	-	-	1	2079988-1	BUSHING, LCH5-12, MISUMI	249
-	1	1	1	1-22279-3	SPRING, COMPRESSION	246
-	1	1	1	2119082-3	CAM, SNAIL, INSULATION ADJUSTMENT	244
-77	-27	-25	-22	PART NO	DESCRIPTION	ITEM NO

**PACIFIC VERSION**  
 Shown on sheets 3 of 4 & 4 of 4  
 (Atlantic version shown on sheets 1 of 4 & 2 of 4)

SET UP GAUGE	LOC	DIST	REVISIONS			
2119599-1	A	66	REV	DATE	BY	APPV
			-	SEE SHEET 1	-	-

-	1	1	1	2079764-1	WASHER, WAVE SPRING, CREST-TO-CREST	243
-	1	1	1	2119083-1	RETAINER, INSULATION DIAL	242
-	1	1	1	7-18023-7	SCR, SKT HD CAP M3 X 4.0	241
-	-	2	-	2168400-6	SHCS, LOW HEAD, RoHS, M5 X 16	240
-	-	-	1	2063440-1	AIR FEED MODULE	238
-	-	1	-	2119740-2	TAG, IDENTIFICATION	213
-	-	1	-	1901094-3	SPACER, FEEDER	198
-	-	-	2	21045-3	RING, RETAIN, EXTERN, 3/16 CRESCENT	172
-	1	1	1	994969-1	MAGNET, RARE EARTH HIGH ENERGY	166
-	REF	REF	REF	994970-2	COUNTER, MAGNETIC	164
-	-	-	1	240638-1	SPRING, FEED FINGER	163
-	1	1	1	8-21084-1	O-RING, .801 ID, .070 DIA. MAT.	152
-	-	-	1	2119641-2	FEED CAM, AIR FEED	151
-	1	1	1	2119798-2	DETENT PIN	145
-	1	1	1	2079383-8	SCR, BHSC, RoHS (M4 X 16)	144
-	4	4	4	2168400-5	SHCS, LOW HEAD, RoHS, M4 X 20	143
-	1	1	1	2-2119656-4	APPLICATOR BASIC ASSEMBLY, SF	141
-	1	1	1	2119650-1	RAM, ASIAN STYLE, SIDE FEED	140
-	1	1	1	2119092-2	BOLT, ADJUSTMENT	139
-	-	-	1	3-23627-7	PIN, RETAIN, GRVD, 3/16 X .854	137
-	-	-	1	2119799-1	HOLDER, FEED FINGER, AF	136
-	-	REF	-	SEE NOTE 4	MEMORY CHIP, PROGRAMMED	135
-	-	1	-	1633743-1	SERVO FEED LATCH ASM	133
-	1	1	1	1-22281-8	SPRING, COMPRESSION	121
-	1	1	1	1-18028-2	WASHER, FLAT, REG M4	119
-	1	1	1	2256587-1	SCR, SET, SOFT TIP, M4	99
-	1	1	1	1-690438-0	FRONT STRIP GUIDE	96
-	2	2	2	2168083-1	SCR, SKT HD CAP, RoHS, M3 X 8.0	95
-	1	1	1	2168083-6	SCR, SKT HD CAP, RoHS, M5 X 65	93
-	1	1	1	2119956-1	DOCUMENTATION PACKAGE	71
-	1	-	1	2119740-1	TAG, IDENTIFICATION	67
-	2	2	2	2168078-1	SCREW, DRIVE, RH, RoHS, 2 x .188	66
-	1	1	1	2119793-1	LIMITER, ADJUSTMENT BOLT	63
-	3	3	3	992763-5	SCR, SET, SOC, CONE POINT, M3 x 4.0	62
-	1	1	1	2-18032-5	SCR, SET, FLT POINT M5 X 20.0	61
-	-	-	1	5-18022-5	SCR, HEX HD CAP, M4 X 6.0	59
-	-	-	1	1338685-1	PAWL, FEED	56
-	2	2	2	2168083-8	SCR, SKT HD CAP, RoHS, M4 X 16	53
-	1	1	1	5018030-1	NUT, HEX, REG, RoHS, M3	52
-	1	1	1	811242-5	BUMPER, HOLD DOWN	51
-	1	1	1	690753-2	SPACER, TONKER	50
-	-	-	1	18023-9	SCR, SKT HD CAP M4 X 6.0	49
-	1	1	1	2079383-7	SCR, BHSC, RoHS (M8 X 25)	41
-	1	1	1	2119645-1	DISC, NUMBERED FA WIRE ADJUSTMENT	40
-	1	1	1	2119957-1	APPLICATOR SHIM PACK	39
-	1	1	1	2119644-2	RAM WASHER, PRECISION	38
-	1	1	1	1-1752356-2	SUPPORT, TERMINAL	34
-	2	2	2	2079383-5	SCR, BHSC, RoHS (M4 X 20)	33
-	1	1	1	2161328-1	HEX HEAD, FLANGED, M5 x 8mm LONG	32
-	1	1	1	2-1320908-2	SPACER, STRIP GUIDE	30
-	1	1	1	1901086-1	PLATE, STRIP GUIDE	29
-	1	1	1	1-455888-0	SPACER, CRIMPER	28
-	2	2	2	22283-1	SPRING, COMPRESSION	27
-	1	1	1	356835-1	LEVER, DRAG RELEASE	26
-	1	1	1	1803142-1	DRAG, TERMINAL	25
-	1	1	1	1320928-2	STRIP GUIDE	24
-	1	1	1	980371-4	SCR, SKT HD SHLDR 5.0 DIA X 6.0	23
-	1	1	1	2168083-2	SCR, SKT HD CAP, RoHS, M4 X 8.0	21
-	2	2	2	1-18028-2	WASHER, FLAT, REG M4	20
-	1	1	1	690472-2	STRIPPER	19
-	1	1	1	2119806-1	INSERT, SHEAR	13
-	1	1	1	3-22280-3	SPRING, COMPRESSION	12
-	1	1	1	1-356885-4	STOP, SHEAR	11
-	1	1	1	2119805-1	SHEAR HOLDER, FRONT	10
-	1	1	1	462006-6	FLOATING SHEAR, FRONT	9
-	1	1	1	2161316-4	ANVIL, COMBINATION	8
-	1	1	1	2-240641-9	SPACER	7
-	-	-	-	-	-	6
-	1	1	1	1-1722335-0	SHEAR DEPRESSOR ASSEMBLY	5
-	1	1	1	4-238011-5	BLOCK, CRIMPER SPACER	4
-	1	1	1	1722335-9	CRIMPER, INSULATION F	3
-	-	-	-	-	-	2
-	1	1	1	2217303-1	CRIMPER, WIRE, CONICAL BLEND	1
-77	-27	-25	-22	PART NO	DESCRIPTION	ITEM NO

DIMENSIONS:		TOLERANCES UNLESS OTHERWISE SPECIFIED:		DWG		REV	
mm	0 PLC ±	1 PLC ±	2 PLC ±	3 PLC ±	4 PLC ±	5 PLC ±	6 PLC ±
	ANGLES	FINISH					
MATERIAL				WEIGHT			

CHK	DATE	NAME
X. ZHAO	07FEB2013	
T. ELBIN	07FEB2013	
S. XI	07FEB2013	

SIZE	CAGE CODE	DRAWING NO	RESTRICTED TO
A1	00779	2151818	

Customer Accessible Production Drawing SCALE 1:2 SHEET 3 OF 4 REV G

# FEED TYPE

## PNEUMATIC

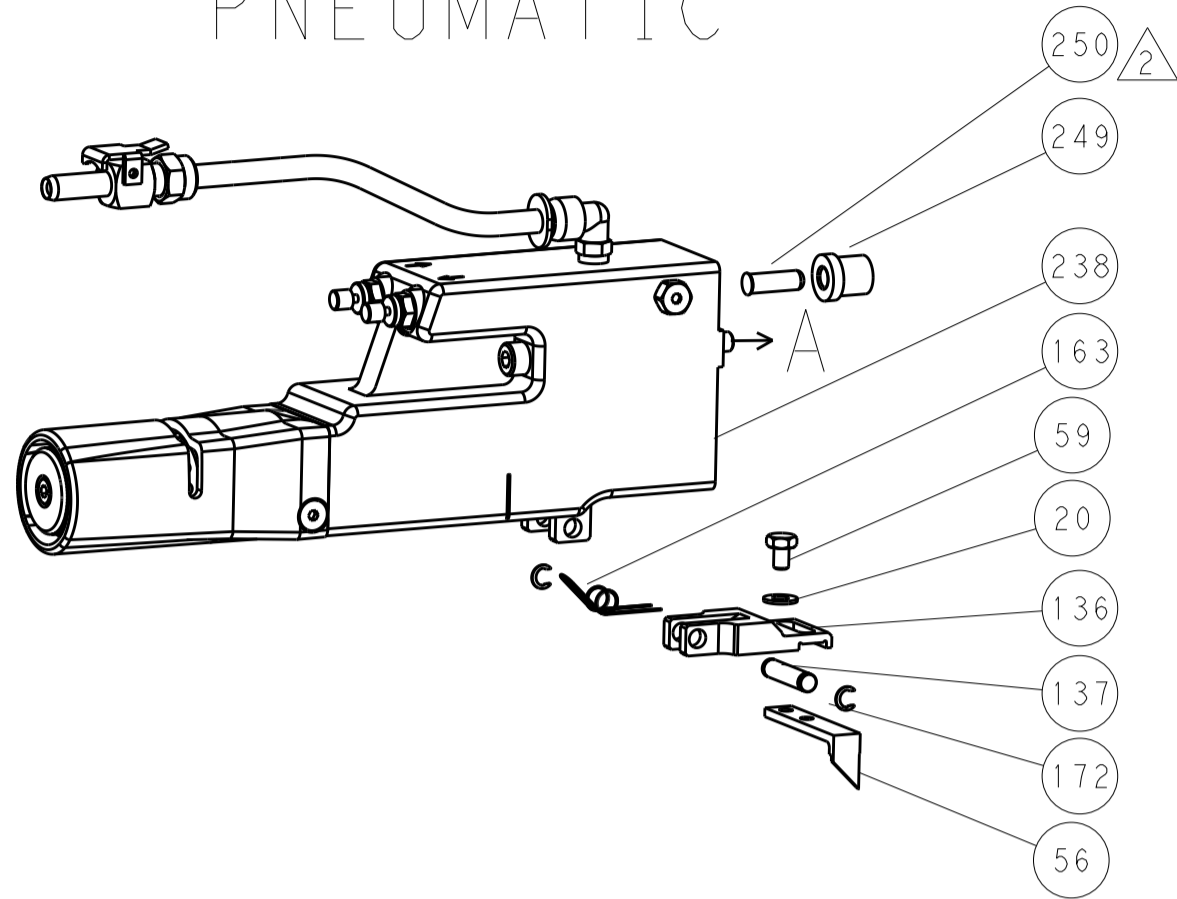

## SERVO LATCH PLATE

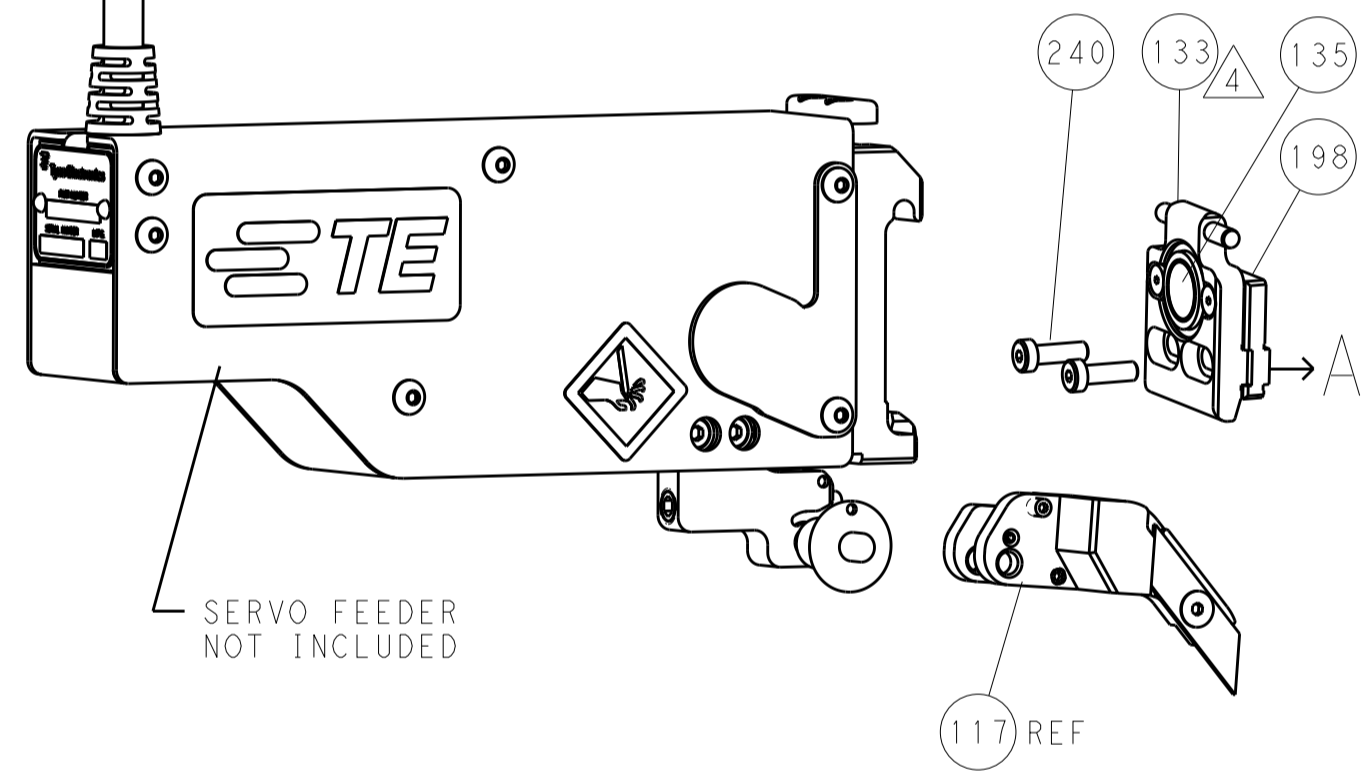

## CAM POSITION

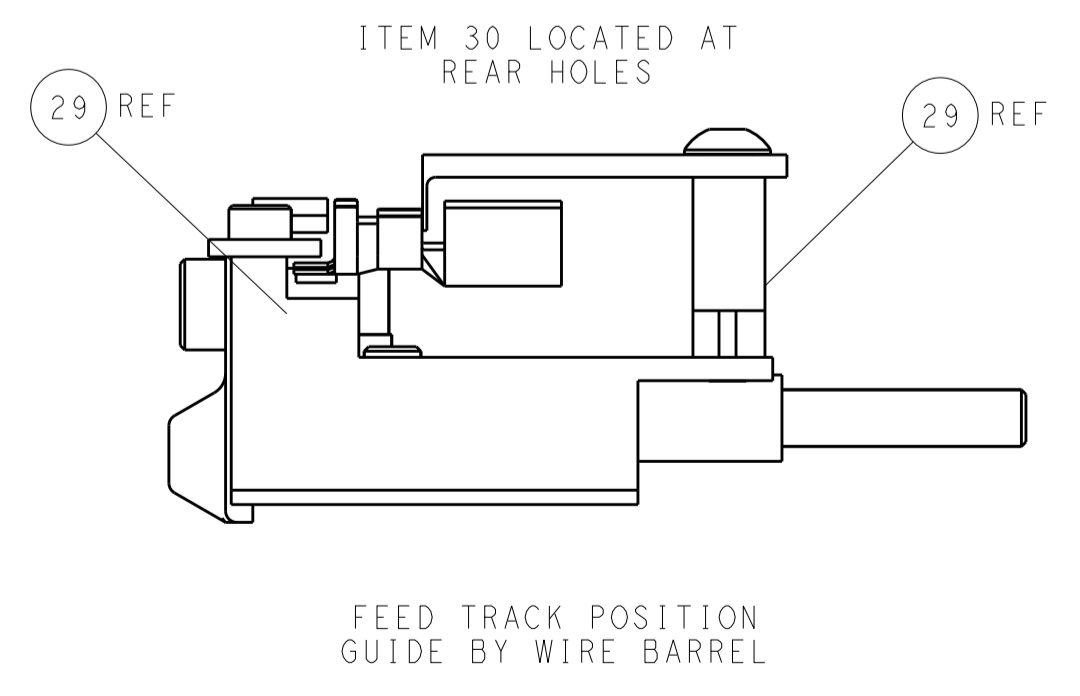
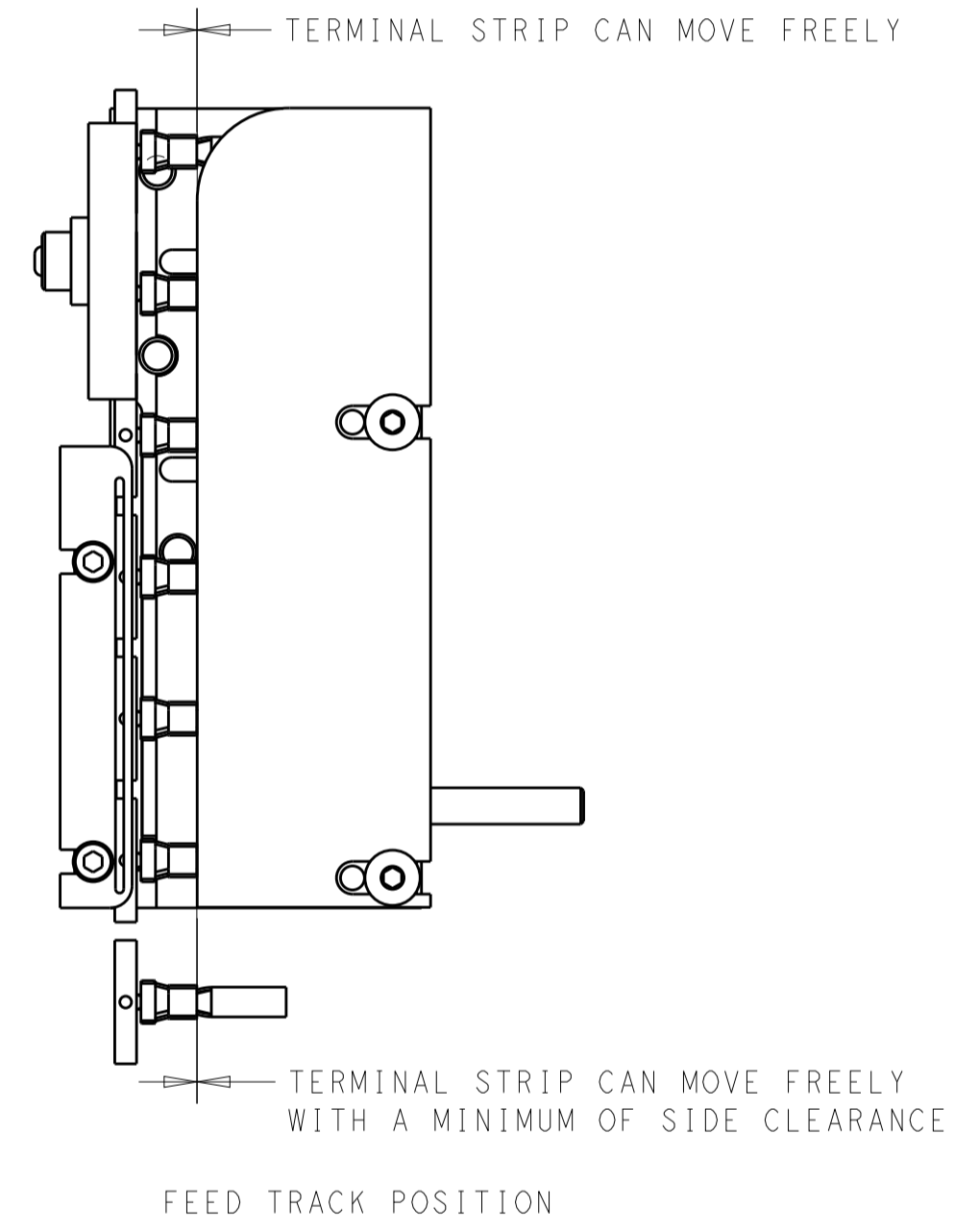
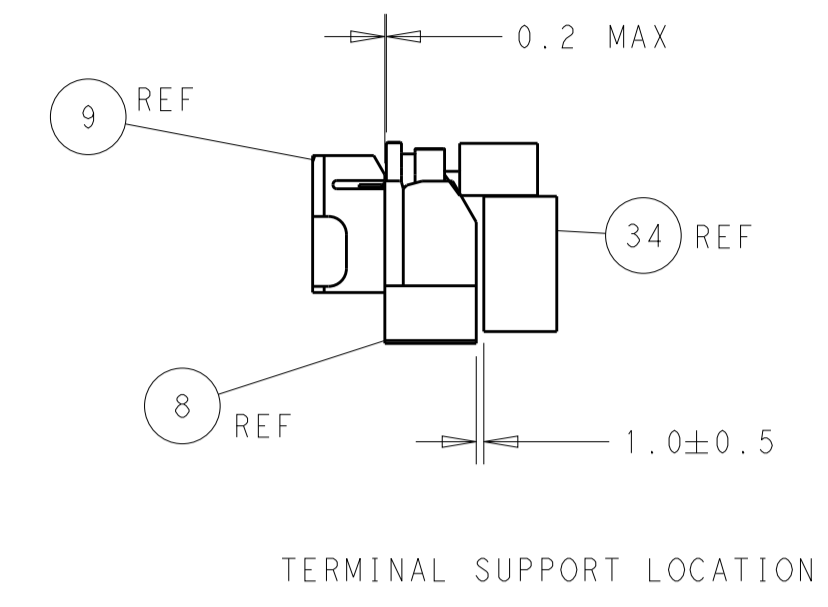
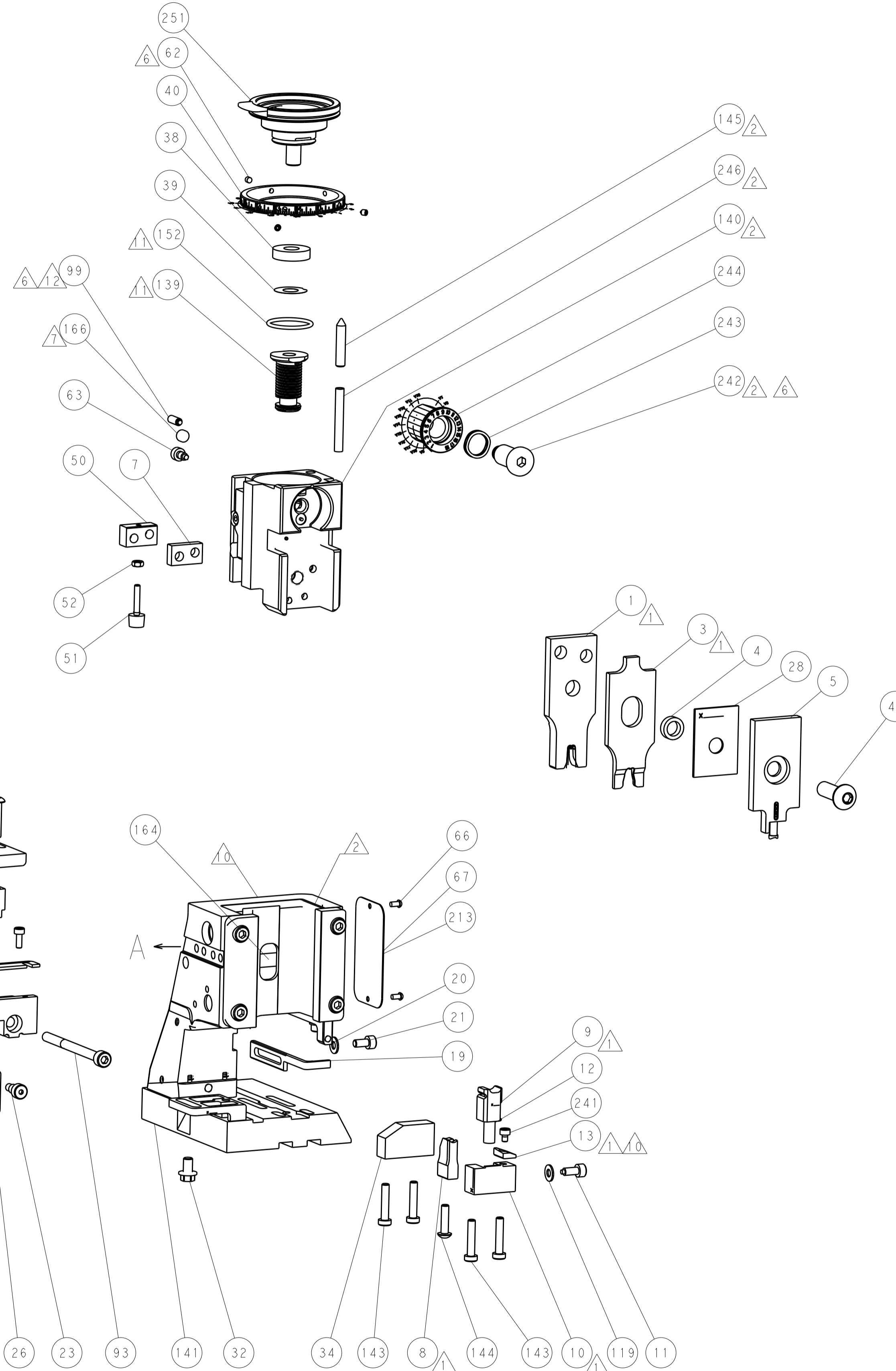
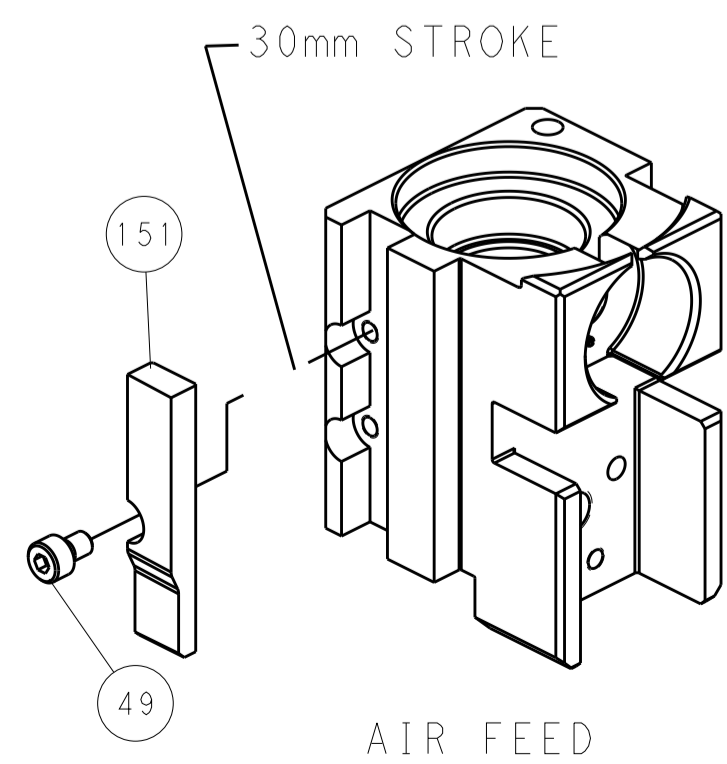

**PACIFIC VERSION**  
 Shown on sheets 3 of 4 & 4 of 4  
 (Atlantic version shown on sheets 1 of 4 & 2 of 4)

LOC	DIST	REV	DESCRIPTION	DATE	OWN	APVD
A	66		SEE SHEET 1			

DIMENSIONS: mm 		TOLERANCES UNLESS OTHERWISE SPECIFIED: 0 PLC ± 1 PLC ± 2 PLC ± 3 PLC ± 4 PLC ± ANGLES ±		DWN X.ZHAO 07FEB2013 CHK T.ELBIN 07FEB2013 APVD S.XI 07FEB2013 PRODUCT SPEC APPLICATION SPEC WEIGHT SCALE 1:2		NAME Ocean Side Feed Applicator SIZE CAGE CODE DRAWING NO A1 00779 C=2151818 SHEET 4 OF 4 REV G	
MATERIAL FINISH				RESTRICTED TO Customer Accessible Production Drawing			