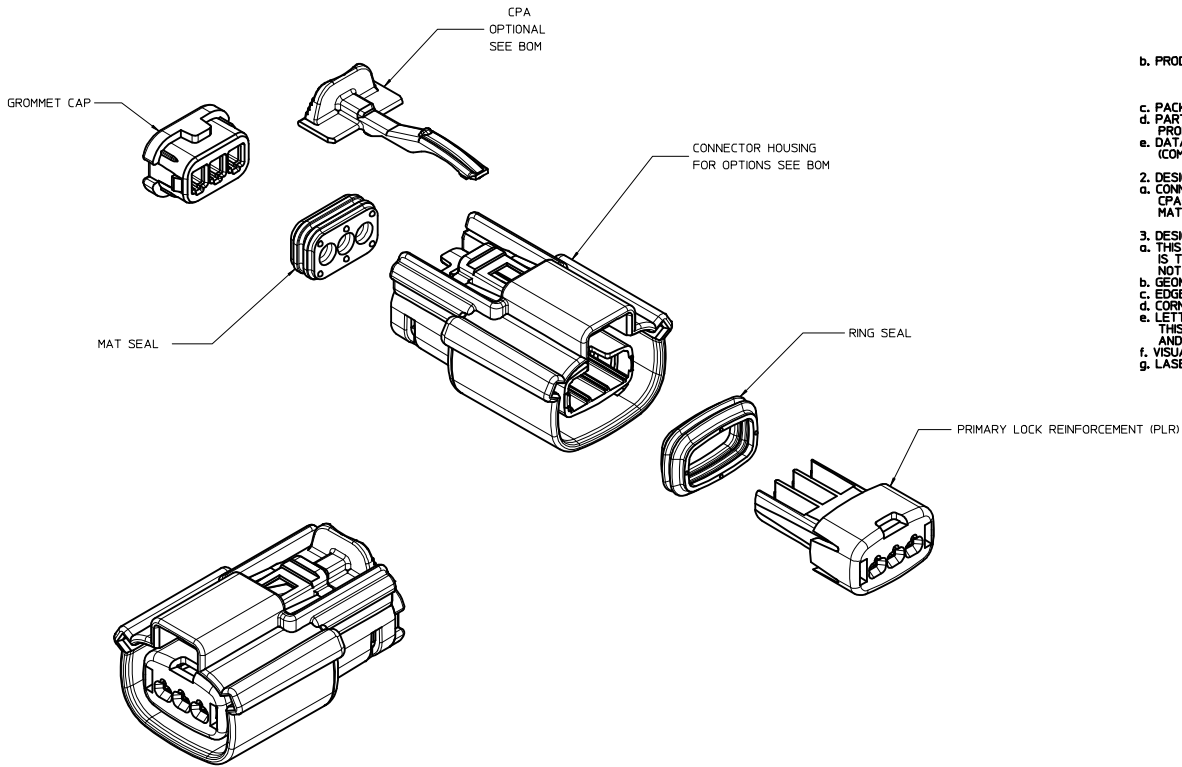

TABLE OF CONTENTS	
SHEET NO.	SHEET DESCRIPTION
1	NOTES
2	KEY CONFIGURATIONS
3	RECEPTACLE SEALED ASSEMBLY
4	BOM



NOTES: VALID UNLESS OTHERWISE SPECIFIED

1. GENERAL:
  - a. APPLICATION SPECIFICATION SEE: AS-33472-100
    - CONTAINS: PRODUCT INTRODUCTION, PRODUCT SUMMARY, CONNECTOR ASSEMBLY, PACKAGING INFORMATION, CONNECTOR MATING, SERVICE INSTRUCTIONS, ELECTRICAL CONTINUITY CHECKING, CRIMPING, AND TROUBLESHOOTING.
    - DESIGNED TO MATE WITH DEVICE CONNECTION AS SPECIFIED IN DRAWING EWCAP 150-S-003-1-205, AVAILABLE AT <a href="http://ewcap.uscarteams.org/">http://ewcap.uscarteams.org/.
    - DESIGNED TO MATE WITH BLADE SEALED ASSEMBLY AS SPECIFIED IN DRAWING SD-33481-031
    - FOR 15mm RECEPTACLE TERMINALS TO BE USED WITH THIS ASSEMBLY. SEE MOLEX DRAWING SD-33012-002.
    - SYSTEM TO BE USED WITH WIRE WITHIN DIAMETER RANGE OF 1.2 mm TO 2.69 mm.
    - ASSEMBLY SHIPPED WITH PLR AND CPA IN PRE-LOCK POSITION (SEE SECTION Z-Z PRE-LOCK).
    - IN THE EVENT THAT THE PLR IS FOUND IN THE SEATED (FINAL LOCK) POSITION, REFER TO MOLEX SPECIFICATION PS-34646-001, AVAILABLE AT [www.molex.com](http://www.molex.com) -<http://www.molex.com>.
    - ASSEMBLY CONFORMS TO SAE/USCAR-2 REV.4 WITH THE FOLLOWING EXCEPTIONS: ENGAGEMENT FORCE TO MOVE CPA FROM PRE-LOCK TO FINAL LOCK POSITION WHEN UNMATED: 40N MIN. DISENGAGEMENT FORCE TO MOVE CPA FROM FINAL LOCK TO PRE-LOCK POSITION: 3N MIN, 40N MAX. TERMINAL INSERTION FORCE FOR WIRE DIAMETER ABOVE 2.5mm NOT EXCEEDING 2.69mm SHALL NOT EXCEED 40 NEWTONS.
  - b. PRODUCT SPECIFICATION SEE: PS-33471-000
    - CONTAINS: PRODUCT INTRODUCTION, PRODUCT SUMMARY, RATINGS (CURRENT, TEMPERATURE, SEALING, AND FLAMMABILITY), AND PRODUCT VALIDATION.
  - c. PACKAGING SPECIFICATION PER MOLEX DRAWING: PK-31300-635
  - d. PARTS MUST BE IN COMPLIANCE TO MOLEX CHEMICAL SUBSTANCES FOR PRODUCTS AND PACKAGING SPECIFICATION: ES-40000-5016
  - e. DATA MUST BE SUBMITTED UNDER THE MOLEX PART NUMBER TO IMDS (COMPANY ID#13255)
2. DESIGN - MATERIALS:
  - a. CONNECTOR HOUSING, GROMMET CAP, PLR: SPS/NYLON BLEND 20% GLASS FILLED
  - CPA: PBT 20% GLASS FILLED
  - MAT SEAL, RING SEAL: INHERENTLY LUBRICATED SILICONE
3. DESIGN - GEOMETRY:
  - a. THIS IS A 100% CAD GENERATED PART. THE CAD MATHEMATICAL DATA IS THE MASTER FOR THIS PART. FOR DIMENSIONAL OR ANY INFORMATION NOT SHOWN ON THIS DRAWING, ANALYZE THE CAD MODEL.
  - b. GEOMETRIC DIMENSIONS AND TOLERANCES PER ASME Y14.5M - 1994
  - c. EDGES AND UNDIMENSIONED DETAILS PER ISO13715
  - d. CORNERS SHOWN AS SHARP TO BE R 0.2 MAX.
  - e. LETTERING SHALL BE 0.15 MAX RAISED IN 0.25 MAX RECESS PAD. THIS INCLUDES RECYCLING CODE, CAVITY ID, VENDOR IDENTIFICATION, AND CUSTOMER MATERIAL NUMBER.
  - f. VISUAL DEFECTS SHALL MEET COSMETIC STANDARD PS-45499-002 (Class B)
  - g. LASER MARKING: TBD

INSPECTION NUMBER LOG  
 LAST NUMBER USED: 5  
 ADDED:  
 REMOVED:

REV	DESCRIPTION
Q1	UPDATED NOTES
0	REDRAWN

<b>ENTER DESCRIPTION</b> IEC NO: UAU2013-0423 DRAWN: KUNNINGHAM 2012/09/11 CHKD: APPR: WOSHY 2012/09/17 REV	QUALITY SYMBOLS ▽=0 ▽=0 ▽=0 ▽=0	GENERAL TOLERANCES (UNLESS SPECIFIED): 4 PLACES ± .005 3 PLACES ± .004 2 PLACES ± 0.1 1 PLACE ± 0.30 0 PLACE ±	DIMENSION STYLE MM ONLY	DRAWN BY: DMARCOUX DATE: 06/18/2002 CHECKED BY: DGRIFITHS DATE: 6/18/2002 APPROVED BY: FHOLUB DATE: 06/18/2002	SCALE: 3:1 DESIGN UNITS: METRIC THIRD ANGLE PROJECTION	TITLE: MX150 1X3 RECEPTACLE SEALED ASSEMBLY MAT SEAL <b>molex</b>	MATERIAL NO.: SEE BOM DOCUMENT NO.: SD-33471-031	SHEET NO.: 1 OF 4
	DRAFT WHERE APPLICABLE MUST REMAIN WITHIN DIMENSIONS							
	THIS DRAWING CONTAINS INFORMATION THAT IS PROPRIETARY TO MOLEX INCORPORATED AND SHOULD NOT BE USED WITHOUT WRITTEN PERMISSION							
	SIZE: D							

KEY CONFIGURATIONS

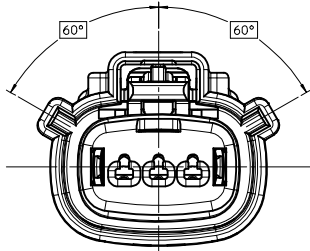

KEY A

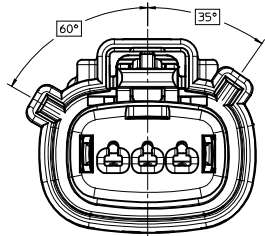

KEY B

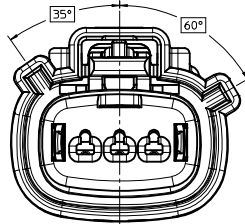

KEY C

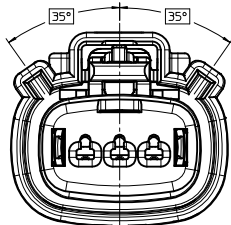

KEY D

<b>ENTER DESCRIPTION</b> IEC NO. UAU2013-0423 DRAWN/CUNNINGHAM 2012/09/11 CHKD: APPR: WOSHY 2012/09/17 REVISIONS:	QUALITY SYMBOLS ▽=0 ▽=0 ▽=0	GENERAL TOLERANCES (UNLESS SPECIFIED) mm INCH 4 PLACES ± --- ± --- 3 PLACES ± --- ± --- 2 PLACES ± 0.1 ± --- 1 PLACE ± 0.30 ± --- 0 PLACE ± ±	DIMENSION STYLE MM ONLY	SCALE 4:1	DESIGN UNITS METRIC	THIRD ANGLE PROJECTION	
	DRAFT WHERE APPLICABLE MUST REMAIN WITHIN DIMENSIONS	ANGLAR ± 3 °	DRAWN BY DMARCOUX 06/18/2002	DATE 06/18/2002	TITLE MX150 1X3 RECEPTACLE SEALED ASSEMBLY MAT SEAL		
	SIZE D	MATERIAL NO. SEE BOM	APPROVED BY FHOLUB 06/18/2002	DATE 06/18/2002	DOCUMENT NO. SD-33471-031		
	THIS DRAWING CONTAINS INFORMATION THAT IS PROPRIETARY TO MOLEX INCORPORATED AND SHOULD NOT BE USED WITHOUT WRITTEN PERMISSION						SHEET NO. 2 OF 4

LASER MARKING ON THIS SURFACE  
SEE NOTE 3g.

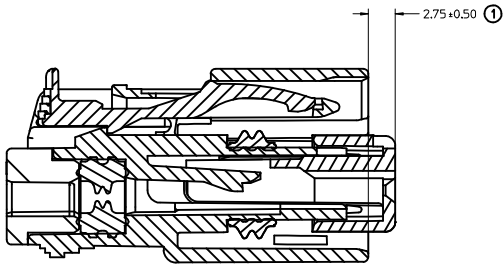
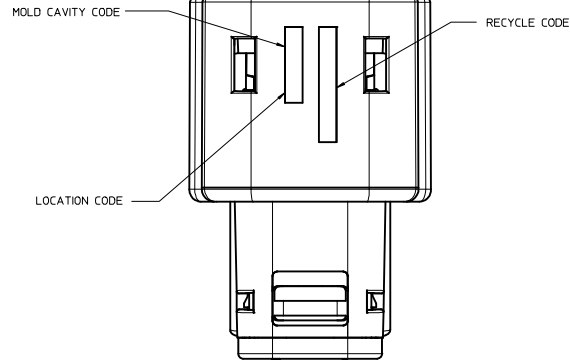
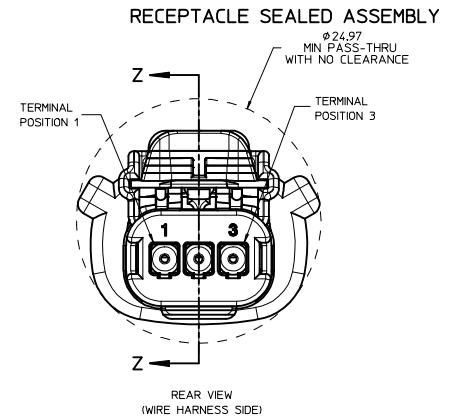
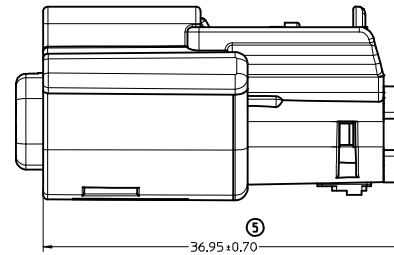
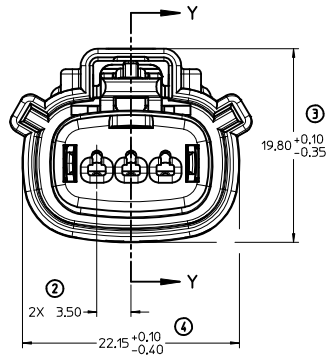
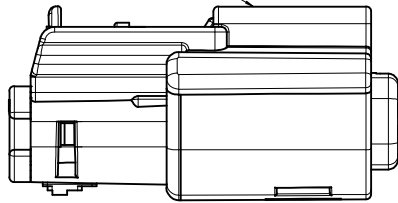

PRIMARY LOCK REINFORCEMENT (PLR) SHOWN  
IN PRE-STAGED POSITION

SECTION Z-Z

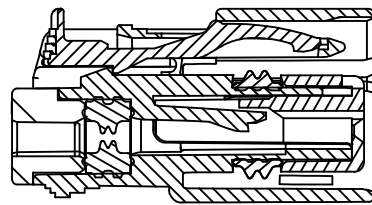

PRIMARY LOCK REINFORCEMENT (PLR) SHOWN  
IN FINAL LOCK POSITION

SECTION Y-Y

<b>ENTER DESCRIPTION</b> IEC NO. UAU2013-0423 DRAWN/CUNNINGHAM 2012/09/11 CHKD: APPR: WOSHY 2012/09/17 REV DESCRIPTION	QUALITY SYMBOLS ∇=0 ∇=0 ∇=0		GENERAL TOLERANCES (UNLESS SPECIFIED) mm INCH 4 PLACES ± --- ± --- 3 PLACES ± 0.1 ± --- 2 PLACES ± 0.30 ± --- 1 PLACE ± ± --- 0 PLACE ± ±		DIMENSION STYLE MM ONLY		SCALE 4:1		DESIGN UNITS METRIC		THIRD ANGLE PROJECTION	
	DRAWN BY DATE DMARCOUX 06/18/2002		CHECKED BY DATE DGRIFITHS 6/18/2002		APPROVED BY DATE FHOLUB 06/18/2002		MATERIAL NO. SEE BOM		DOCUMENT NO. SD-33471-031		SHEET NO. 3 OF 4	
	ANGULAR ± 3 °		DRAFT WHERE APPLICABLE MUST REMAIN WITHIN DIMENSIONS		SIZE D		THIS DRAWING CONTAINS INFORMATION THAT IS PROPRIETARY TO MOLEX INCORPORATED AND SHOULD NOT BE USED WITHOUT WRITTEN PERMISSION					
	MOLEX											

ASSEMBLY PART NUMBER	COLOR	KEYING OPTION	COPY TYPE & STATUS X=PLUMB			CPA	STATUS
			1	2	3		
33471-0301	BLACK	A				-	SALEABLE
33471-0302	LT.GRAY	B				-	SALEABLE
33471-0303	BROWN	C				-	NOT RECOMMENDED--SEE P/N 33471-0343
33471-0304	GREEN	D				-	NOT RECOMMENDED--SEE P/N 33471-0344
33471-0305							VOIDED
33471-0306	BLACK	A				YES	SALEABLE
33471-0307	LT.GRAY	B				YES	SALEABLE
33471-0308	BROWN	C				YES	NOT RECOMMENDED--SEE P/N 33471-0345
33471-0309	GREEN	D				YES	NOT RECOMMENDED--SEE P/N 33471-0346
33471-0310							VOIDED
33471-0311	BLACK	A			X	-	SALEABLE
33471-0312	LT.GRAY	B			X	-	SALEABLE
33471-0313	BROWN	C			X	-	SALEABLE
33471-0314	GREEN	D			X	-	SALEABLE
33471-0315							VOIDED
33471-0316	BLACK	A			X	YES	SALEABLE
33471-0317	LT.GRAY	B			X	YES	SALEABLE
33471-0318	BROWN	C			X	YES	SALEABLE
33471-0319	GREEN	D			X	YES	SALEABLE
33471-0320							VOIDED
33471-0321	BLACK	A	X		X	-	SALEABLE
33471-0322	LT.GRAY	B	X		X	-	SALEABLE
33471-0323	BROWN	C	X		X	-	SALEABLE
33471-0324	GREEN	D	X		X	-	SALEABLE
33471-0325							VOIDED
33471-0326	BLACK	A	X		X	YES	SALEABLE
33471-0327	LT.GRAY	B	X		X	YES	SALEABLE
33471-0328	BROWN	C	X		X	YES	SALEABLE
33471-0329	GREEN	D	X		X	YES	SALEABLE
33471-0330							VOIDED
33471-0331	BLACK	A	X	X	X	-	SALEABLE
33471-0332	LT.GRAY	B	X	X	X	-	SALEABLE
33471-0333	BROWN	C	X	X	X	-	SALEABLE
33471-0334	GREEN	D	X	X	X	-	SALEABLE
33471-0335							VOIDED
33471-0336	BLACK	A		X		YES	SALEABLE
33471-0337	BLACK	A		X		-	SALEABLE
33471-0338	BLACK	A	X	X	X	YES	SALEABLE
33471-0339	BLACK	A	X			-	SALEABLE
33471-0340	DK.GRAY	C				YES	TOOLED BUT NOT VALIDATED
33471-0341	LT.GRAY	B		X		YES	SALEABLE
33471-0342	DK.GRAY	C		X		YES	TOOLED BUT NOT VALIDATED
33471-0343	DK.GRAY	C				-	TOOLED BUT NOT VALIDATED
33471-0344	ST.GRAY	D				-	TOOLED BUT NOT VALIDATED
33471-0345	DK.GRAY	C				YES	TOOLED BUT NOT VALIDATED
33471-0346	ST.GRAY	D				YES	TOOLED BUT NOT VALIDATED

\*FOR ASSEMBLY P/N'S 33471-0340 AND 33471-0342 REFER TO SALEABLE KEY OPTION C ASSEMBLY P/N'S ABOVE

<b>ENTER DESCRIPTION</b> IEC NO. UAU2013-0423 DRAWN/CUNNINGHAM 2012/09/11 CHKD: APPR:VKOSHY 2012/09/17	QUALITY SYMBOLS	GENERAL TOLERANCES (UNLESS SPECIFIED)	DIMENSION STYLE	SCALE	DESIGN UNITS	THIRD ANGLE PROJECTION
	▽=0	mm INCH	MM ONLY		METRIC	
	▽=0	4 PLACES ± --- ± ---	DRAWN BY DATE	TITLE		
	▽=0	3 PLACES ± --- ± ---	DMARCOUX 06/18/2002	MX150 1X3 RECEPTACLE SEALED ASSEMBLY MAT SEAL		
	2 PLACES ± 0.1 ± ---	CHECKED BY DATE	DATE			
	1 PLACE ± 0.30 ± ---	DGRIFITHS 6/18/2002	APPROVED BY DATE			
	0 PLACE ± ±	FHOLUB 06/18/2002	MATERIAL NO. DOCUMENT NO.			
			SEE BOM		SD-33471-031	SHEET NO. 4 OF 4
		ANGULAR ± 3 °	THIS DRAWING CONTAINS INFORMATION THAT IS PROPRIETARY TO MOLEX INCORPORATED AND SHOULD NOT BE USED WITHOUT WRITTEN PERMISSION			
		DRAFT WHERE APPLICABLE MUST REMAIN WITHIN DIMENSIONS				

TABLE OF CONTENTS	
SHEET NO.	SHEET DESCRIPTION
1	NOTES
2	KEY CONFIGURATIONS
3	BLADE SEALED ASSEMBLY
4	SYSTEM PACKAGING
5	BOM

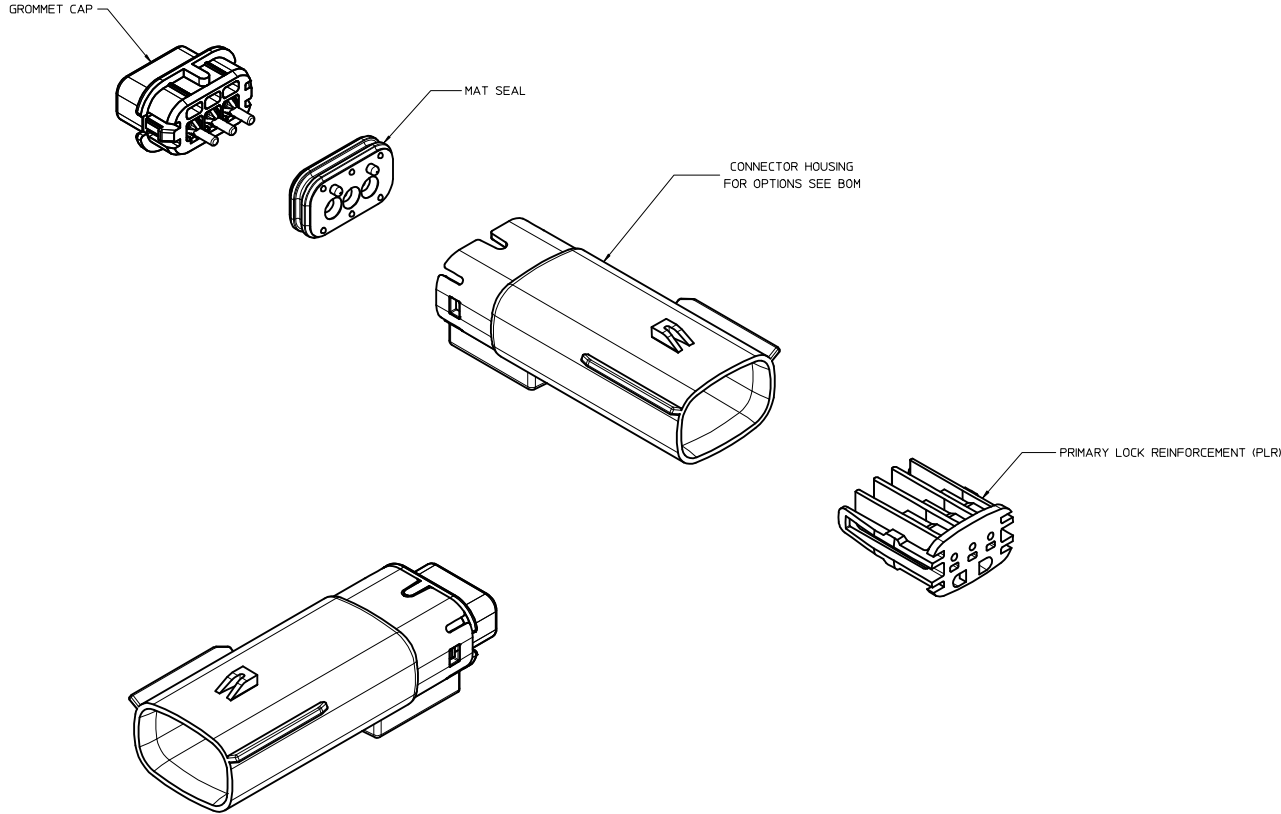

NOTES: VALID UNLESS OTHERWISE SPECIFIED

1. GENERAL:
  - a. APPLICATION SPECIFICATION SEE: AS-33472-100  
CONTAINS: PRODUCT INTRODUCTION, PRODUCT SUMMARY, CONNECTOR ASSEMBLY, PACKAGING INFORMATION, CONNECTOR MATING, SERVICE INSTRUCTIONS, ELECTRICAL CONTINUITY CHECKING, CRIMPING, AND TROUBLESHOOTING.  
-DESIGNED TO MATE WITH RECEPTACLE SEALED ASSEMBLY SPECIFIED IN MOLEX DRAWING SD-33471-031.  
-FOR 1.5mm BLADE TERMINALS TO BE USED WITH THIS ASSEMBLY SEE MOLEX DRAWING SD-33000-001.  
- SYSTEM TO BE USED WITH WIRE WITHIN DIAMETER RANGE OF 1.2mm TO 2.69mm.  
-ASSEMBLY SHIPPED WITH PLR IN PRE-LOCK POSITION  
-IN THE EVENT THAT THE PLR IS FOUND IN THE SEATED (FINAL LOCK) POSITION, REFER TO MOLEX SPECIFICATION PS-34646-001, AVAILABLE AT [www.molex.com](http://www.molex.com) <<http://www.molex.com>>  
-ASSEMBLY CONFORMS TO SAE/USCAR-2 REV.4 WITH THE FOLLOWING EXCEPTIONS:  
TERMINAL INSERTION FORCE FOR WIRE DIAMETER ABOVE 2.5mm NOT EXCEEDING 2.69mm SHALL NOT EXCEED 45 NEWTONS.
  - b. PRODUCT SPECIFICATION SEE: PS-33471-000  
CONTAINS: PRODUCT INTRODUCTION, PRODUCT SUMMARY, RATINGS (CURRENT, TEMPERATURE, SEALING, AND FLAMMABILITY), AND PRODUCT VALIDATION.
  - c. PACKAGING SPECIFICATION PER MOLEX DRAWING: PK-31300-635
  - d. PARTS MUST BE IN COMPLIANCE TO MOLEX CHEMICAL SUBSTANCES FOR PRODUCTS AND PACKAGING SPECIFICATIONS ES-40000-5016
  - e. DATA MUST BE SUBMITTED UNDER THE MOLEX PART NUMBER TO IMDS (COMPANY ID#13255)
2. DESIGN - MATERIALS:
  - a. CONNECTOR HOUSING, GROMMET CAP, PLR: SPS/NYLON BLEND 20% GLASS FILLED
  - b. MAT SEAL: INHERENTLY LUBRICATED SILICONE
3. DESIGN - GEOMETRY:
  - a. THIS IS A 100% CAD GENERATED PART. THE CAD MATHEMATICAL DATA IS THE MASTER FOR THIS PART. FOR DIMENSIONAL OR ANY INFORMATION NOT SHOWN ON THIS DRAWING, ANALYZE THE CAD MODEL.
  - b. GEOMETRIC DIMENSIONS AND TOLERANCES PER ASME Y14.5M - 1994
  - c. EDGES AND UNDIMENSIONED DETAILS PER ISO13715
  - d. CORNERS SHOWN AS SHARP TO BE R 0.2 MAX.
  - e. LETTERING SHALL BE 0.15 MAX RAISED IN 0.25 MAX RECESS PAD. THIS INCLUDES RECYCLING CODE, CAVITY ID, VENDOR IDENTIFICATION, AND CUSTOMER MATERIAL NUMBER.
  - f. VISUAL DEFECTS SHALL MEET COSMETIC STANDARD PS-45499-002 (Class B)
  - g. LASER MARKING: TBD

INSPECTION NUMBER LOG  
LAST NUMBER USED: 8  
ADDED:  
REMOVED:

N	UPDATED GROMMET CAP							
M3	UPDATED DIMENSIONS TO MATCH MODEL							
M2	COLOR REPLACEMENT FOR KEY C AND D PER USCAR STANDARD							
M1	UPDATED NOTES							
M	REDRAWN							
REV	DESCRIPTION							
	<table border="0"> <tr> <td>MM ONLY</td> <td>SCALE 3:1</td> <td>DESIGN UNITS METRIC</td> <td>THIRD ANGLE PROJECTION</td> </tr> </table>	MM ONLY	SCALE 3:1	DESIGN UNITS METRIC	THIRD ANGLE PROJECTION			
MM ONLY	SCALE 3:1	DESIGN UNITS METRIC	THIRD ANGLE PROJECTION					
	<table border="0"> <tr> <td>DRAWN BY DMARCOUX</td> <td>DATE 06-12-02</td> <td rowspan="3"> <b>MX150 1X3 BLADE SEALED ASSEMBLY MAT SEAL</b>  </td> </tr> <tr> <td>CHECKED BY DGRIFFIT</td> <td>DATE 06-12-02</td> </tr> <tr> <td>APPROVED BY FHOLUB</td> <td>DATE 06-12-02</td> </tr> </table>	DRAWN BY DMARCOUX	DATE 06-12-02	<b>MX150 1X3 BLADE SEALED ASSEMBLY MAT SEAL</b> 	CHECKED BY DGRIFFIT	DATE 06-12-02	APPROVED BY FHOLUB	DATE 06-12-02
DRAWN BY DMARCOUX	DATE 06-12-02	<b>MX150 1X3 BLADE SEALED ASSEMBLY MAT SEAL</b> 						
CHECKED BY DGRIFFIT	DATE 06-12-02							
APPROVED BY FHOLUB	DATE 06-12-02							
	<table border="0"> <tr> <td>MATERIAL NO. SEE BOM</td> <td>DOCUMENT NO. SD-33481-031</td> <td>SHEET NO. 1 OF 5</td> </tr> </table>	MATERIAL NO. SEE BOM	DOCUMENT NO. SD-33481-031	SHEET NO. 1 OF 5				
MATERIAL NO. SEE BOM	DOCUMENT NO. SD-33481-031	SHEET NO. 1 OF 5						

<b>SEE REV. COLUMN</b> IEC NO: UAU2013-1478 DRAWN: APPROFIT 2013/03/19 CHKD: HOICK 2013/03/20 APPR: IKOSHY 2013/03/20 REV DESCRIPTION	QUALITY SYMBOLS	GENERAL TOLERANCES (UNLESS SPECIFIED)	DIMENSION STYLE	SCALE	DESIGN UNITS	THIRD ANGLE PROJECTION	
	▽=0	mm INCH	MM ONLY	3:1	METRIC		
	▽=0	4 PLACES ± --- ± ---	DRAWN BY DATE				
	▽=0	3 PLACES ± --- ± ---	DMARCOUX 06-12-02				
	2 PLACES ± 0.10 ± ---	CHECKED BY DATE					
	1 PLACE ± 0.3 ± ---	DGRIFFIT 06-12-02					
	0 PLACE ± ±	APPROVED BY DATE					
		FHOLUB 06-12-02					
		ANGULAR ± 3 °					
		DRAFT WHERE APPLICABLE MUST REMAIN WITHIN DIMENSIONS					
			SIZE				
			D				

KEY CONFIGURATIONS

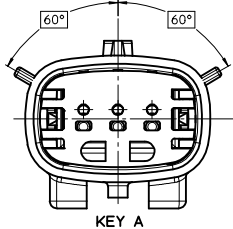

KEY A

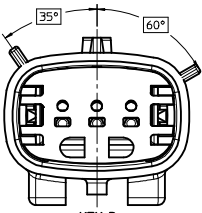

KEY B

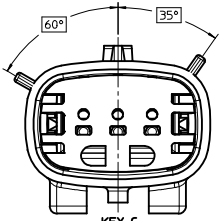

KEY C

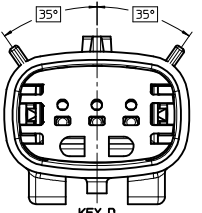

KEY D

SEE REV. COLUMN IEC NO. UAU2013-1478 DRAWN: PROFFITT 2013/03/20 CHECKED: DICK 2013/03/20 APPR: KOSHY 2013/03/20	QUALITY SYMBOLS ∇=0 ∇=0 ∇=0	GENERAL TOLERANCES (UNLESS SPECIFIED)		DIMENSION STYLE <b>MM ONLY</b>	SCALE <b>4:1</b>	DESIGN UNITS <b>METRIC</b>	THIRD ANGLE PROJECTION
		4 PLACES ± 0.10 3 PLACES ± 0.15 2 PLACES ± 0.20 1 PLACE ± 0.30 0 PLACE ± 0.50	mm    INCH	DRAWN BY DMARCOUX	DATE 06-12-02	TITLE <b>MX150 1X3 BLADE SEALED ASSEMBLY MAT SEAL</b>	
ANGLAR ± 3 ° DRAFT WHERE APPLICABLE MUST REMAIN WITHIN DIMENSIONS	MATERIAL NO. <b>SEE BOM</b>	APPROVED BY FHOLUB		DATE 06-12-02	DOCUMENT NO. <b>SD-33481-031</b>		
SIZE <b>D</b>	THIS DRAWING CONTAINS INFORMATION THAT IS PROPRIETARY TO MOLEX INCORPORATED AND SHOULD NOT BE USED WITHOUT WRITTEN PERMISSION						

LASER MARKING THIS SURFACE  
SEE NOTE 3g.

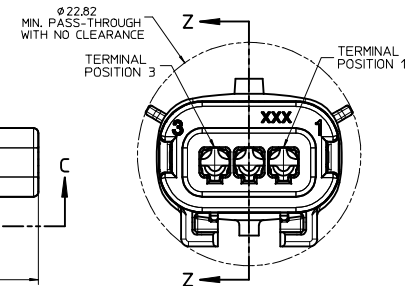
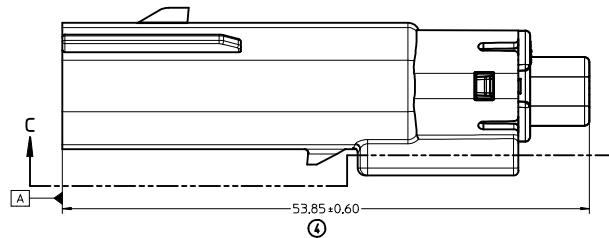
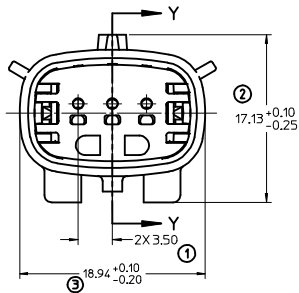
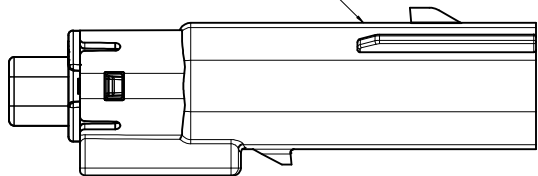

REAR VIEW  
(WIRE HARNESS SIDE)

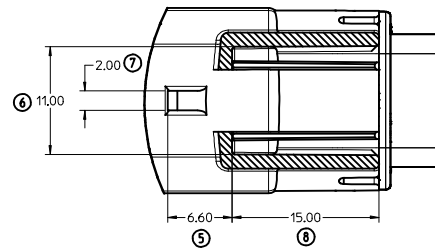
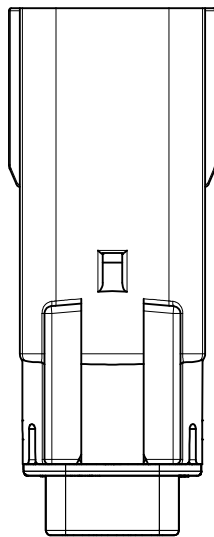

SECTION C-C

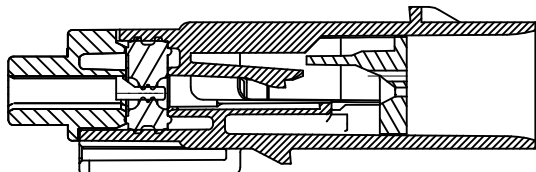

PRIMARY LOCK REINFORCEMENT (PLR) SHOWN  
IN PRE-STAGED POSITION

SECTION Z-Z

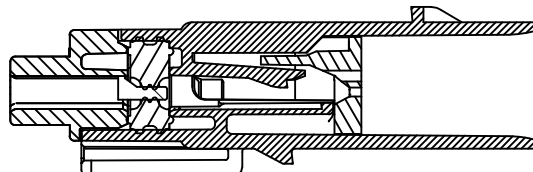

PRIMARY LOCK REINFORCEMENT (PLR) SHOWN  
IN FINAL-LOCK POSITION

SECTION Y-Y

SEE REV. COLUMN IEC NO. UAU2013-1478 DRAWN: PROFFITT CHYKHOLOK APPR: VIOSHY	2013/03/19 2013/03/20	QUALITY SYMBOLS ∇=0 ∇=0 ∇=0	GENERAL TOLERANCES (UNLESS SPECIFIED) mm INCH 4 PLACES ± --- ± --- 3 PLACES ± 0.10 ± --- 2 PLACES ± 0.3 ± --- 1 PLACE ± ± --- 0 PLACE ± ± ---	DIMENSION STYLE MM ONLY	SCALE 4:1	DESIGN UNITS METRIC	THIRD ANGLE PROJECTION	
	DRAWN BY DMARCOUX	DATE 06-12-02	CHECKED BY DGRIFFIT	DATE 06-12-02	APPROVED BY FHOLUB	DATE 06-12-02	MATERIAL NO. SEE BOM	DOCUMENT NO. SD-33481-031
	ANGULAR ± 3 ° DRAFT WHERE APPLICABLE MUST REMAIN WITHIN DIMENSIONS	SIZE D	THIS DRAWING CONTAINS INFORMATION THAT IS PROPRIETARY TO MOLEX INCORPORATED AND SHOULD NOT BE USED WITHOUT WRITTEN PERMISSION					
	SHEET NO. 3 OF 5							

20 19 18 17 16 15 14 13 12 11 10 9 8 7 6 5 4 3 2 1

SYSTEM PACKAGING

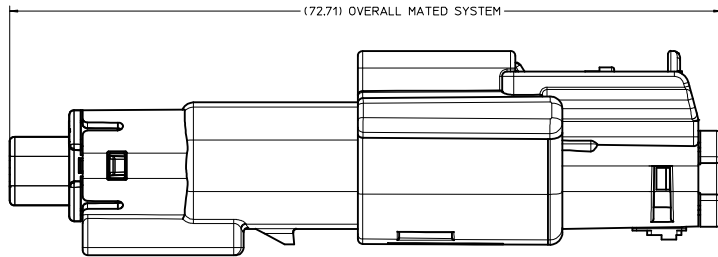

∅25.30  
MIN. PASS-THROUGH  
WITH NO CLEARANCE

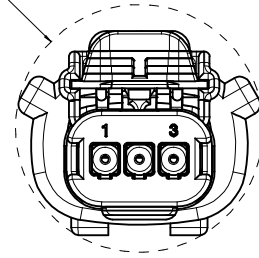

SEE REV. COLUMN IEC NO. UAU2013-1478 DRAWN/PROFFITT 2013/03/19 CHYKHODICK 2013/03/20 APPR:VKOSHY 2013/03/20	QUALITY SYMBOLS	GENERAL TOLERANCES (UNLESS SPECIFIED)	DIMENSION STYLE	SCALE	DESIGN UNITS	THIRD ANGLE PROJECTION
	∇=0 ∇=0 ∇=0	4 PLACES ± mm ± INCH 3 PLACES ± --- ± --- 2 PLACES ± 0.10 ± --- 1 PLACE ± 0.3 ± --- 0 PLACE ± ±	MM ONLY	4:1	METRIC	DRAWN BY DATE DMARCOUX 06-12-02 CHECKED BY DATE DGRIFFIT 06-12-02 APPROVED BY DATE FHOLUB 06-12-02
ANGULAR ± 3 ° DRAFT WHERE APPLICABLE MUST REMAIN WITHIN DIMENSIONS	MATERIAL NO. SEE BOM	TITLE MX150 1X3 BLADE SEALED ASSEMBLY MAT SEAL	DOCUMENT NO. SD-33481-031	SHEET NO. 4 OF 5		
THIS DRAWING CONTAINS INFORMATION THAT IS PROPRIETARY TO MOLEX INCORPORATED AND SHOULD NOT BE USED WITHOUT WRITTEN PERMISSION						

19 18 17 16 15 14 13 12 11 10 9 8 7 6 5 4 3 2 1



ASSEMBLY PART NUMBER	COLOR	KEYING OPTION	CAVITY TYPE & STATUS (X = PLUGGED)			COMMENTS
			1	2	3	
33481-0301	BLACK	A				
33481-0302	LT. GRAY	B				
33481-0303	BROWN	C				NOT RECOMMENDED, SEE P/N 33481-0322
33481-0304	GREEN	D				NOT RECOMMENDED, SEE P/N 33481-0323
33481-0305	CUSTOM	TBD				
33481-0306	BLACK	A			X	
33481-0307	LT. GRAY	B			X	
33481-0308	BROWN	C			X	
33481-0309	GREEN	D			X	
33481-0310	CUSTOM	TBD			X	
33481-0311	BLACK	A	X		X	
33481-0312	LT. GRAY	B	X		X	
33481-0313	BROWN	C	X		X	
33481-0314	GREEN	D	X		X	
33481-0315	CUSTOM	TBD	X		X	
33481-0316	BLACK	A	X	X	X	
33481-0317	LT. GRAY	B	X	X	X	
33481-0318	BROWN	C	X	X	X	NOT RECOMMENDED, SEE P/N 33481-0324
33481-0319	GREEN	D	X	X	X	NOT RECOMMENDED, SEE P/N 33481-0325
33481-0320	CUSTOM	TBD	X	X	X	
33481-0321	BLACK	A		X		
33481-0322	DK. GRAY	C				
33481-0323	ST. GRAY	D				
33481-0324	DK. GRAY	C	X	X	X	
33481-0325	ST. GRAY	D	X	X	X	

<b>SEE REV. COLUMN</b> IEC NO. UAU2013-1478 DRAWN: APPROFIT 2013/03/20 CHECKED: MOJCK 2013/03/20 APPR: WJOSHY 2013/03/20	QUALITY SYMBOLS	GENERAL TOLERANCES (UNLESS SPECIFIED)	DIMENSION STYLE	SCALE	DESIGN UNITS	THIRD ANGLE PROJECTION
	▽=0	mm INCH	MM ONLY		METRIC	
	▽=0	4 PLACES ± 0.10	DRAWN BY DATE			MX150 1X3 BLADE SEALED ASSEMBLY MAT SEAL 
	▽=0	3 PLACES ± 0.03	DMARCOUX 06-12-02			
	2 PLACES ± 0.10	CHECKED BY DATE				
	1 PLACE ± 0.3	DGRIFFIT 06-12-02				
	0 PLACE ±	APPROVED BY DATE				
		FHOLUB 06-12-02				
		MATERIAL NO.	SEE BOM			
		DOCUMENT NO.	SD-33481-031			
		SHEET NO.	5 OF 5			
		THIS DRAWING CONTAINS INFORMATION THAT IS PROPRIETARY TO MOLEX INCORPORATED AND SHOULD NOT BE USED WITHOUT WRITTEN PERMISSION				