

**iPass+™  
HSC  
Stack Dual-Port  
Press-In Tool**

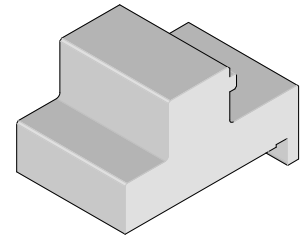

**Application Tooling  
Specification Sheet**



**Order No. 62203-0420**

**FEATURES**

- Lip provided for positive alignment to connector assembly
- Inserts connector to a PCB without damage to the board
- Use tool 62203-0430 for extracting connectors

**SCOPE**

Products: iPass+™ HSC Stack Dual-Port Integrated Cage and Connector Assembly, 168 Circuit, Press-Fit. See Product List below for specific part numbers.

**Product List**

The following is a partial list of the product order numbers and their specifications this tool is designed to run. Updates to this list are available on [www.molex.com](http://www.molex.com).

Connector Series No.	Assembly Order No.	
76024	76024-0568	76024-0569

**Notes:**

1. See the following pages for tooling operation instructions.
2. These tools require a “Keep Out Zone” around the connector free of components. See Figure 1.

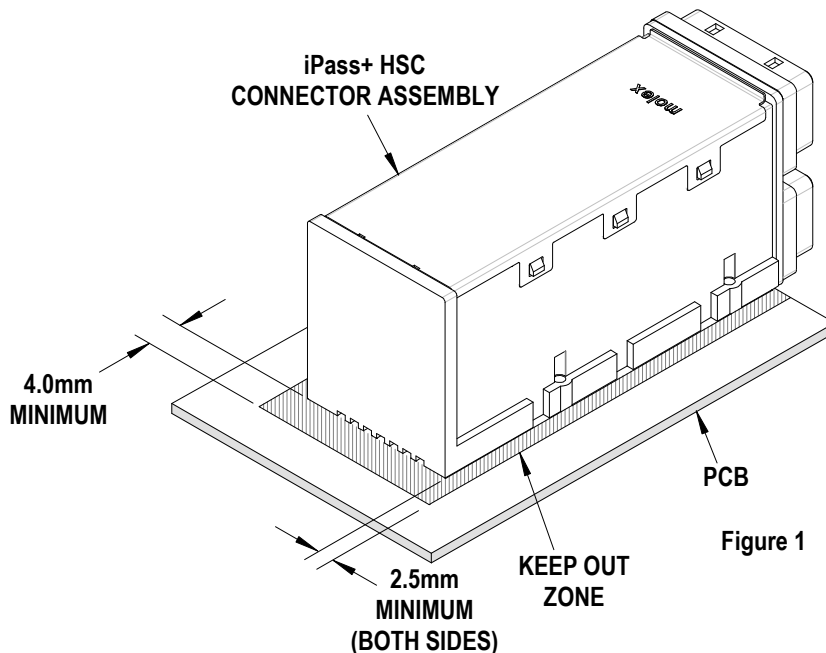

Figure 1

## Tool Setup

Depending on the number of connectors to be installed and/or the press used, this tool can be used alone or with a group of press-in tools, mounted in a 62201-95XX rail (ordered separately). See Figure 2.

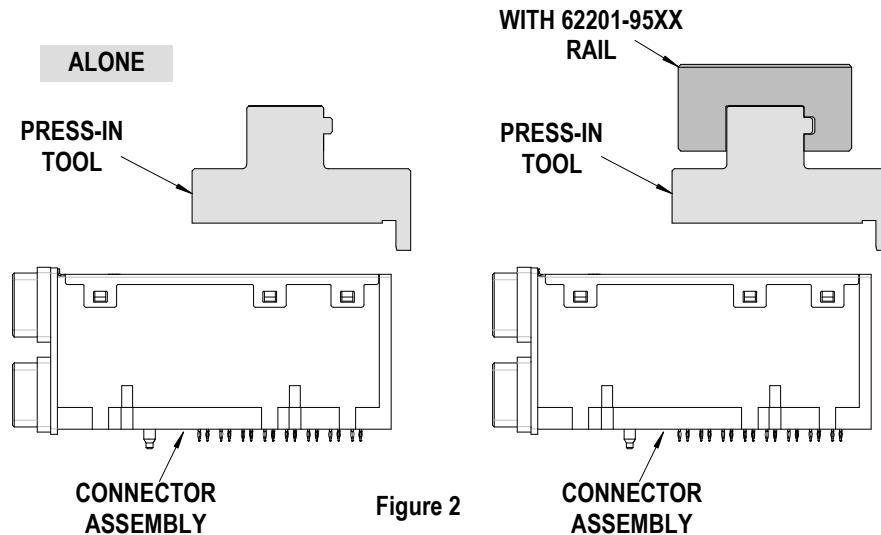

Figure 2

## Tool Installation

The 62201-95XX rail is available in a variety of lengths to accommodate multiple press-in tools.

Rail Order Number	Rail Overall Length
62201-9501	24mm (0.94 in)
62201-9502	72mm (2.83 in)
62201-9503	156mm (6.14 in)
62201-9504	216mm (8.50 in)
62201-9509	254mm (10.0 in)
62201-9511	305mm (12.0 in)

Reference: This Press-In Tool is 25.0mm (0.98 in.) long.

## Printed Circuit Board (PCB) Support

The iPass+™ connector assembly requires significant force to press into the PCB. To prevent excessive PCB flexure and/or damage to the PCB, a support plate is strongly recommended directly beneath the connector hole pattern.

Due to the custom nature of every application, Molex does not offer any PCB support plate. The customer must furnish their own support plate.

When creating the PCB support plate, remember to allow clearance for the connector pins if they pass through the PCB thickness.

## Tool Operation

1. Carefully insert, by hand, the connector assembly using the alignment pegs from the cover for the location on the PCB. The number of alignment pegs will increase with larger cage assemblies.

2. Place the press-in-tool on top of the connector assembly with the back guide surface of the tool against the back of the connector assembly.
3. Place tool, connector, and PCB in a press of suitable size and force, and seat the connector assembly as shown. The support plate (furnished by the customer) under the PCB must have clearance for the connector pins.
4. Add required number of M2 x 8 BHCS to secure the iPass+™ assembly to the PCB. (See module product sales drawings for correct mounting screw length).

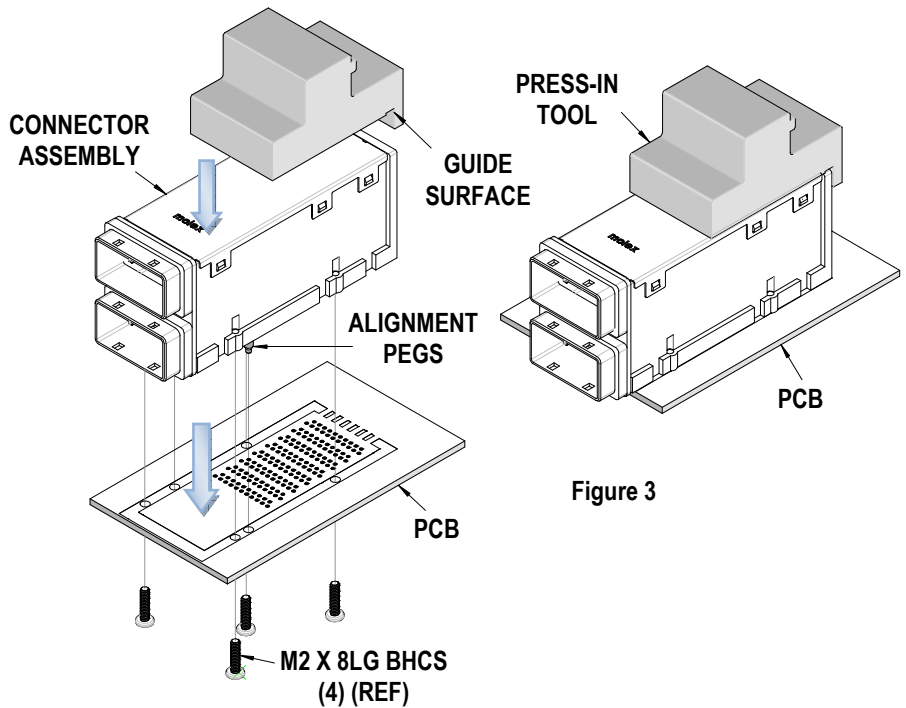

Figure 3

iPass+™ Assembly	Molex Product Sales Drawing
76024	SD-76024-568

**CAUTION:** To prevent injury, never operate any press without the guards in place. Refer to the press manufacturer's instruction manual.

**CAUTION:** Molex application tooling specifications are valid only when used with Molex connectors and tooling.

### Contact Information

For more information on Molex application tooling please contact Molex at 1-800-786-6539.

<http://www.molex.com>