

13 12 11 10 9 8 7 6 5 4 3 2 1

J
I
H
G
F
E
D
C
B
A

J
I
H
G
F
E
D
C
B
A

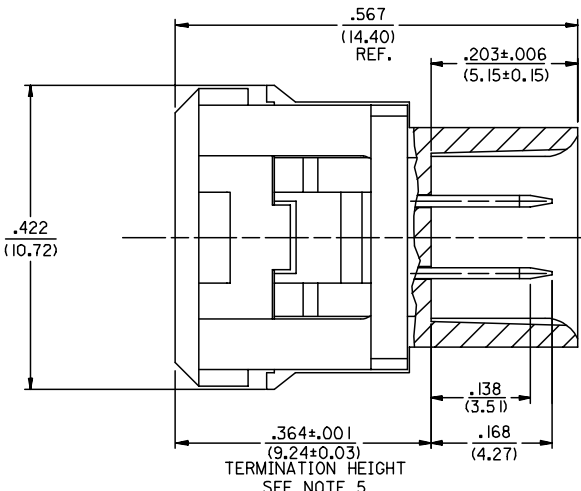
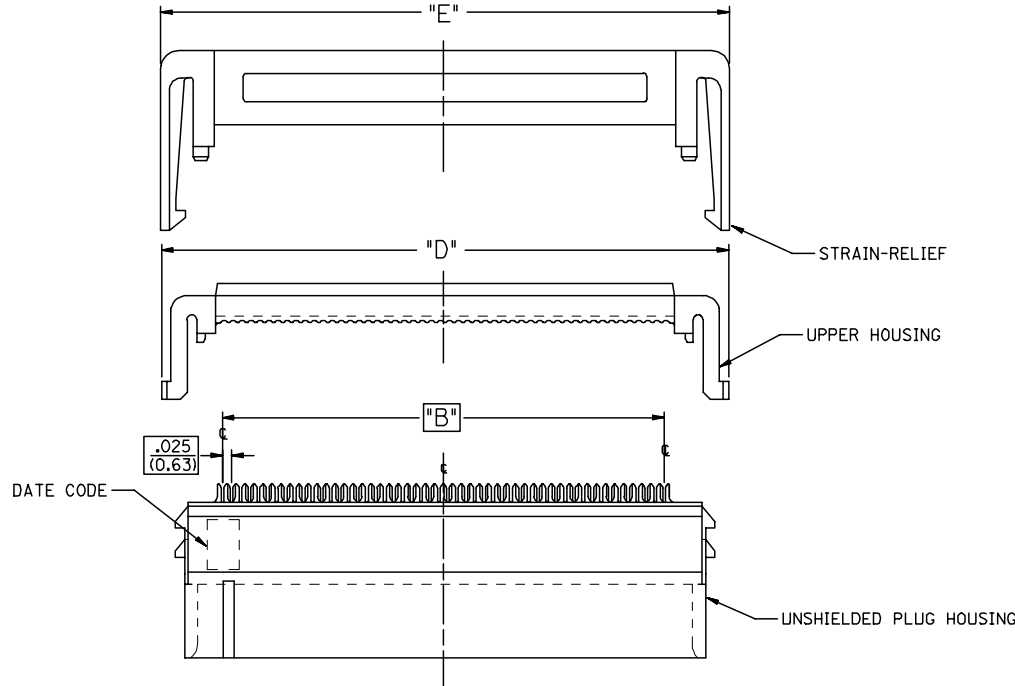

DETAIL "A"
(ASSEMBLED WITHOUT STRAIN-RELIEF)
SCALE 8:1

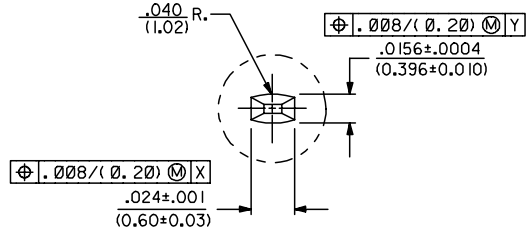
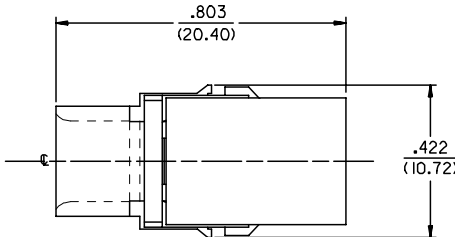
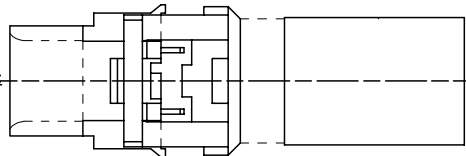
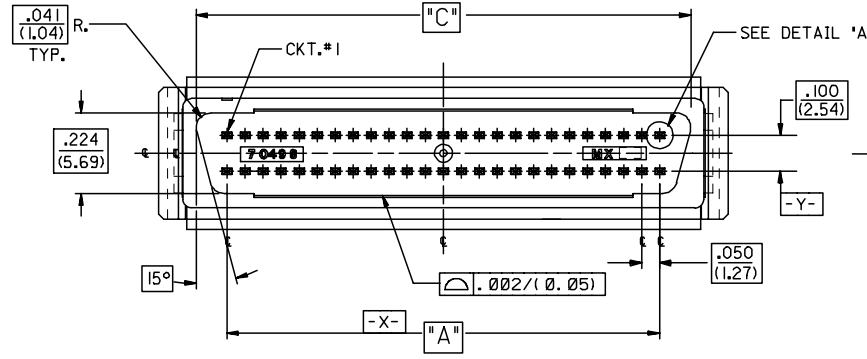

DETAIL A
SCALE = 20:1

50 CIRCUIT SHOWN

REMOVE OBSOLETE #'S EC NO: UCP2006-2901 DRAWN BY: BARRA 2006/06/12 CHKD: BARKER 2006/06/12 APPR: MILLER 2006/06/14	QUALITY SYMBOLS ▽=0 ▽=0	GENERAL TOLERANCES (UNLESS SPECIFIED)		DIMENSION STYLE IN/MM		SCALE 4:1	DESIGN UNITS INCH	THIRD ANGLE PROJECTION			
		4 PLACES ± --- ± ---	3 PLACES ± --- ± .005	DRAWN BY JOLNG	DATE 1995/11/08	TITLE SCSI ALL-PLASTIC MODULAR SUB-ASSEMBLY KIT FOR .025 RIBBON CABLE					
		2 PLACES ± 0.13 ± ---	1 PLACE ± --- ± ---	CHECKED BY JLONG	DATE 1995/11/08	APPROVED BY DCB					
		ANGULAR ±1/2°		MATERIAL NO. SEE TABLE		DOCUMENT NO. SDMS-70498-5***		SHEET NO. 1 OF 3			

3	D
2	F
1	F
	SHT REV

12 11 10 9 8 7 6 5 4 3 2 1

ITEM NO.	CKT. SIZE	PLATING TYPE	ITEM	DESCRIPTION/ITEM NO.	QTY	"A"		"B"		"C"		"D"		"E"	
						IN.	MM.	IN.	MM.	IN.	MM.	IN.	MM.	IN.	MM.
NA	50	GOLD 30	A	PLUG ASSEMBLY : 70498-2050	1	1.200	30.48	1.225	31.12	1.372	34.85	1.577	40.06	1.580	40.13
			B	UPPER HOUSING : 70497-1050	1										
			C	STRAIN-RELIEF : 70499-3050	1										
70498-5068	68	GOLD 30	A	PLUG ASSEMBLY : 70498-2068	1	1.650	41.91	1.675	42.54	1.822	46.28	2.027	51.49	2.030	51.56
			B	UPPER HOUSING : 70497-1068	1										
			C	STRAIN-RELIEF : 70499-3068	1										
70498-5101	68	GOLD 15	A	PLUG ASSEMBLY : 70498-2168	1	1.650	41.91	1.675	42.54	1.822	46.28	2.027	51.49	2.030	51.56
			B	UPPER HOUSING : 70497-1068	1										
			C	STRAIN-RELIEF : 70499-3068	1										
NA	68	GOLD 15	A	PLUG ASSEMBLY : 70498-2168	1	1.650	41.91	1.675	42.54	1.822	46.28	2.027	51.49	2.030	51.56
			B	UPPER HOUSING : 70497-1068	1										
			C	STRAIN-RELIEF : 70499-3068	1										

NOTES:

- REFER TO PS-79058 PRODUCT SPEC FOR ELECTRICAL, MECHANICAL AND ENVIRONMENTAL SPECIFICATIONS.
- MATERIAL:**
 PLUG HOUSING: POLYESTER (PBT), GLASS FILLES, UL94 V-0, COLOR: BLACK
 CONTACT: PHOSPHOR BRONZE
 UPPER HOUSING: POLYESTER (PBT), GLASS FILLES, UL94 V-0, COLOR: BLACK
 STRAIN RELIEF: POLYESTER (PBT), GLASS FILLES, UL94 V-0, COLOR: BLACK

FINISHES: TERMINALS:

(GOLD 15)
 SELECTIVE GOLD: THICKNESS= 15 MICROINCHES/(0.38 MICROMETERS) MINIMUM.
 SELECTIVE TIN: THICKNESS= 75 MICROINCHES/(1.90 MICROMETERS) MINIMUM.
 NICKEL UNDERPLATE OVERALL.

(GOLD 30)
 SELECTIVE GOLD: THICKNESS= 30 MICROINCHES/(0.76 MICROMETERS) MINIMUM.
 SELECTIVE TIN: THICKNESS= 75 MICROINCHES/(1.90 MICROMETERS) MINIMUM.
 NICKEL UNDERPLATE OVERALL.

- PACKAGING: SUBASSEMBLY SUPPLIED IN TUBES AND UPPER HSG. AND STRAIN-RELIEF SUPPLIED IN BULK PER PK-70873-0258.
- RECOMMENDED CABLE: 30 AWG STRANDED OR SOLID, .025 RIBBON. CONTACT MOLEX INC. FOR LIST OF APPROVED CABLES.
- APPLICATION TOOL CLOSURE OVER ASSY TO BE CONTROLLED TO .364±.001 USING A POSITIVE STOP TO ASSURE PROPER TERMINATION.
- STRAIN-RELIEF MAY BE POSITIONED SO THE TIE-BAR ORIENTATION CAN BE ON EITHER SIDE IN RELATIONSHIP TO THE CONNECTOR "D" SHAPE. IF THE STRAIN-RELIEF WILL BE USED ON A CABLE HARNESS AT AN END TERMINATION THE ORIENTATION SHOULD BE AS SHOWN. THE TIE-BAR SHOULD BE ON THE OPPOSITE SIDE OF THE CONNECTOR FROM THE CABLE FOLD.

NOTE FOR LEAD FREE CONVERSION:

THE PRIMARY SHIPPING CARTON WILL BE LABELED "COMPLIANT TO RoHS DIRECTIVE 2002/95/EC AND ELV ANNEX II OF DIRECTIVE 2000/53/EC". CARTONS WITHOUT THIS LABEL MAY CONTAIN PRODUCT WITH LEAD.

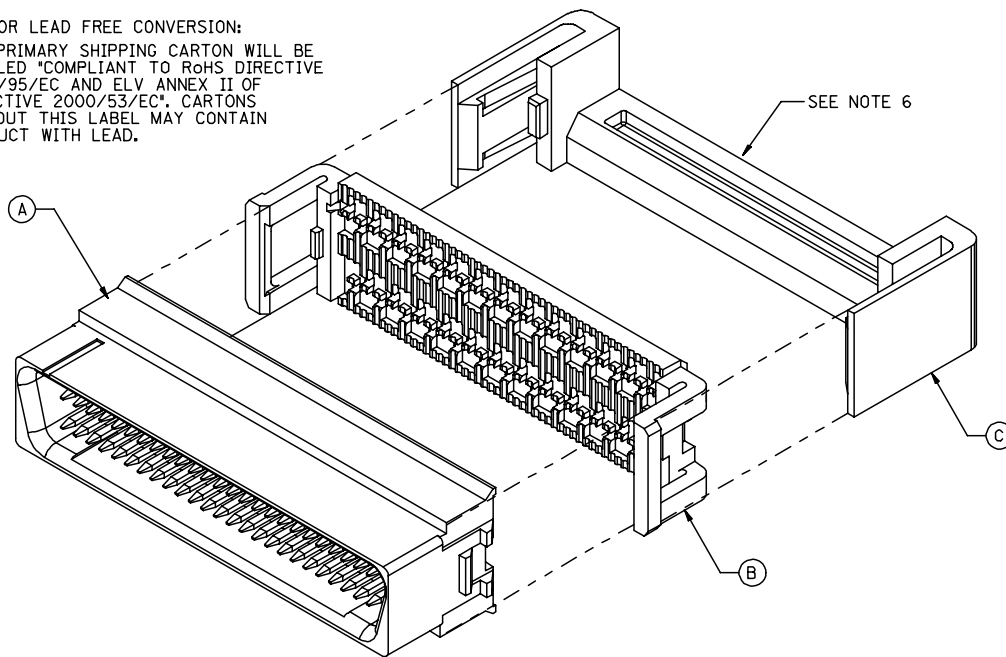

SEE NOTE 6

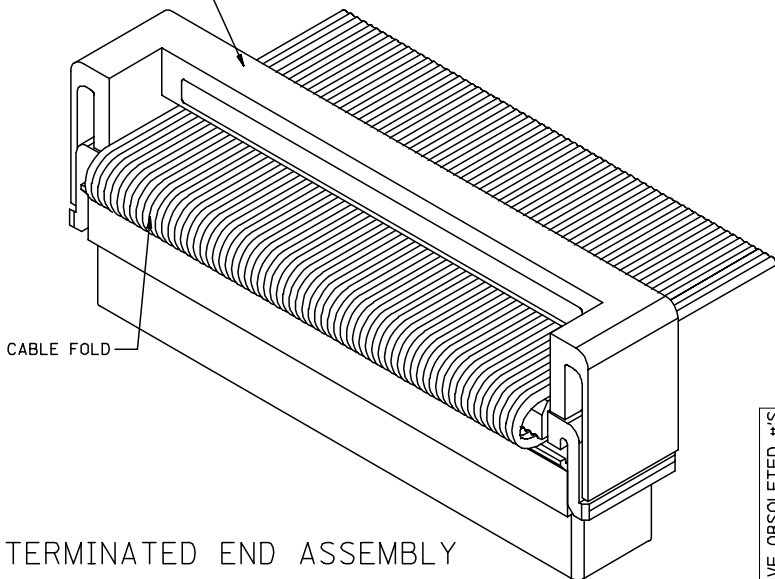

TERMINATED END ASSEMBLY
 FOR REFERENCE ONLY

DETAIL FOR PK-70873-0258
 FOR TUBE/BULK PACKAGING
 ITEM SERIES 70498-50** & -51**

50 CIRCUIT ASSEMBLY

REMOVE OBSOLETE #S EC NO: UCP2006-2901 DRWN:MS/BARRA 2006/06/12 CHKD:BBARKER 2006/06/12 APPR:SMILLER 2006/06/14 REVISION DESCRIPTION	QUALITY SYMBOLS	GENERAL TOLERANCES (UNLESS SPECIFIED)	DIMENSION STYLE	SCALE	DESIGN UNITS	THIRD ANGLE PROJECTION	
	$\nabla=0$ $\nabla=0$	mm INCH	IN/MM	4:1	INCH		
		4 PLACES ± --- ± ---	DRAWN BY	DATE	TITLE	SCSI ALL-PLASTIC MODULAR SUB-ASSEMBLY KIT FOR .025 RIBBON CABLE	
		3 PLACES ± --- ± ---	JLONC	1995/11/08		MOLEX INCORPORATED	
	2 PLACES ± --- ± ---	2 PLACES ± --- ± ---	CHECKED BY	DATE			
	1 PLACE ± --- ± ---	1 PLACE ± --- ± ---	JLONC	1995/11/08			
		ANGULAR ±1/2°	APPROVED BY	DATE			
			DCB	1995/11/08			
			MATERIAL NO.	DOCUMENT NO.	SHEET NO.		
			SEE TABLE	SDMS-70498-5***	2 OF 3		
		DRAFT WHERE APPLICABLE MUST REMAIN WITHIN DIMENSIONS	THIS DRAWING CONTAINS INFORMATION THAT IS PROPRIETARY TO MOLEX INCORPORATED AND SHOULD NOT BE USED WITHOUT WRITTEN PERMISSION				