

DO NOT SCALE FROM THIS PRINT

DESIGNED & DIMENSIONED IN MILLIMETERS[INCHES]

JSO-XXXX-XX-X

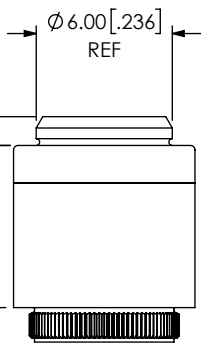
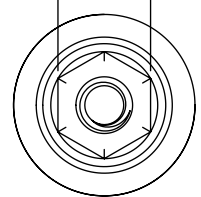
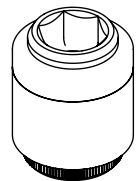
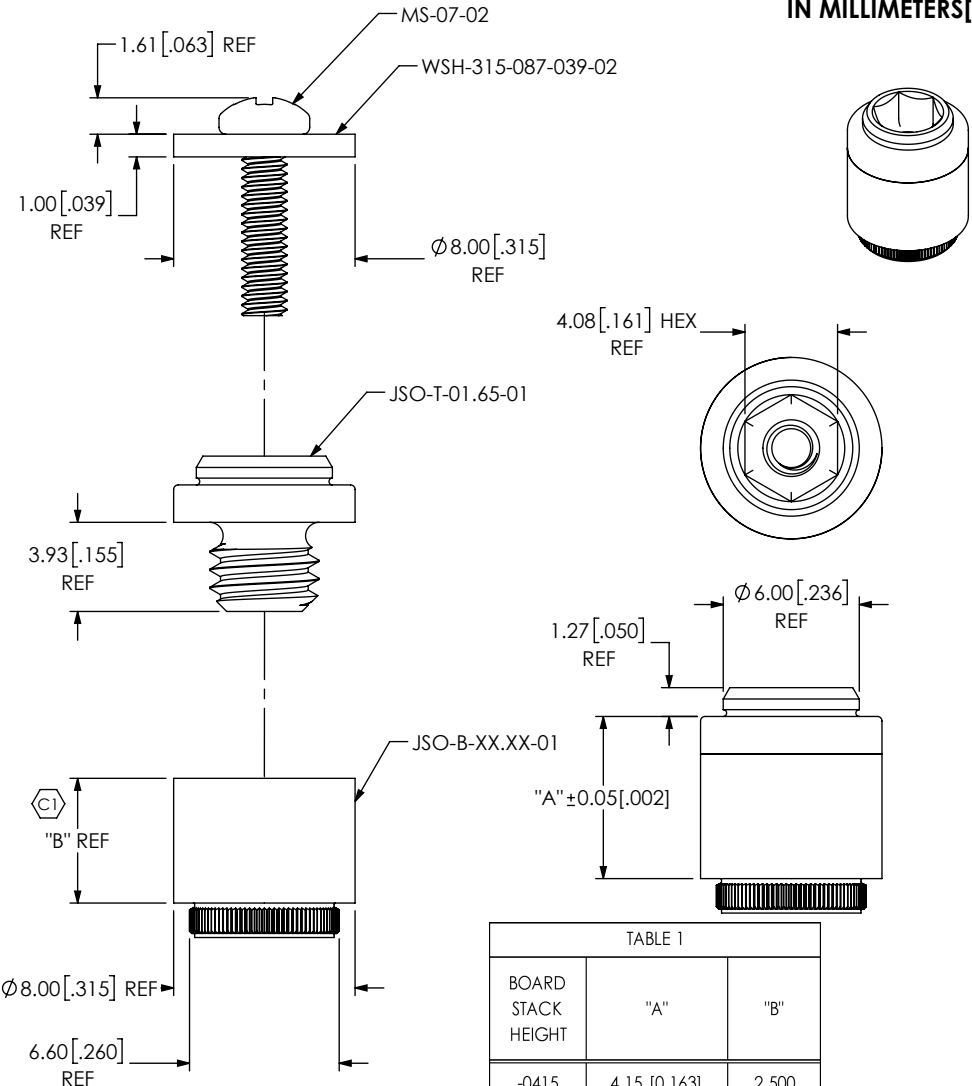

BOARD STACK HEIGHT
 -0415,-0515,-0715,-0815,
 -1015,-1115,-1215,
 -1615,-1765, *-3500

LEAD STYLE
 -01: PRESS-IN
 (FOR STACK HEIGHTS -0415,-0515,
 -0700, -0715,-0815,-1215,-1765 ONLY)

-03: THREADED
 (FOR STACK HEIGHTS -0815,-1015,
 -1115,-1215,-1615,*-3500 ONLY)
 (SEE SHT 2, FIG 2)
 *=NOT TOOLED

LOCKING OPTION
 -L: LOCKING COMPOUND
 (NOT AVAILABLE WITH -01
 LEAD STYLE, REQUIRED FOR
 -03 LEAD STYLE)

RECOMMENDED BOARD CUTOUT (-01: PRESS-IN AND JACK SCREW)

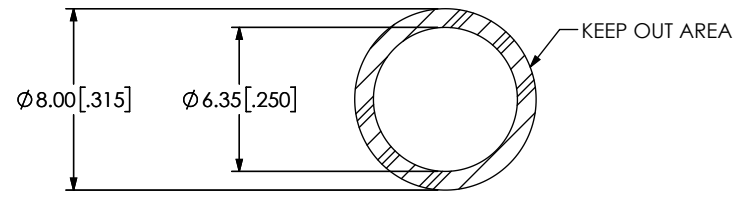

FIG 1 JSO-XXXX-01 SHOWN

TABLE 1

BOARD STACK HEIGHT	"A"	"B"
-0415	4.15 [0.163]	2.500
-0515	5.15 [0.203]	3.500
-0700	7.00 [0.276]	5.350
-0715	7.15 [0.281]	5.500
-0815	8.15 [0.321]	6.500
-1015	10.15 [0.400]	8.500
-1115	11.15 [0.439]	9.500
-1215	12.15 [0.478]	10.500
-1615	16.15 [0.636]	14.500
-1765	17.65 [0.695]	16.000
*-3500	35.00 [1.378]	33.350

*=NOT TOOLED

† TABLE 2 - BOM

FINISHED GOOD	STAND-OFF BASE	JACK SCREW	SCREW	NUT	WASHER
JSO-0415-01	JSO-B-02.50-01	JSO-T-01.65-01	MS-07-02	N/A	WSH-315-087-039-02
JSO-0515-01	JSO-B-03.50-01	JSO-T-01.65-01	MS-07-02	N/A	WSH-315-087-039-02
JSO-0700-01	JSO-B-05.35-01	JSO-T-01.65-01	MS-07-02	N/A	WSH-315-087-039-02
JSO-0715-01	JSO-B-05.50-01	JSO-T-01.65-01	MS-07-02	N/A	WSH-315-087-039-02
JSO-0815-01	JSO-B-06.50-01	JSO-T-01.65-01	MS-07-02	N/A	WSH-315-087-039-02
JSO-0815-03-L	JSO-B-06.50-03-L	JSO-T-01.65-01	MS-07-02	SN-03-02	WSH-315-087-039-02
JSO-1015-03-L	JSO-B-08.50-03-L	JSO-T-01.65-01	MS-07-02	SN-03-02	WSH-315-087-039-02
JSO-1115-03-L	JSO-B-09.50-03-L	JSO-T-01.65-01	MS-07-02	SN-03-02	WSH-315-087-039-02
JSO-1215-01	JSO-B-10.50-01	JSO-T-01.65-01	MS-07-02	N/A	WSH-315-087-039-02
JSO-1215-03-L	JSO-B-10.50-03-L	JSO-T-01.65-01	MS-07-02	SN-03-02	WSH-315-087-039-02
JSO-1615-03-L	JSO-B-14.50-03-L	JSO-T-01.65-01	MS-07-02	SN-03-02	WSH-315-087-039-02
JSO-1765-01	JSO-B-16.00-01	JSO-T-01.65-01	MS-07-02	N/A	WSH-315-087-039-02
*JSO-3500-03-L	*JSO-B-33.35-03-L	JSO-T-01.65-01	MS-07-02	SN-03-02	WSH-315-087-039-02

(*=NOT TOOLED)

† QTY = 1 FOR ALL COMPONENTS

PATENT PENDING

- NOTES:
- Ⓢ REPRESENTS CRITICAL DIMENSION
 - STANDOFFS TO BE USED WITH 1.57[.062]MIN THICK BOARDS.
 - COMPONENTS ARE TO BE BULK PACKAGED IN SEPARATE BAGS AND SHOULD NOT LIST INDIVIDUAL COMPONENT QUANTITY ON THE LABEL. ALL COMPONENT BAGS ARE TO BE PACKAGED IN A LARGER BAG WITH THE FINAL PART NUMBER QUANTITY OF ASSEMBLIES ON THE LABEL.
 - STANDOFFS ARE DESIGNED 0.15MM LONGER THAN CONNECTOR STACK HEIGHTS TO ALLOW FOR PROCESSING VARIABLES.
 - TORQUE TO 2.5 – 3.5 IN*LB'S TO SECURE FASTENER IN A STATIC ENVIRONMENT ASSUMING RECOMMENDED BOARD TO BOARD DISTANCES ARE ACHIEVED WITHOUT DAMAGE TO THE PCB, HARDWARE OR OTHER COMPONENTS.

UNLESS OTHERWISE SPECIFIED, DIMENSIONS ARE IN MILLIMETERS. TOLERANCES ARE:

DECIMALS ANGLES
 X.X: ±0.3 [.01]
 X.XX: ±0.13 [.005]
 X.XXX: ±0.051 [.0020]

MATERIAL: DO NOT SCALE DRAWING SHEET SCALE: 3:1
 STAINLESS STEEL
 LOCKING COMPOUND

PROPRIETARY NOTE
 THIS DOCUMENT CONTAINS CONFIDENTIAL AND PROPRIETARY INFORMATION AND ALL DESIGN, MANUFACTURING, REPRODUCTION, USE, PATENT RIGHTS AND SALES RIGHTS ARE EXPRESSLY RESERVED BY SAMTEC, INC. THIS DOCUMENT SHALL NOT BE DISCLOSED, IN WHOLE OR PART, TO ANY UNAUTHORIZED PERSON OR ENTITY NOR REPRODUCED, TRANSFERRED OR INCORPORATED IN ANY OTHER PRODUCT IN ANY MANNER WITHOUT THE EXPRESS WRITTEN CONSENT OF SAMTEC, INC.

c:\enterprise\vaulf\DWG\MISC\MKTG\JSO-XXXX-XX-X-MKT.SLDDRW

samtec

520 PARK EAST BLVD, NEW ALBANY, IN 47150
 PHONE: 812-944-6733 FAX: 812-948-5047
 e-Mail info@SAMTEC.com code 53322

DESCRIPTION:
 JACK SCREW STAND-OFF

DWG. NO.
 JSO-XXXX-XX-X

BY: KYLE B 2/4/2014 SHEET 1 OF 2

CRITICAL DIMENSION INSPECTION INSTRUCTION TABLE	
ASSEMBLY OPERATION	IN-PROCESS INSPECTION
RECEIVE	C1

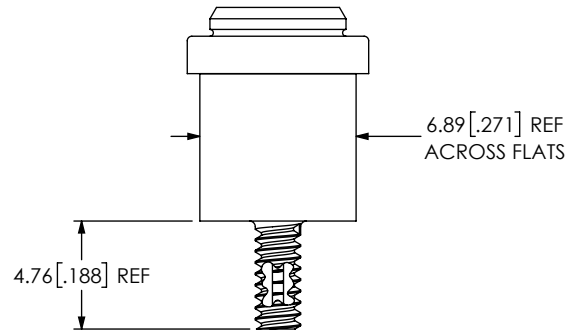
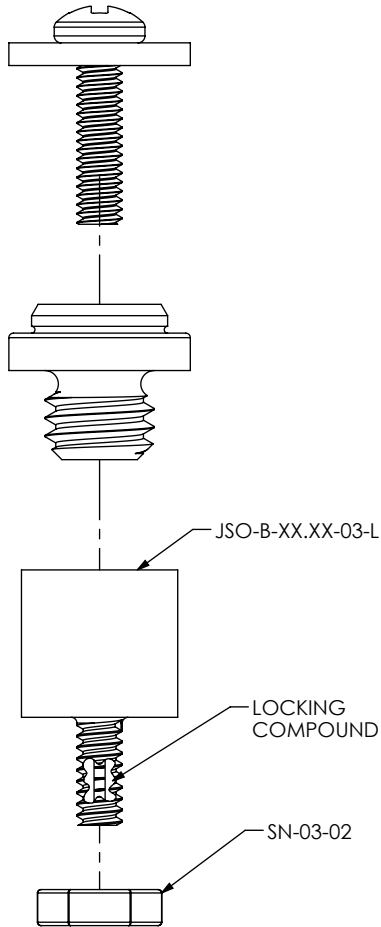
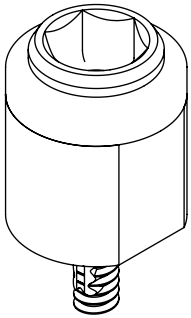

RECOMMENDED BOARD CUTOUT
(-03: THREADED)

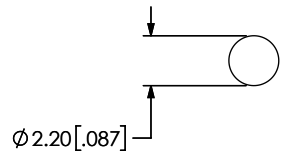

FIG 2
JSO-XXXX-03-L
(SAME AS FIG 1, EXCEPT AS SHOWN)

PROPRIETARY NOTE
THIS DOCUMENT CONTAINS CONFIDENTIAL AND PROPRIETARY INFORMATION AND ALL DESIGN, MANUFACTURING, REPRODUCTION, USE, PATENT RIGHTS AND SALES RIGHTS ARE EXPRESSLY RESERVED BY SAMTEC, INC. THIS DOCUMENT SHALL NOT BE DISCLOSED, IN WHOLE OR PART, TO ANY UNAUTHORIZED PERSON OR ENTITY NOR REPRODUCED, TRANSFERRED OR INCORPORATED IN ANY OTHER PROJECT IN ANY MANNER WITHOUT THE EXPRESS WRITTEN CONSENT OF SAMTEC, INC.

DO NOT SCALE DRAWING

SHEET SCALE: 3:1



520 PARK EAST BLVD, NEW ALBANY, IN 47150
PHONE: 812-944-6733 FAX: 812-948-5047
e-Mail info@SAMTEC.com code 55322

DESCRIPTION: JACK SCREW STAND-OFF

DWG. NO. JSO-XXXX-XX-X

BY: KYLE B 2/4/2014 SHEET 2 OF 2