

4

3

2

1

THIS DRAWING IS UNPUBLISHED. RELEASED FOR PUBLICATION ,19 .

© COPYRIGHT 19 BY AMP INCORPORATED. ALL RIGHTS RESERVED.

LOC	DIST	REVISIONS					
		P	LTR	DESCRIPTION	DATE	DWN	APVD
G	86		F	REV PER 0G3A-0637-01	030CT02	JR	MS

- ① TIN PLATE 0.00381 [0.000150] MIN THK PER ASTM B 545
- ② CLEANED, UNPLATED
- ③ PREPRODUCTION - FASR REQ

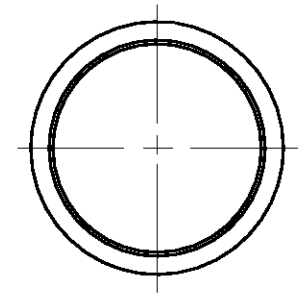
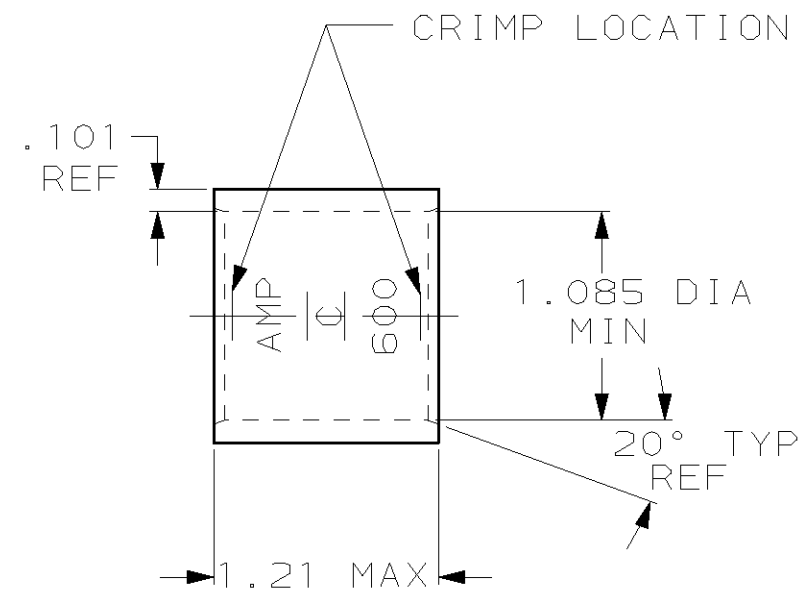

②-	③1-324452-0
①-	324452
FINISH	AMP PART NUMBER

THIS DRAWING IS A CONTROLLED DOCUMENT FOR AMP INCORPORATED. IT IS SUBJECT TO CHANGE AND THE CONTROLLING ENGINEERING ORGANIZATION SHOULD BE CONTACTED FOR THE LATEST REVISION.		DWN DK SCHRUM 01JUL96	AMP AMP Incorporated Harrisburg, PA 17105-3608
DIMENSIONS: mm [INCHES]		CHK WJ VOCKROTH 02JUL96	
TOLERANCES UNLESS OTHERWISE SPECIFIED:		APVD JL MECKLEY 02JUL96	NAME WIRE SPLICE, PARALLEL, AMPPOWER™
0 PLC ±-		PRODUCT SPEC -	WIRE SIZE: 600 MCM
1 PLC ±-		APPLICATION SPEC -	SIZE A3
2 PLC ±-		WEIGHT .146 lbs	CAGE CODE 00779
3 PLC ±-		CUSTOMER DRAWING	DRAWING NO C-324452
4 PLC ±-			SCALE 2:1
ANGLES ±-			SHEET 1 OF 1
MATERIAL COPPER PER ASTM B-75 ANNEALED	FINISH SEE TABLE		REV F